

CORFU RELAX SET

Instrukcja montażu | Assembly Instructions | Összeszerelési útmutató | Návod k montáži |
Návod na montáž | Navodila za uporabo | Руководство пользователя |
Інструкція з монтажу | Montavimo instrukcija | Uzstādīšanas instrukcija |
Kokkupanekujuhised | Istrucțiuni de montare | Upute za montažu | Uputstvo za montažu |
Инструкция на монтаж | Instruktion montimi

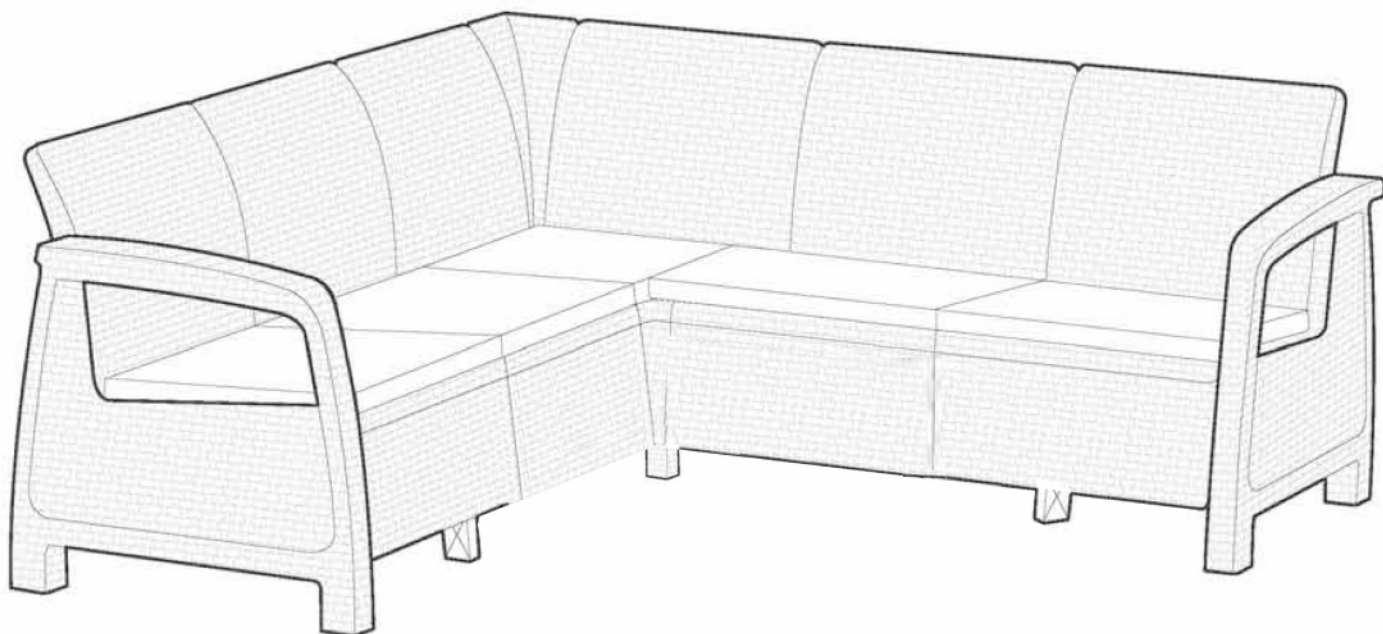

Ważne! Proponujemy zachować. | Important! Retain for future reference. |
Fontos! Ajánlott megőrizni. | Důležité! Doporučuje se uchovat. |
Dôležité! Odporúča sa uchovať. | Pomembno! Predlagamo shraniti. |
Внимание! Рекомендуется сохранить. | Увага! Рекомендується зберегти. |
Svarbu! Rekomenduojame išsaugoti. | Svarīgi! Ieteicām saglabāt. |
Oluline! Hoidke tuleviku tarbeks alles. | Important! Este recomandat să păstrați. |
Pažnja! Preporučujemo čuvati. | Pažnja! Preporučujemo da se čuva. |
Важно ! Предлагаме да се запази. | Me rëndësi! Ju propozojmë që të ruhet.

PL Uwagi i ostrzeżenia – należy przeczytać przed montażem.
EN Notes and warnings – please read carefully prior to assembly.
HU Megjegyzések és figyelmeztetések – összeszerelés előtt figyelmesen elolvasni.
CZ Upozornění a výstrahy – přečtěte si před montáží.
SK Upozornenia a výstrahy – prečítajte si pred montážou.
SLO Opombe in opozorila – preberite pred montažo.
RU Примечания и предупреждения – прочитайте внимательно перед сборкой.
UA Зауваження та застереження – необхідно уважно ознайомитися перед початком монтажу.
LT Pastabos ir įspėjimai – perskaityti prieš montavimą.
LV Piezīmes un brīdinājumi – izlasīt pirms uzstādīšanas.
EST Märkused ja hoiatused – lugege enne kokkupanekut hoolikalt läbi.
RO Observații și avertizări – trebuie citite înainte de montare.
HR Napomene i upozorenja – pročitati prije početka montaže.
SR Napomene i upozorenja – pročitati pred početak montaže.
BG Бележки и предупреждения – да се прочете преди монтаж.
AL Shënime dhe paralajmërime – duhet të lexohen para montimit.

PL Wszystkie elementy mebli należy montować na płaskiej powierzchni. Do kompletu dołączono klucz służący do dokręcania śrub. Śruby należy wkręcać ręcznie i dopiero pod koniec montażu dokręcić je za pomocą specjalnego klucza. Klucz należy zachować do późniejszego użytku. Elementy mebli należy oczyścić przy pomocy wody z mydłem i miękkiej ściereczki. Meble przeznaczone są tylko do użytku domowego.

EN Please assemble each piece of furniture on a flat surface. A dedicated wrench is enclosed for assembly. It is recommended to assemble the screws and nuts manually, and only tighten them with the enclosed wrench at the end of the assembly process. It is highly recommended that you retain the wrench for future use. The pieces of furniture should only be cleaned using soap, water, and a soft cloth. The pieces of furniture are only intended for reasonable domestic use.

HU A bútort sik felületen kell összeszerelni. A csavarok meghúzásához használja a bútorttal együtt csomagolt kulcsot. A csavarokat előbb kézzel kell becsavarozni és csak a bútort összeszerelése végén kell azokat meghúzni a speciális kulccsal. A kulcsot kérjük megőrizni későbbi felhasználás céljából. A bútort szappanos vízzel és puha törülközővel tisztítani. A bútort otthoni használatra szolgál.

CZ Všechny části nábytku montujte na rovném povrchu. K soupravě je přiložen klíč sloužící k dotahování šroubů. Šrouby dotahujte ručně a teprve na konci montáže je dotáhněte pomocí speciálního klíče. Klíč uschovejte pro pozdější použití. Části nábytku očistěte vodou s mýdlem a měkkým hadříkem. Nábytek je určen pouze pro domácí použití.

SK Všetky časti nábytku montujte na rovnom povrchu. K súprave je priložený kľúč slúžiaci na utiahnutie skrutiek. Skrutky dotahujte ručne a až na konci montáže ich dotiahnite pomocou špeciálneho kľúča. Kľúč uschovajte pre neskoršie použitie. Časti nábytku očistite vodou s mydlom a mäkkou handričkou. Nábytok je určený len pre domáce použitie.

SLO Vse elemente pohištva montirajte na ravni površini. Set vsebuje izvirjač namenjen privijanju vijakov. Vijake privijte ročno in šele ob koncu montaže uporabite poseben izvijač. Izvirjač shranite za nadaljnjo uporabo. Elemente pohištva čistite z vodo z dodatkom mila in mehko krpo. Pohištvo je namenjeno le uporabi doma.

RU Каждую часть мебели необходимо собрать на плоской поверхности. Прилагаются специальные ключи для сборки. Рекомендуется собрать болты вручную, а после процесса сборки подтянуть их специальным ключом. Настоятельно рекомендуется сохранить ключ для дальнейшего использования. Мебель рекомендуется чистить мылом, водой и мягкой тканью. Мебель предназначен для рационального домашнего использования.

UA Усі елементи меблів потрібно монтувати на плоскій поверхні. У комплект входить ключ для затягування болтів. Болти необхідно збирати вручну, і лише в кінці монтажу затягнути їх за допомогою спеціального ключа. Ключ слід зберегти для подальшого використання. Елементи меблів потрібно очистити м'якою ганчіркою, зволоженою у воді з милом. Меблі призначені виключно для домашнього використання.

LT Visus baldų elementus reikia montuoti ant plokščio paviršiaus. Komplekte yra raktas varžtamams prisukti. Varžtus reikia įsukti rankiniu būdu ir montavimo pabaigoje priveržti naudojant specialų raktą. Raktą išsaugoti vėlesniam naudojimui. Baldų elementus nuvalyti vandeniu su muilu ir minkštu skudurėliu. Baldai yra skirti naudoti namuose.

LV Mēbeļu salikšana jāveic uz plakanas virsmas. Komplektā ietilpst atslēga skrūvju pievilksšanai. Skrūves ieskrūvēt ar roku un uzstādīšanas beigās pievilkt ar speciālu atslēgu. Atslēgu saglabāt turpmākai izmantošanai. Mēbeļu elementus attīrīt ar ūdeni ar ziepēm un mīkstu lupatīņu. Mēbeles ir paredzētas lietošanai mājās apstākļos.

EST Pange iga mööbliese kokku tasasel pinnal. Kokkupanekuks on kaasas spetsiaalne mutrivõti. Kruvid ja mutrid soovitatakse paigaldada käsitsi ning need tuleb kaasas oleva mutrivõtmeaga kinni keerata kokkupanekuprotsessi lõpus. Holdke mutrivõti edaspidiseks kasutamiseks alles. Puhastage mööbliesemed ainult seebi, vee ja pehme lapiga. Mööbliesemed on mõeldud ainult mõistlikuks koduseks kasutamiseks.

RO Toate elementele mobilei trebuie să fie montate pe suprafețe plane. La set a fost adăugată cheia care servește la strângerea șuruburilor. Șuruburile trebuie să fie înșurubate manual și apoi după finisarea montajului trebuie strânse cu ajutorul chei. Cheia trebuie păstrată pentru a putea fi folosită din nou. Elementele mobilei trebuie curățate cu ajutorul apei cu săpun și a unei cârpe moi. Moblia este destinată numai pentru uz casnic.

HR Sve radnje pri montaži elemenata namještaja obavljati na ravnoj površini. Uz set je priložen ključ za dovrtnanje vijaka. Vijke uvrtnati ručno i tek pri kraju montaže dovrnuti pomoću specijalnog ključa. Ključ čuvati za kasniju uporabu. Elemente namještaja prebrisati vodom s dodatkom sapuna i mekanom krpicom. Namještaj je namjenjen samo za kućnu uporabu.

SR Sve radnje pri montaži elemenata nameštaja obavljati na ravnoj površini. Uz set je priložen ključ za dovrtnanje zavrtnji. Zavrtnje uvrtnati ručno i tek pri kraju montaže dovrnuti pomoću specijalnog ključa. Ključ treba da se čuva za kasniju upotrebu. Elemente nameštaja prebrisati vodom sa dodatkom sapuna i mekanom krpicom. Nameštaj je namenjen samo za kućnu upotrebu.

BG Всичките компоненти на мебелите да се монтират върху плоска повърхност. Към комплекта добавено ключ за затягане на винтове. Винговете да се завинтва ръчно и чак на края на монтаж да се затяга със специален ключ. Ключът да се запази за по-късна употреба. Компонентите на мебелите да се почисти с вода със сапун и меко парцалче. Мебелите предназначени само за домашна употреба.

AL Të gjitha elementet e mobilieve duhet të montohen në një sipërfaqe të sheshtë. Kompletit iu bashkëngjijt një çelës që shërben për të mbërthyer vidat. Vidat duhet të mbërthehen me dorë dhe vetëm në fund të montimit duhet të shtërngohen me ndihmën e çelësit special. Çelësi duhet ruajtur për përdorim të mëvonshëm. Elementet e mobilieve duhet të pastrohen me ndihmën e ujit me sapun dhe me leckë të butë. Mobiliet janë planifikuar vetëm për përdorim shtëpie.

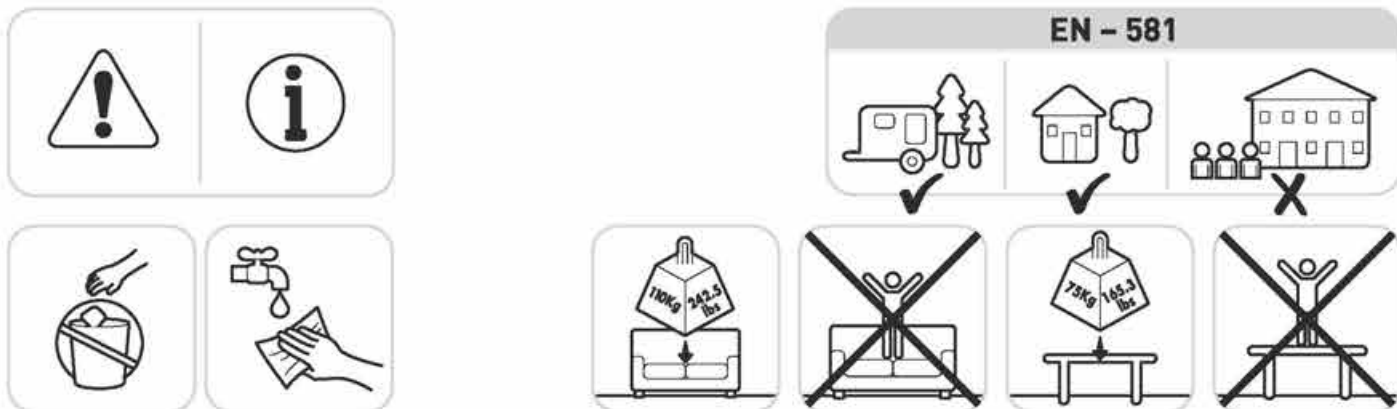

PL W PRZYPADKU BRAKUJĄCYCH BĄDŹ ZŁAMANYCH CZĘŚCI PROSIMY NIE ZWRACAĆ PRODUKTU DO SKLEPU.
W takim przypadku prosimy zalogować się na naszej stronie internetowej lub skontaktować się z Działem Obsługi Klienta:

EN IF THERE ARE MISSING OR BROKEN PARTS, PLEASE DO NOT RETURN THE PRODUCT TO THE STORE.
Please log onto our website, or contact Customer Service at:

HU HIÁNYZÓ VAGY TÖRÖTT ELEM EK ESETÉN KÉRJÜK NE KÜLDJE VISSZA A TERMÉKET AZ ÜZLETBE.
Ebben az esetben jelentkezzen be az internetes oldalunkon vagy lépjen kapcsolatba az Ügyfélszolgálati Osztállyal:

CZ V PŘÍPADĚ CHYBĚJÍCÍCH NEBO POŠKOZENÝCH SOUČÁSTÍ PROSÍME NEVRACEJTE PRODUKT DO OBCHODU.
V takovém případě se přihlaste na naši internetovou stránku nebo kontaktujte oddělení péče o zákazníka:

SK V PRÍPADE CHÝBAJÚCICH ALEBO POŠKODENÝCH SÚČASŤÍ PROSÍME NEVRACAJTE PRODUKT DO OBCHODU.
V takom prípade sa prihláste na našu internetovú stránku alebo kontaktujte oddelenie starostlivosti o zákazníka:

SLO V PRIMERU, ČE NI VSEH DELOV OZIROMA SO DELI POLOMLJENI, PROSIMO, DA NE VRAČATE IZDELKA V TRGOVINO.
V takšnem primeru prosimo, da se prijavite na naši spletni strani oziroma se obrnete na Oddelek za storitve za stranke:

RU В СЛУЧАЙ, ЧЕ ИМА ЛИПСВАЩИ ИЛИ СЧУПЕНИ ЧАСТИ, ВИ МОЛИМ ДА НЕ ВРЪЩАТЕ ПРОДУКТА В МАГАЗИНА.
Влезте на наш сайт или се свържете с отдел "Обслужване на клиенти":

UA В СЛУЧАЄ ОТСУТСТВИЯ ІЛИ БРАКОВАННИХ ЧАСТЕЙ ПРОСЬБА НЕ ВОЗВРАЩАТЬ ПРОДУКТ В МАГАЗИН.
В данном случае просьба зарегистрироваться на нашем веб-сайте или связаться с Отделом Обслуживания Клиентов:

LT DALIŲ TRŪKUMO AR SULŪŽIMO ATVEJU PRAŠOME PRODUKTO NEGRAŽINTI Į PARDUOTUVĘ.
Tokiu atveju prašome prisijungti mūsų internetinėje svetainėje arba susisiekti su Kliento aptarnavimo skyriumi:

LV DETAĻU TRŪKUMA VAI SABOJĀTU DETAĻU GADĪJUMĀ LŪDZAM PRODUKTU NEATDOT VEIKALĀ.
Tādā gadījumā lūdzam ieloties mūsu interneta lapā vai kontaktēties ar Klienta Apkalpošanas Daļu:

EST KUI AVASTATE, ET TOODE EI OLE KOMPLEKTNE VÕI ON PURUNENUD, ÄRGE SAATKE SEDA MÜÜJALE TAGASI.
Probleemi lahendamiseks võtke palun ühendust meie klienditeenindusega aadressil:

RO DACĂ SÎNT PIESE CARE LIPSESC SAU CARE SÎNT RUPTE VĂ ROG SĂ NU RETURNAȚI PRODUSUL LA MAGAZINUL.
În acest caz vă rog să vă logați pe pagina Internet sau să contactați Serviciul Clienți:

HR U SLUČAJU NEDOSTATKA ILI SLOMLJENIH DIJELOVA, MOLIMO NEMOJTE VRATITI PROIZVOD U TRGOVINU.
U tom slučaju, prijavite se na našoj web stranici ili kontaktirajte službu za korisnike:

SR U SLUČAJU AKO NE DOSTAJU DELOVI ILI AKO SU POLOMLJENI, MOLIMO VAS NEMOJTE DA VRATITE PROIZVOD U PRODAVNICU.
U tom slučaju, molimo vas da se prijavite na našem sajtu ili kontaktirajte Korisnički servis:

BG НЁСЕ ЈУ МУНГОЈНЁ ДИСА ПЈЕСЁ ОСЕ КЕНИ ПЈЕСЁ ТЁ ТЫЕРА ЈУ ЛУТЕМИ ТА МОС КТНЕНИ ПРОДУКТИН НЁ ДЫQАНИН.
Нё кетё раст ју лутеми тё идентификенени нё вебфаен тонё тё интернетит осе тё контактони Дегён е Шёрбимит тё Клиентит:

AL У ВИПАДКУ ВІДСУТНОСТІ АБО ПОШКОДЖЕННЯ ЧАСТИН ПРОХАННЯ НЕ ПОВЕРТАТИ ПРОДУКТ В МАГАЗИН.
В даному випадку прохання зареєструватися на нашому веб-сайті або зв'язатися з Відділом Обслуговування Клиентів:

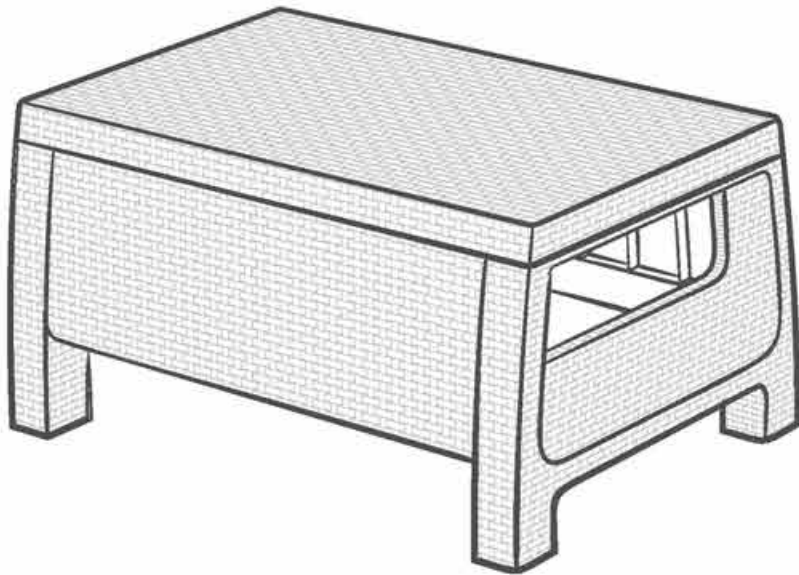

Zawartość | Contents | Tartalom | Obsah | Obsah | Vsebina | Содержание | Комплектація | Turinys | Saturs | Sisu | Conținut | Sadržaj | Sadržaj | Съдържание | Përmbajtja

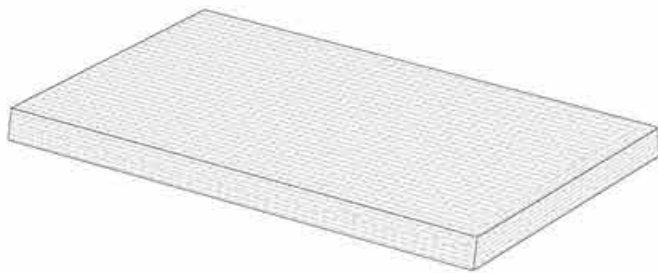

Tx1

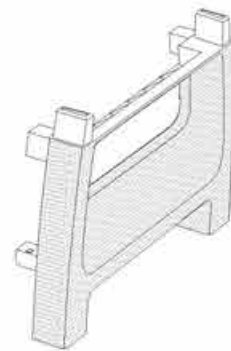

SSTx2

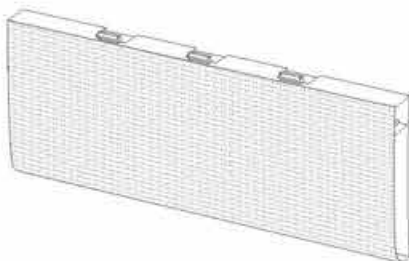

LSTx2



LPx4

1

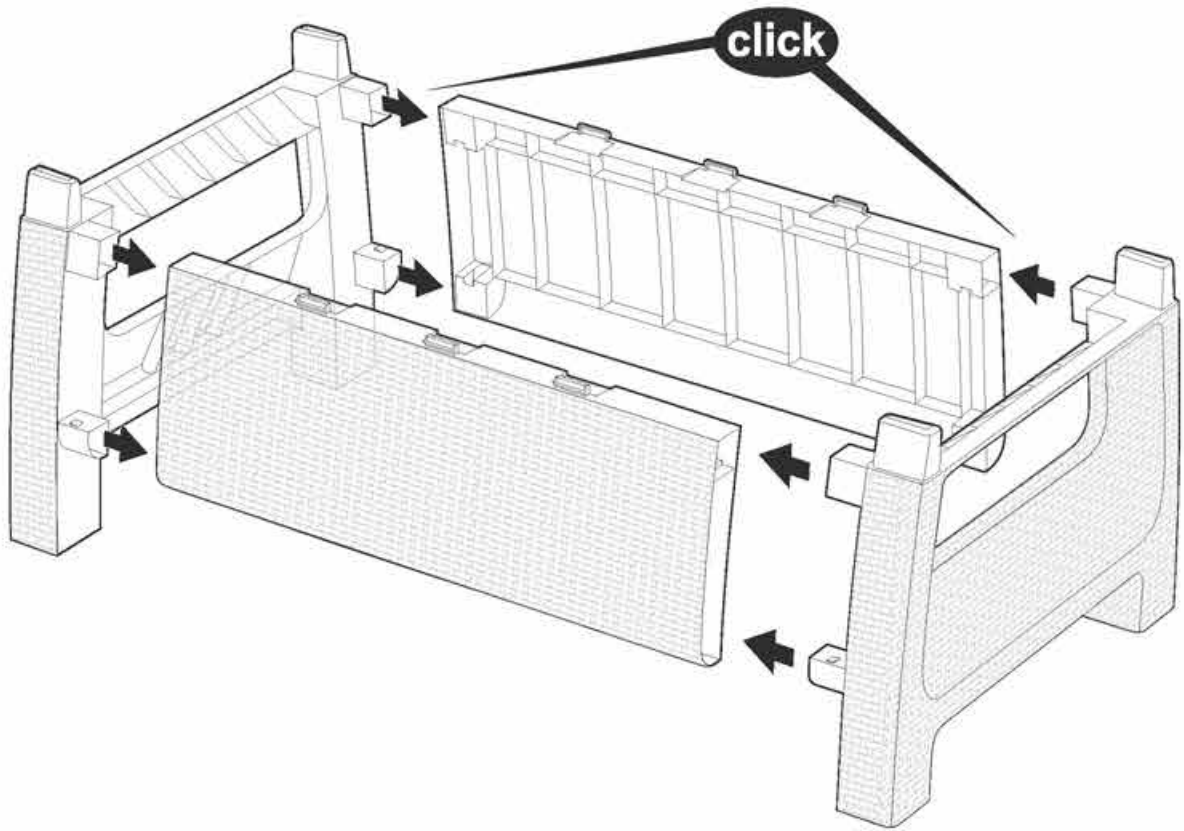



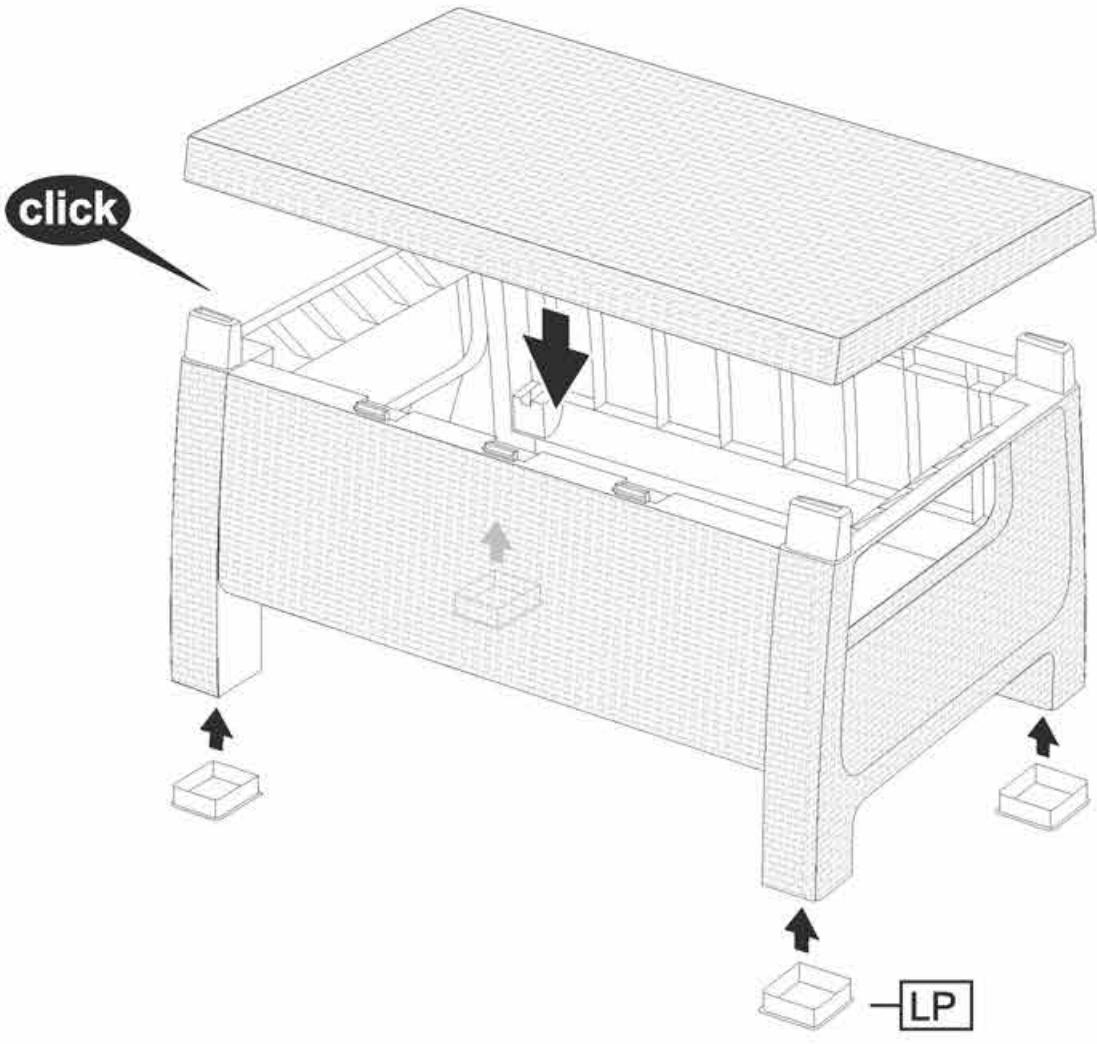
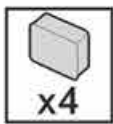

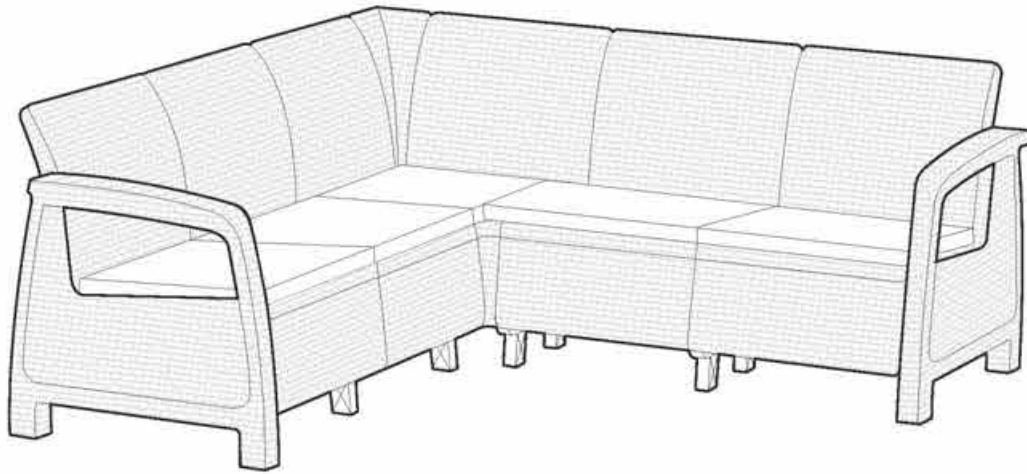



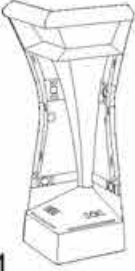



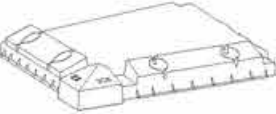
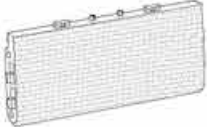





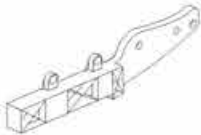
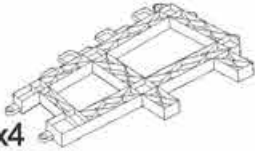





2





Zawartość | Contents | Tartalom | Obsah | Obsah | Vsebina | Содержание | Комплектація | Turinys | Saturs | Sisu | Conținut | Sadržaj | Sadržaj | Съдържание | Përmbajtja

 CAx1	 CBx1	 CCx1	 CDx1	 CEx1				
 CSx1	 FBx10	 LSx1		 RSx1				
 Bx6	 Sx4	 Rx1	 Cx4					
 ML1x4	 MLx4	 3x6	 4x6	 CLPx1	 LBNx6	 RBNx6	 Lx1	 Rx1
 1x6	 2x6	 LPx4	 NSx6	 Nx14	 SCx60	 Kx2		

1

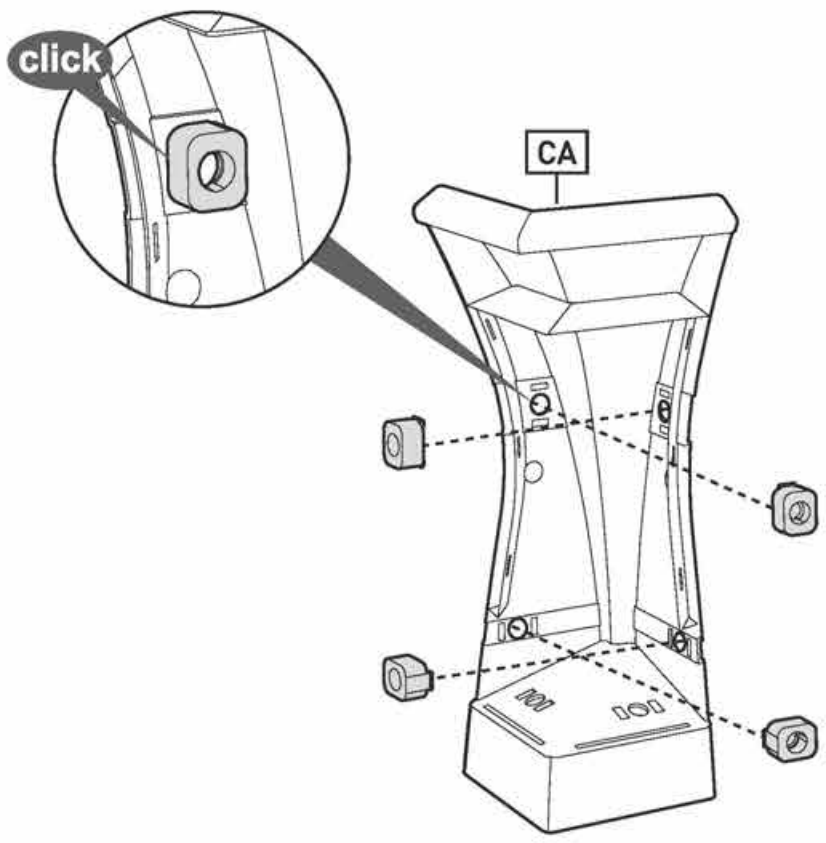

2

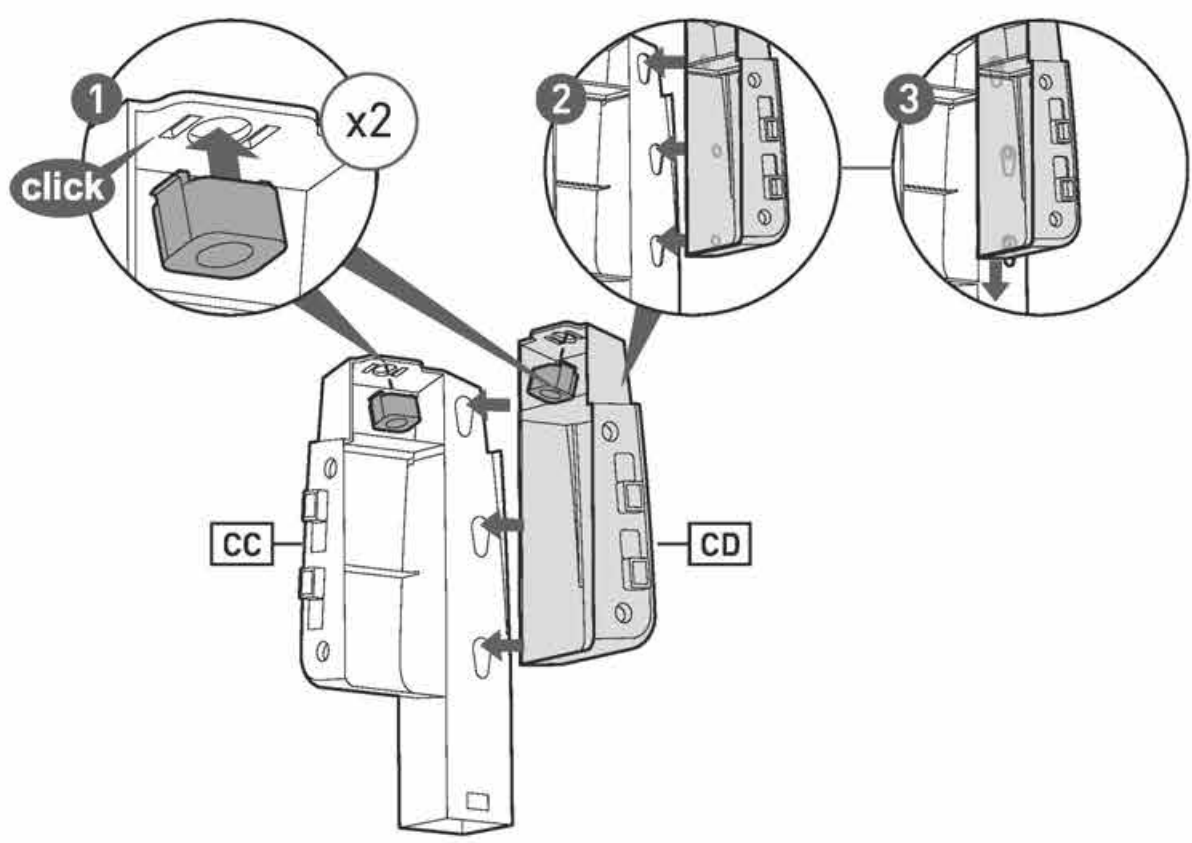
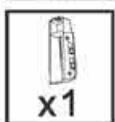



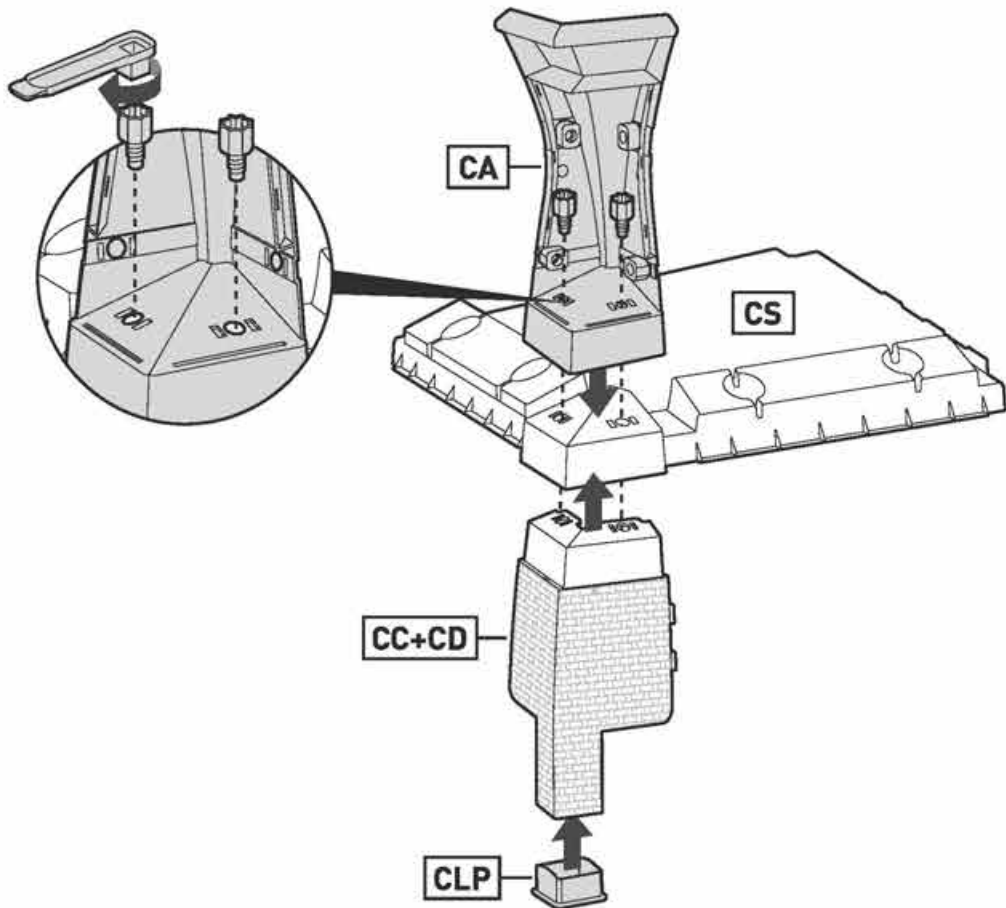

3

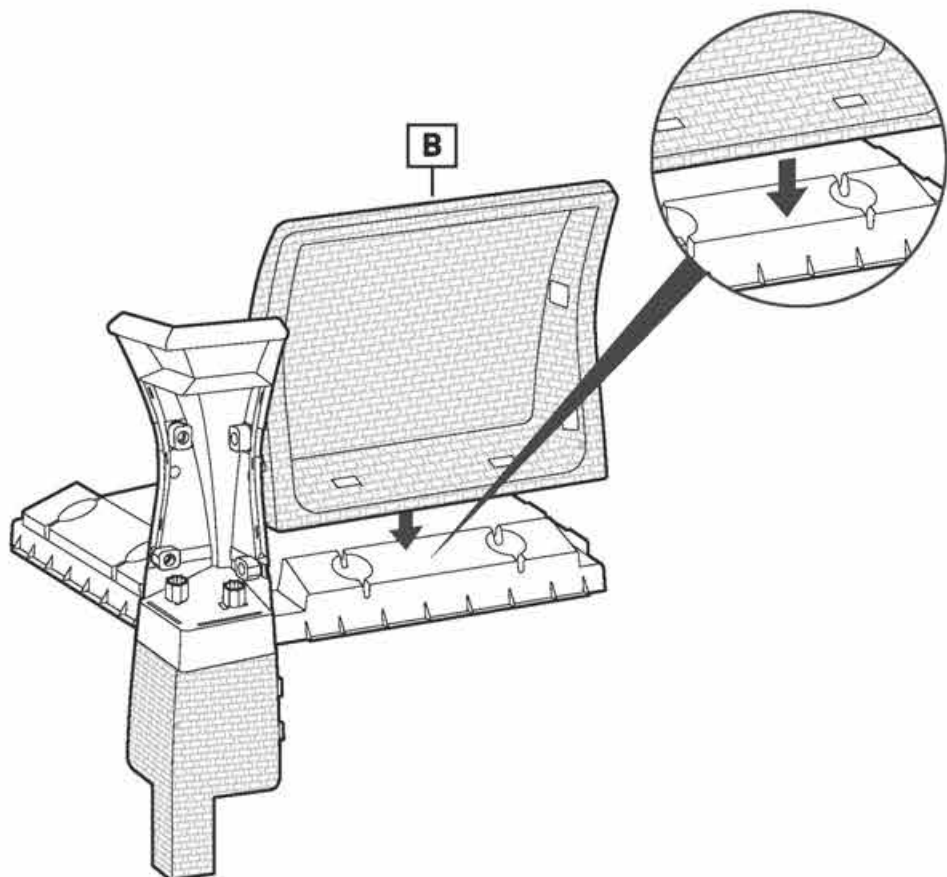

4



5

- 
x1
- 
x1
- 
x4
- 

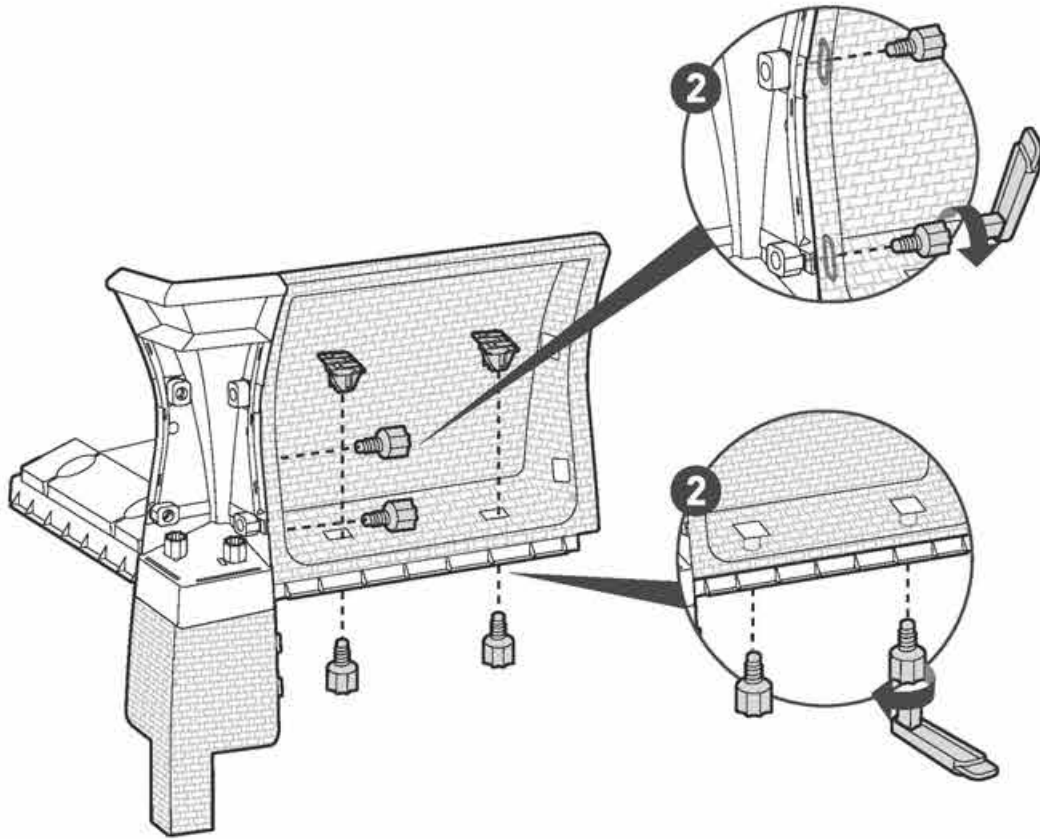

6

- 
x1

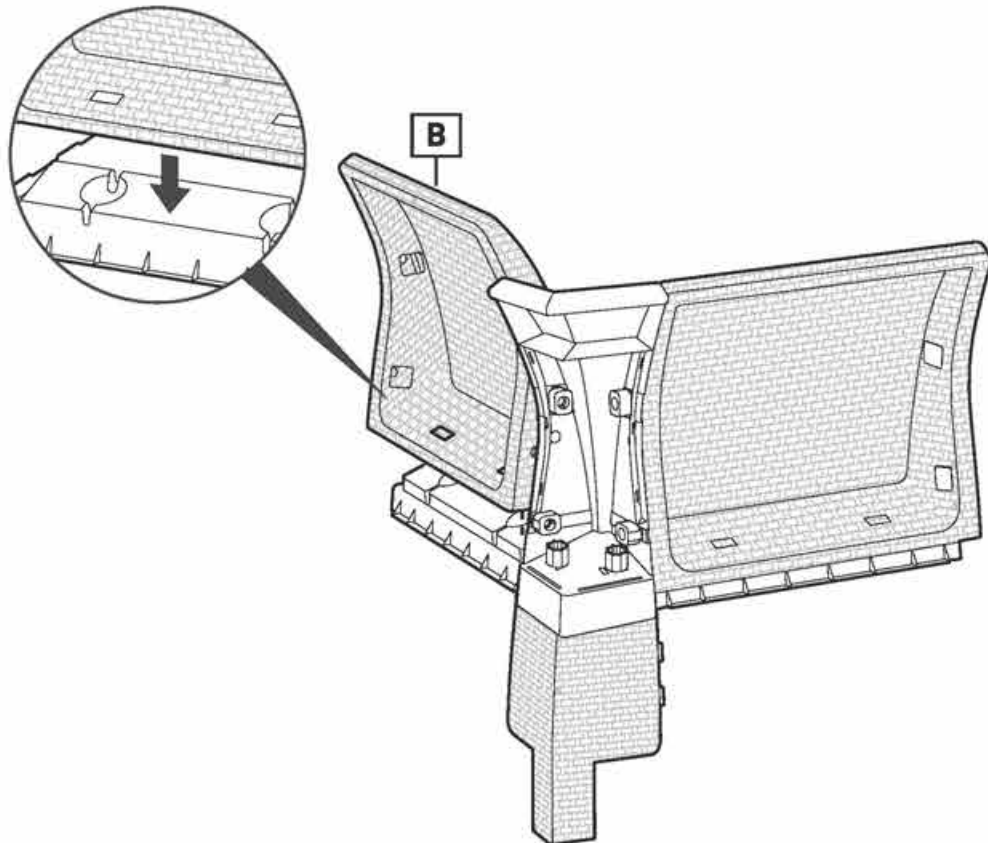

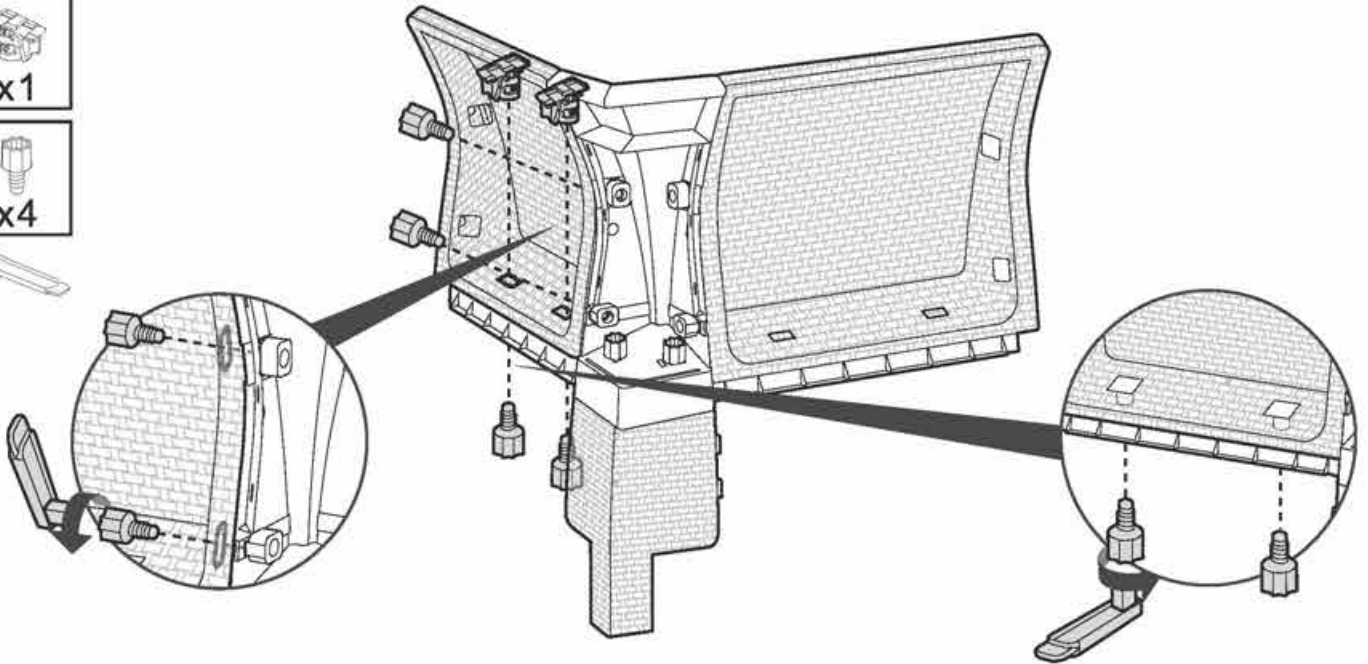

7

- 
x1
- 
x1
- 
x4



8

- 
x2
- 
x4

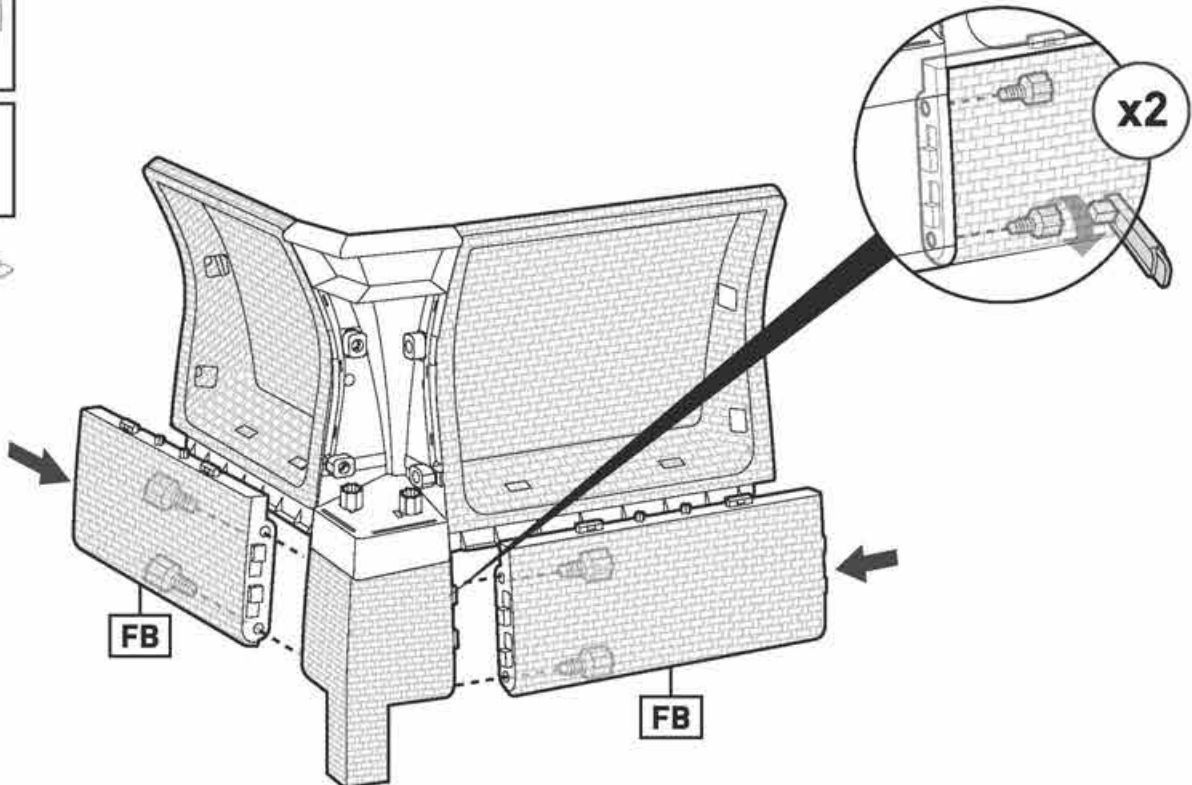

9

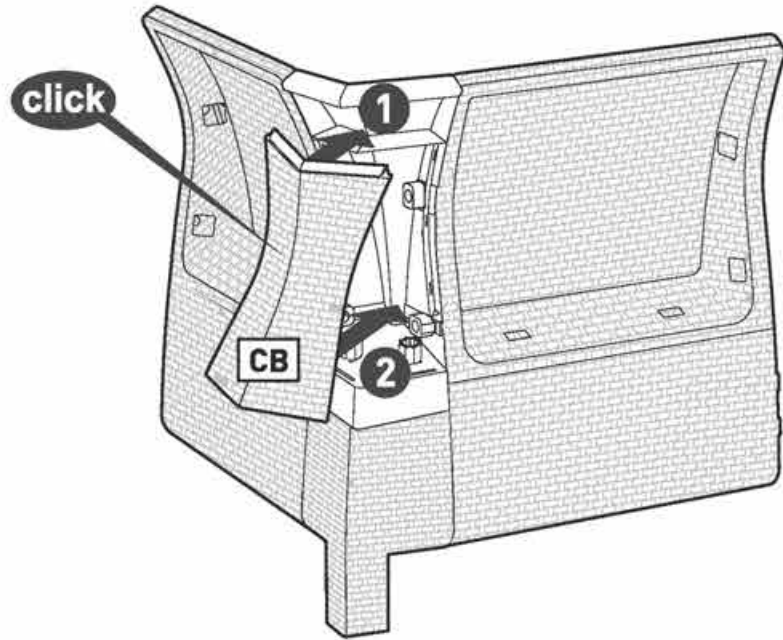
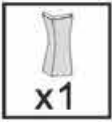

10

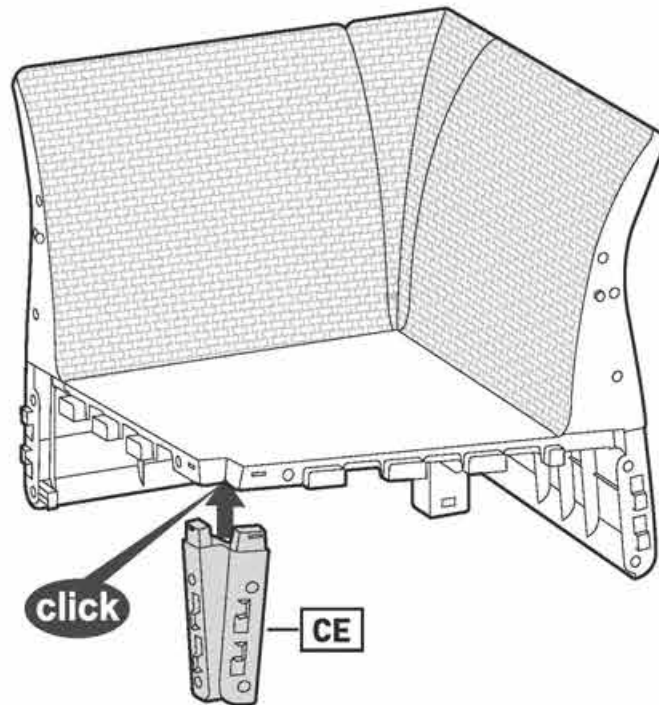

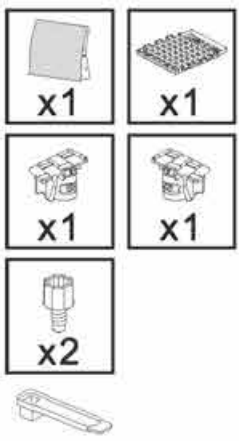
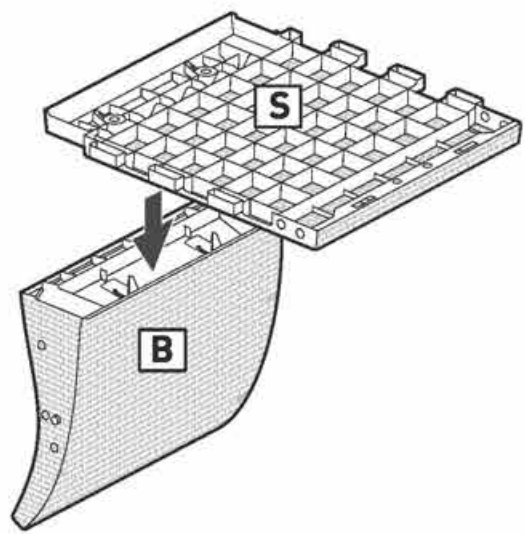

X4

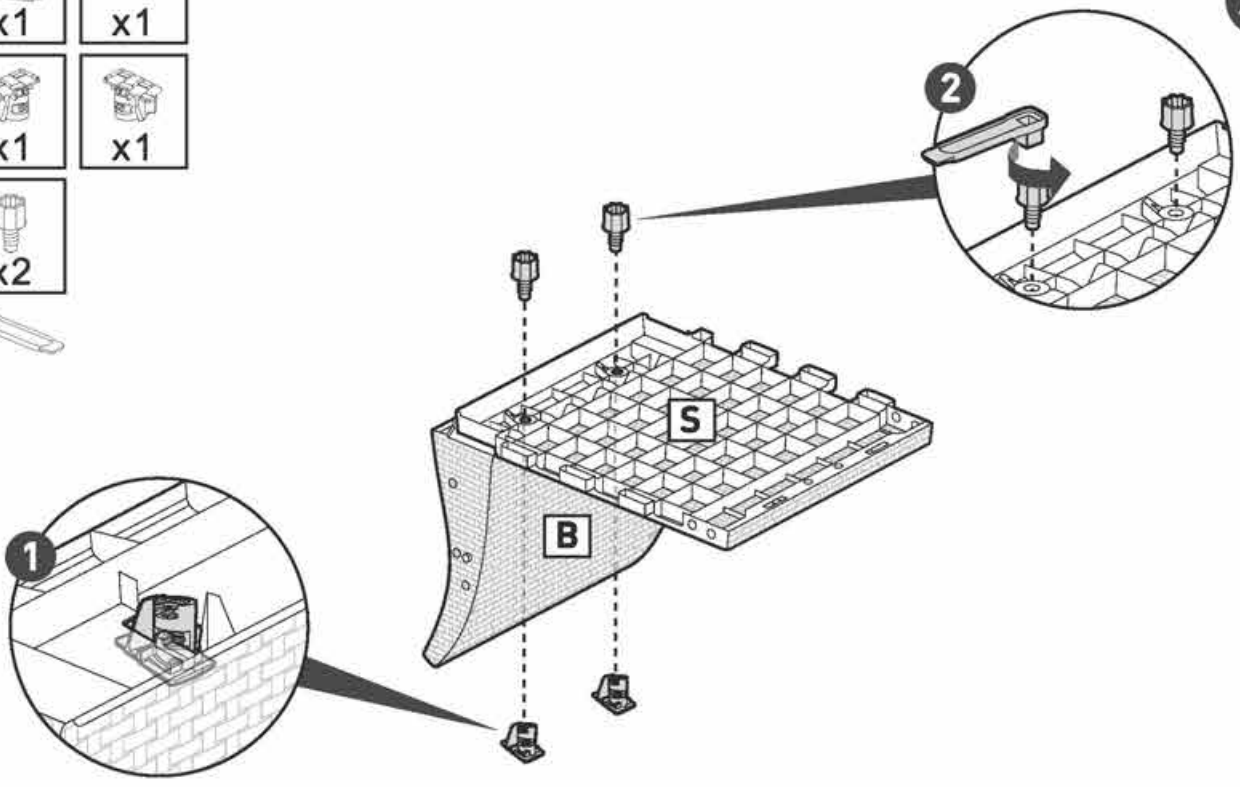

13

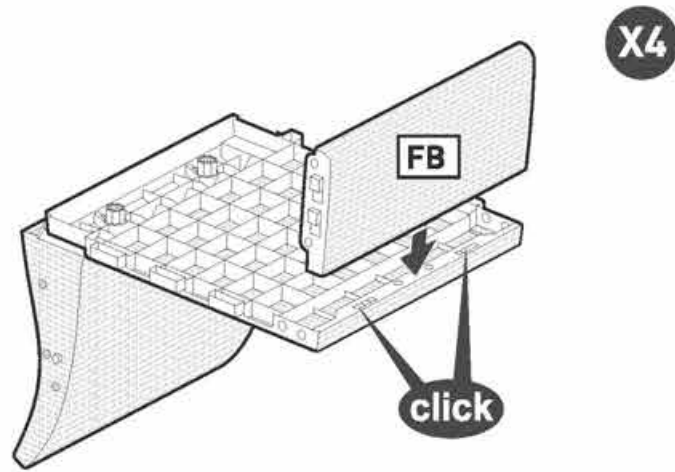

14

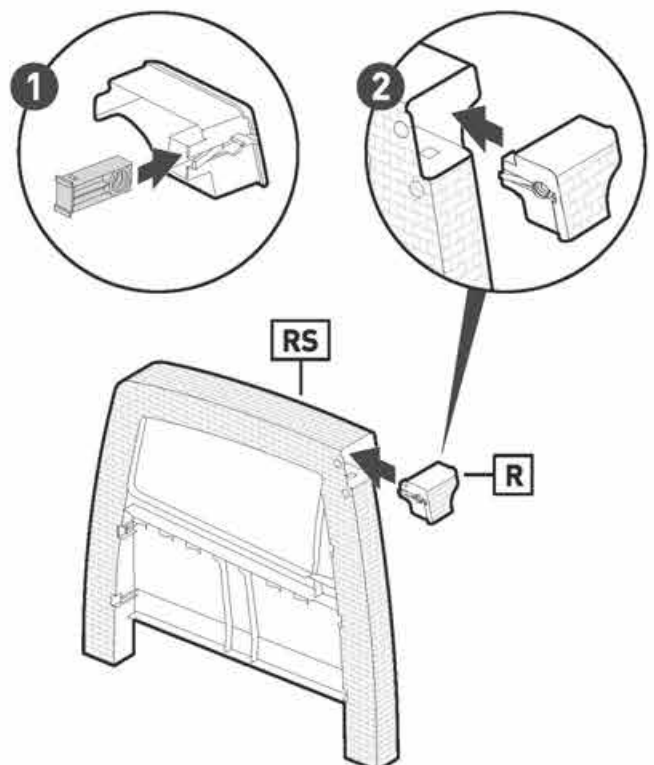
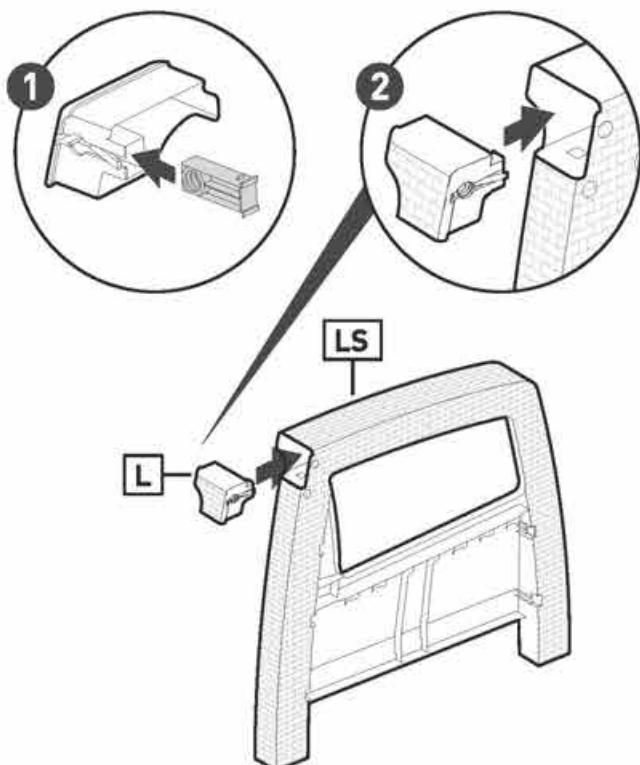
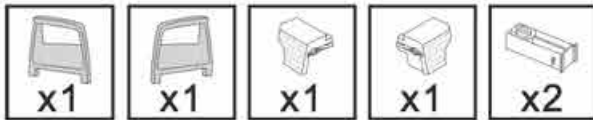

15

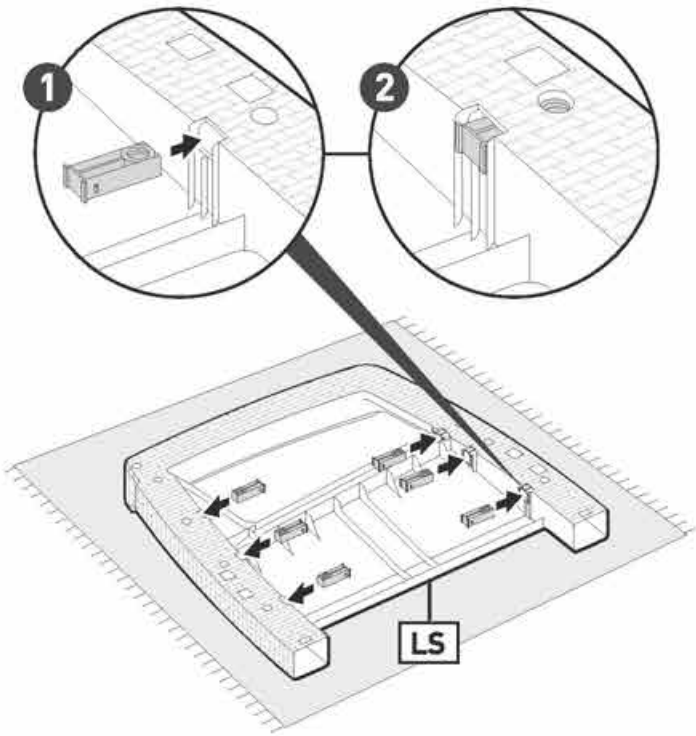

X2

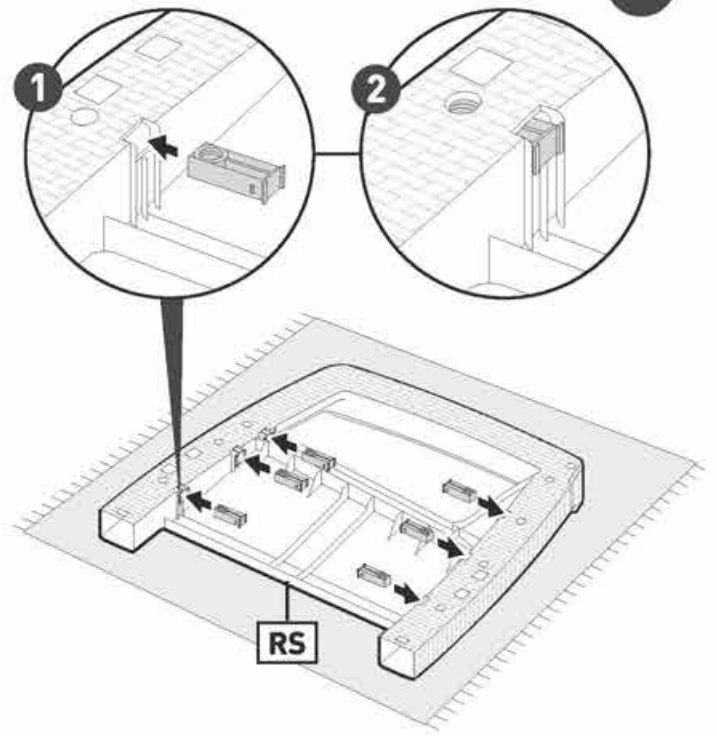

16

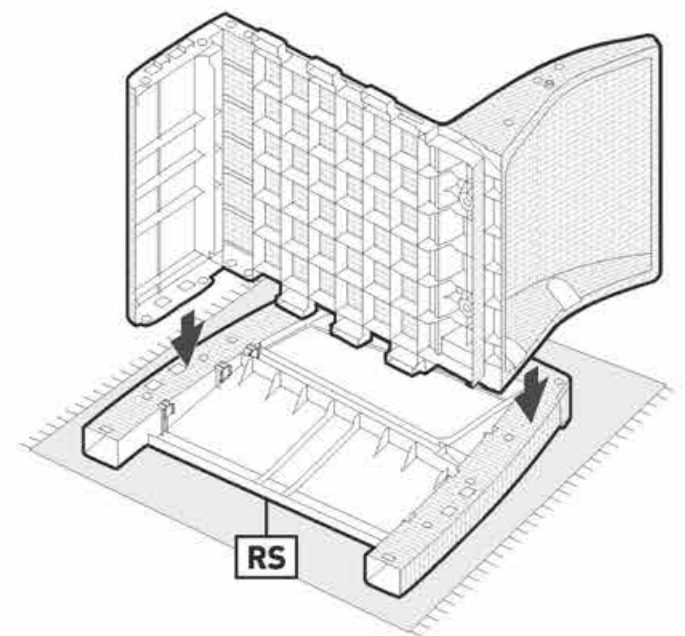
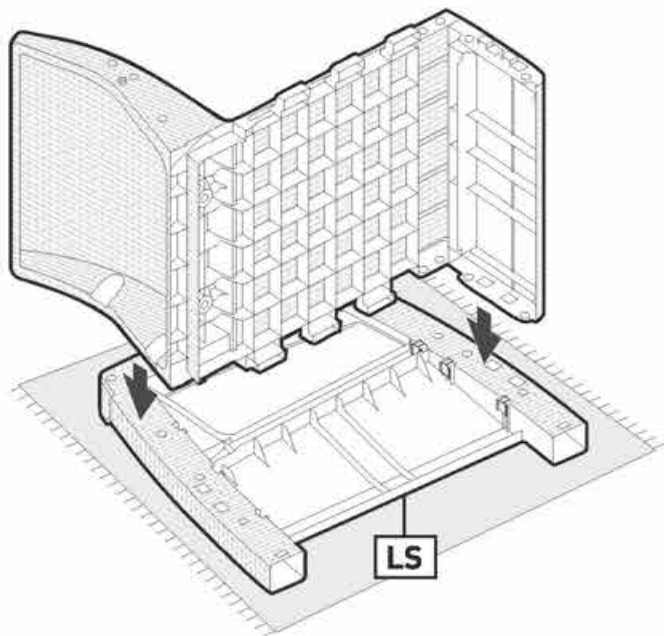

17

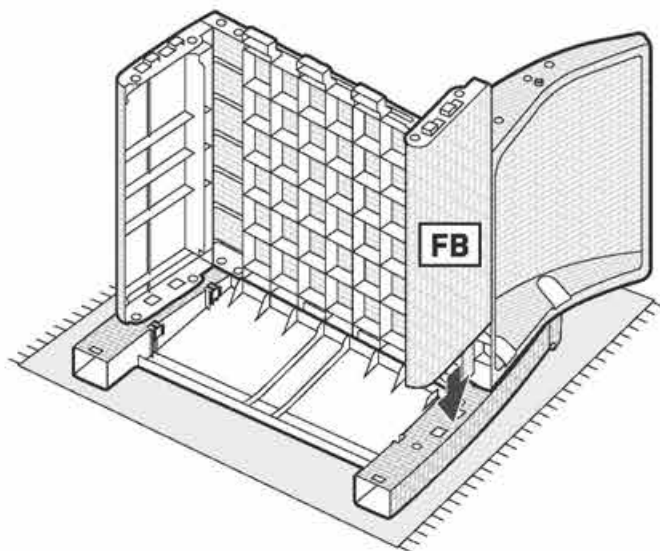
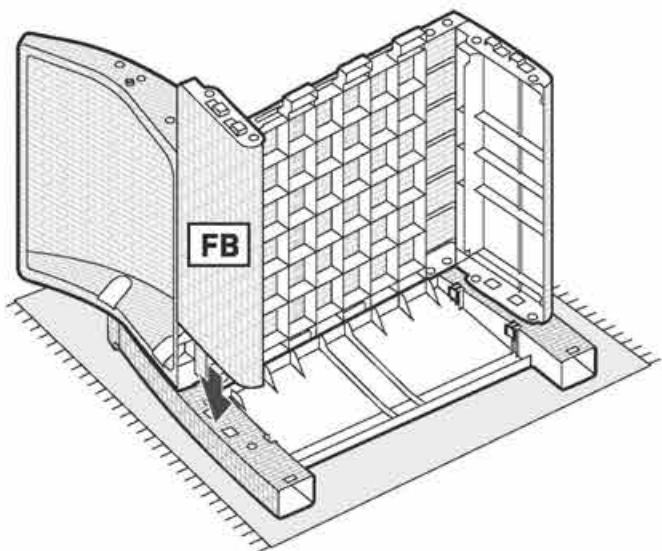

18

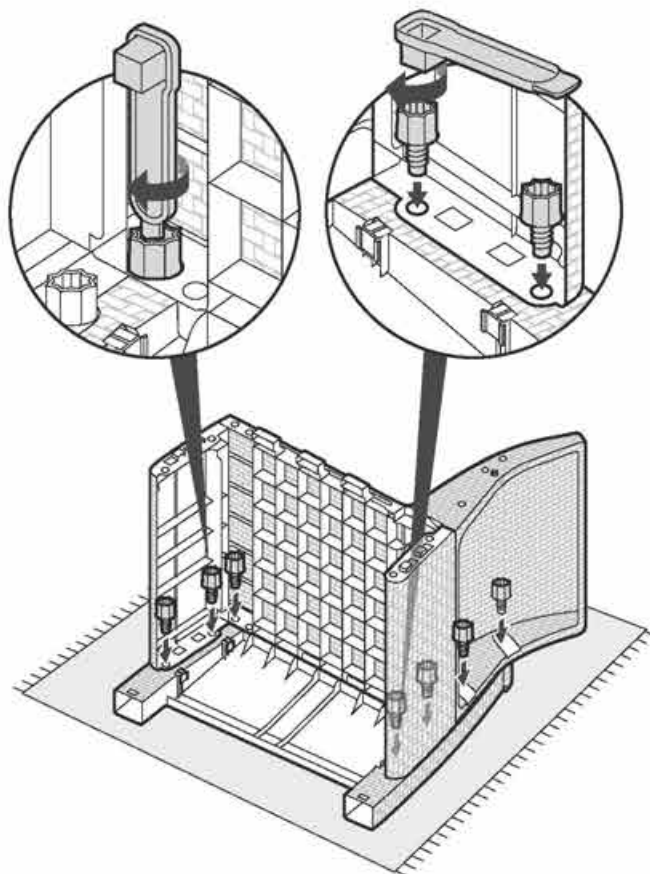
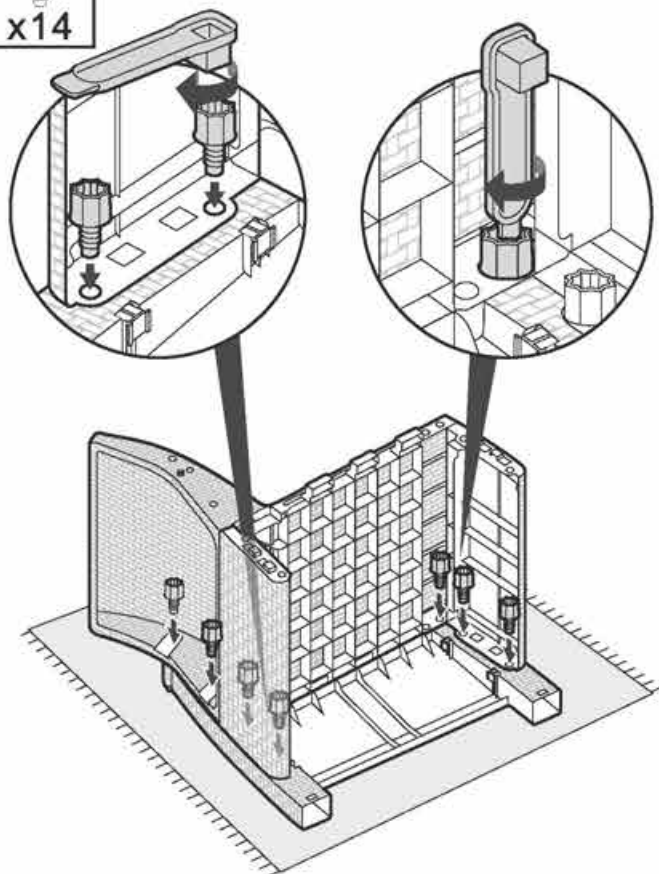

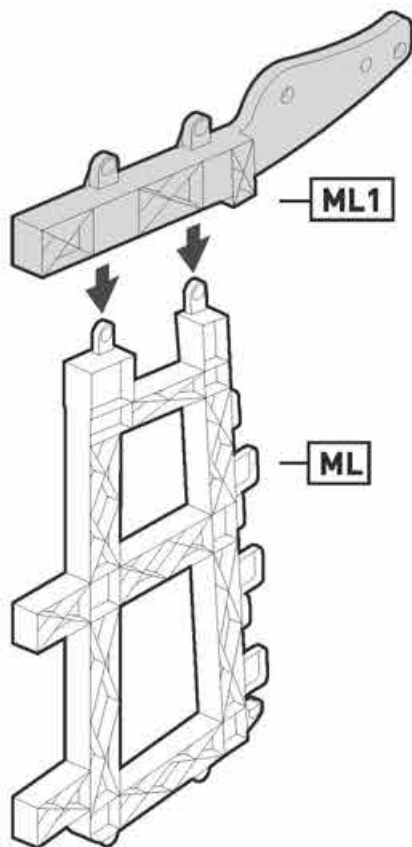
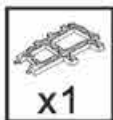
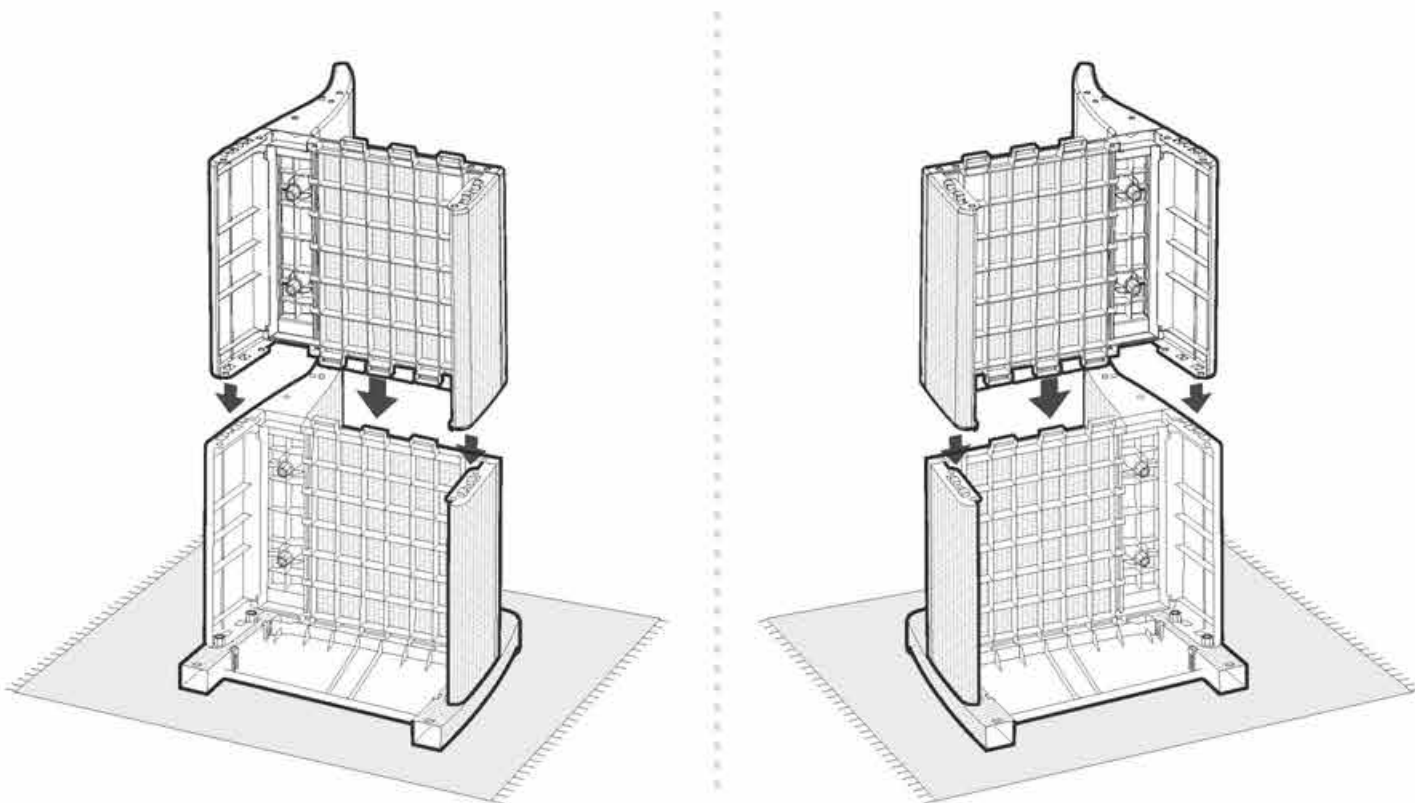

X4

21

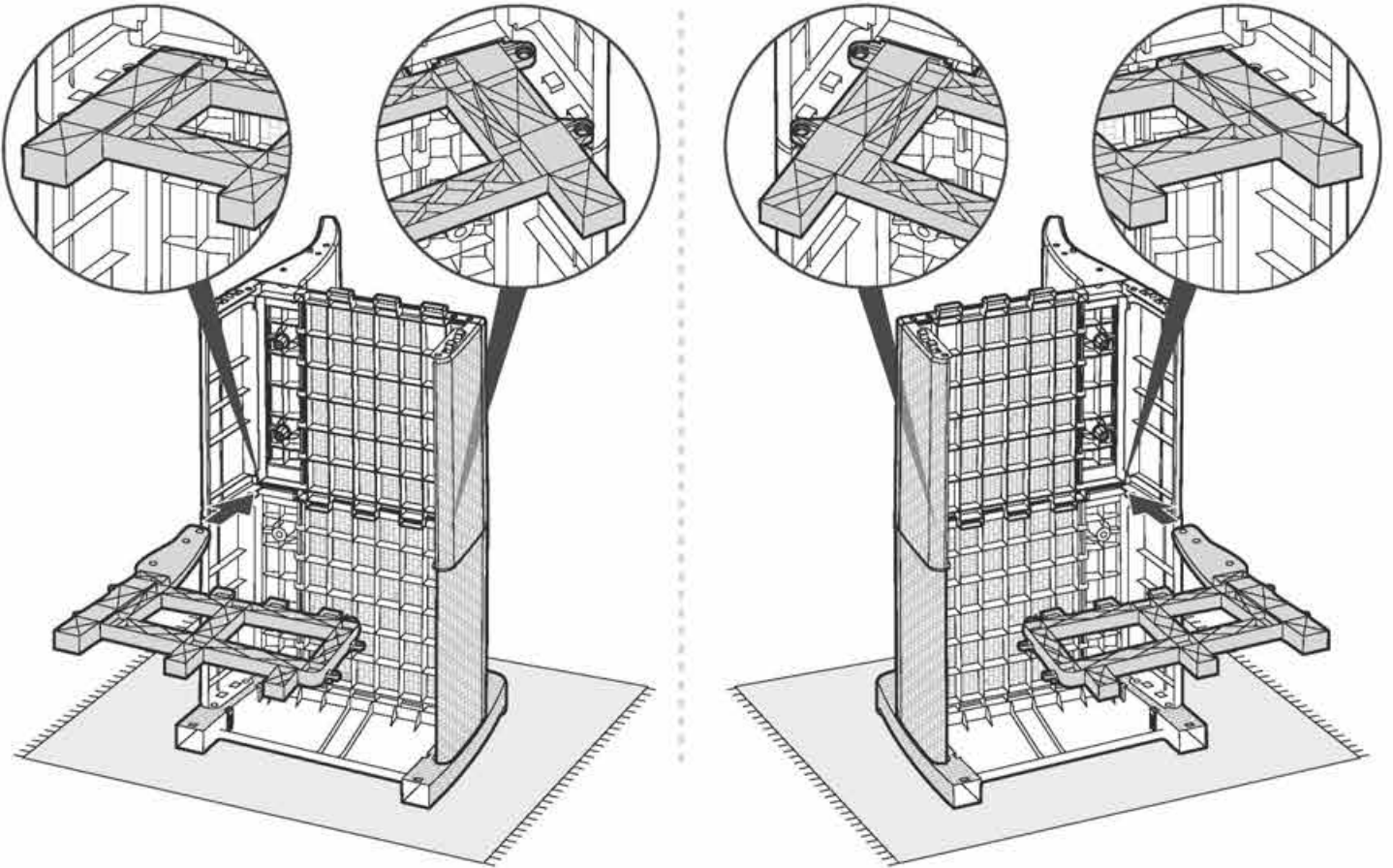

22

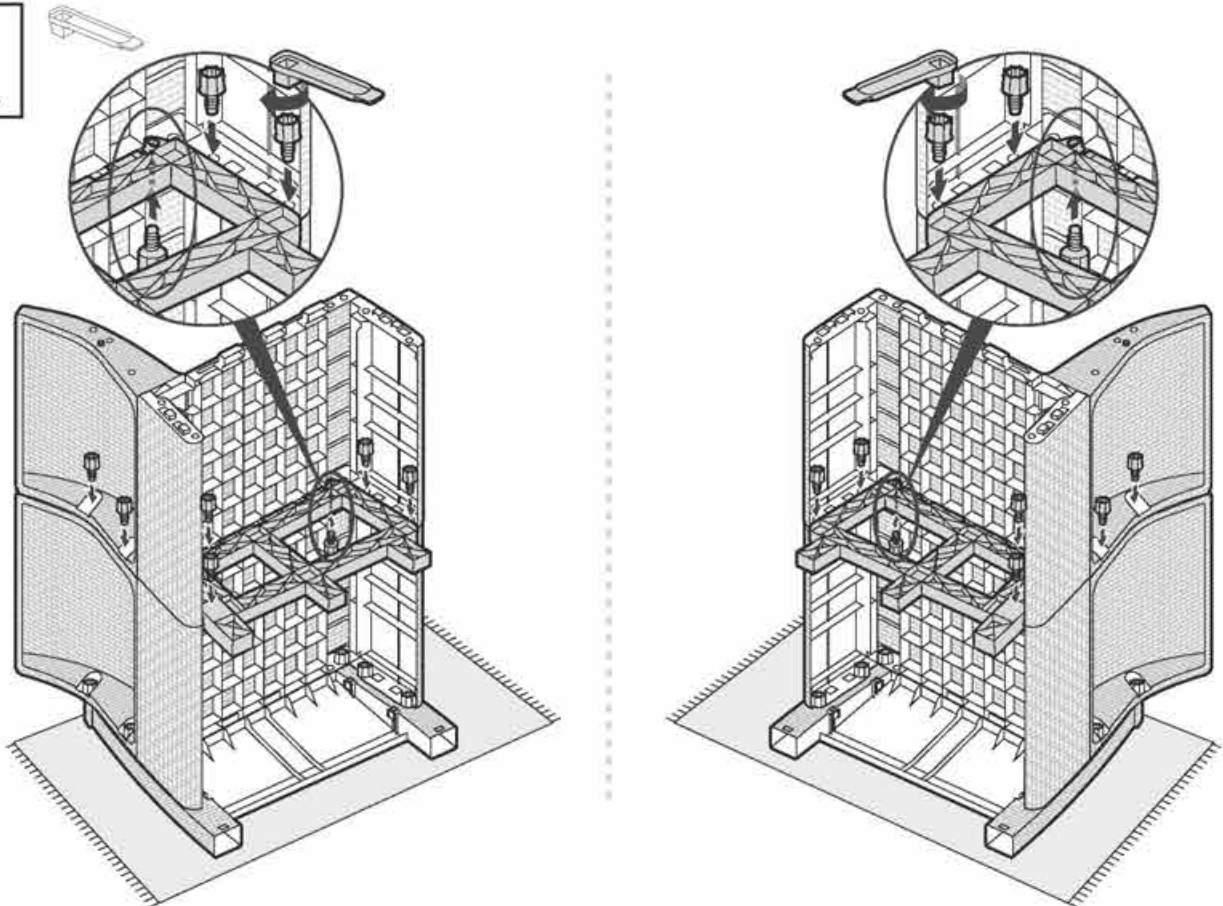

23

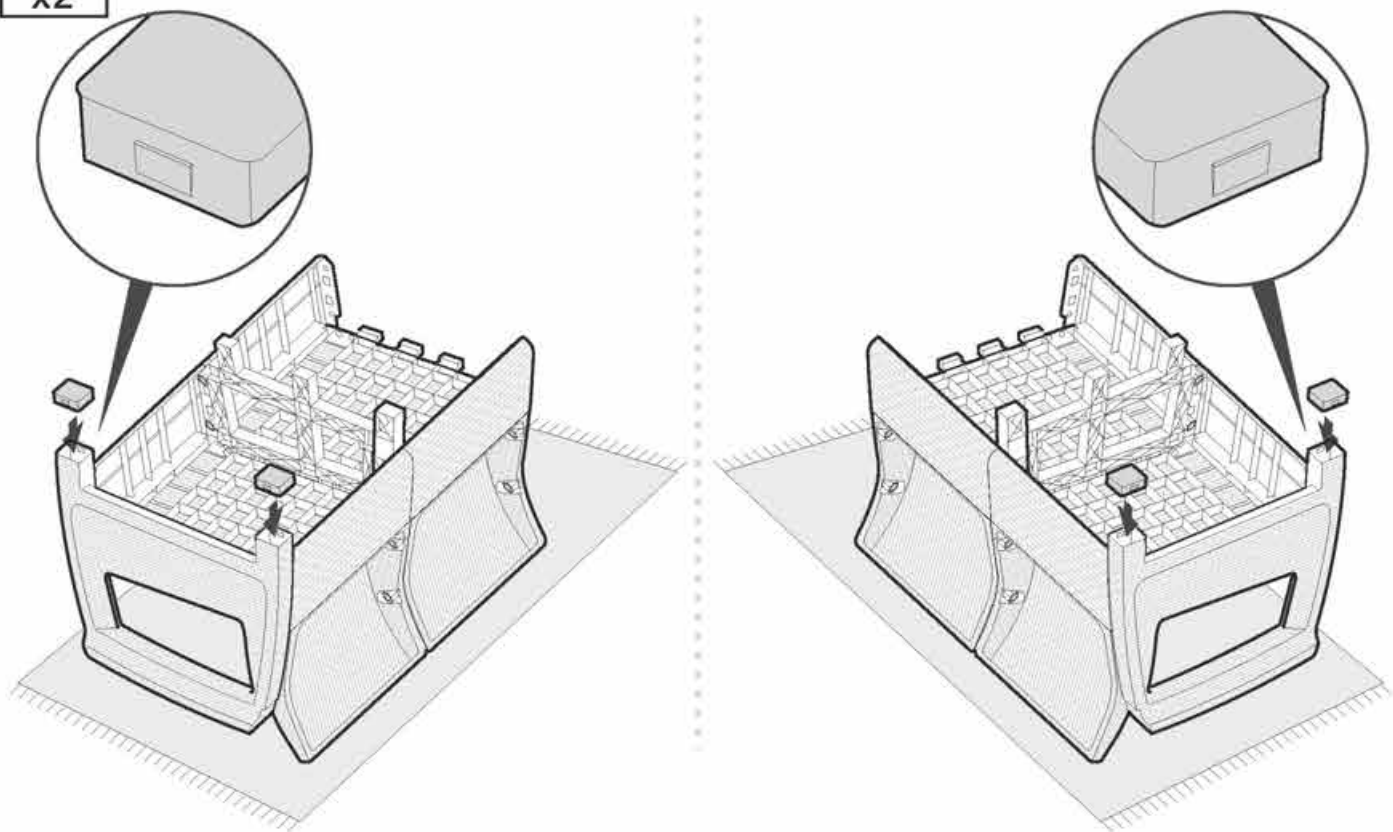
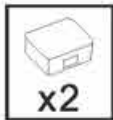

24

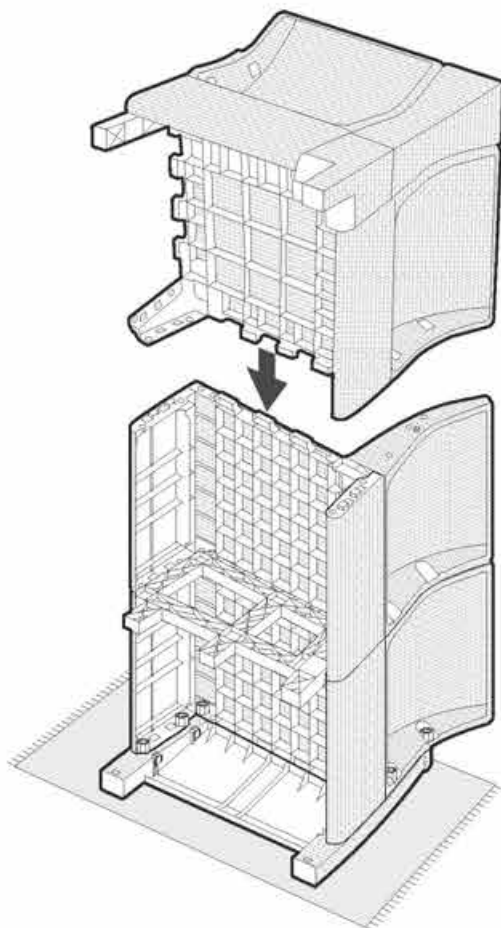

25

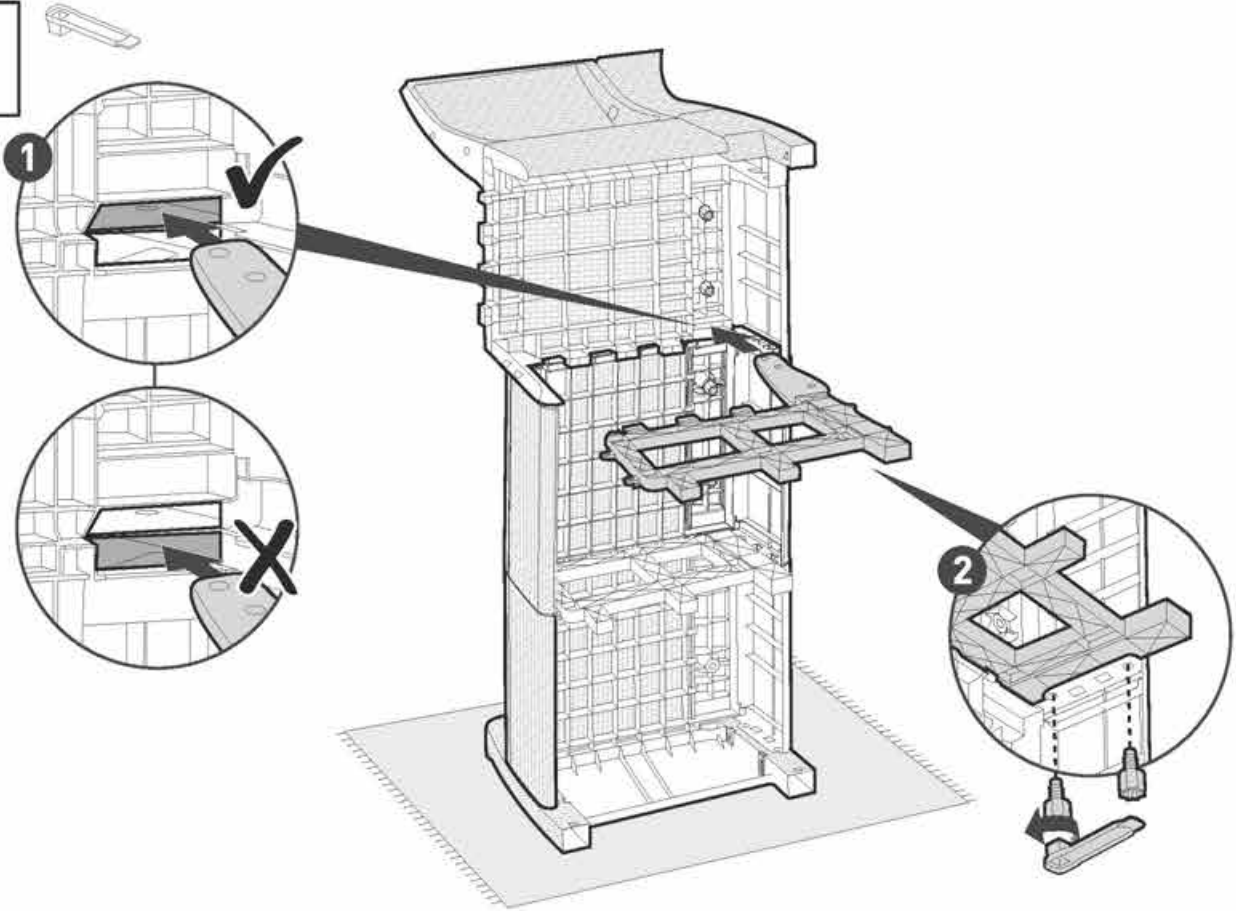

26

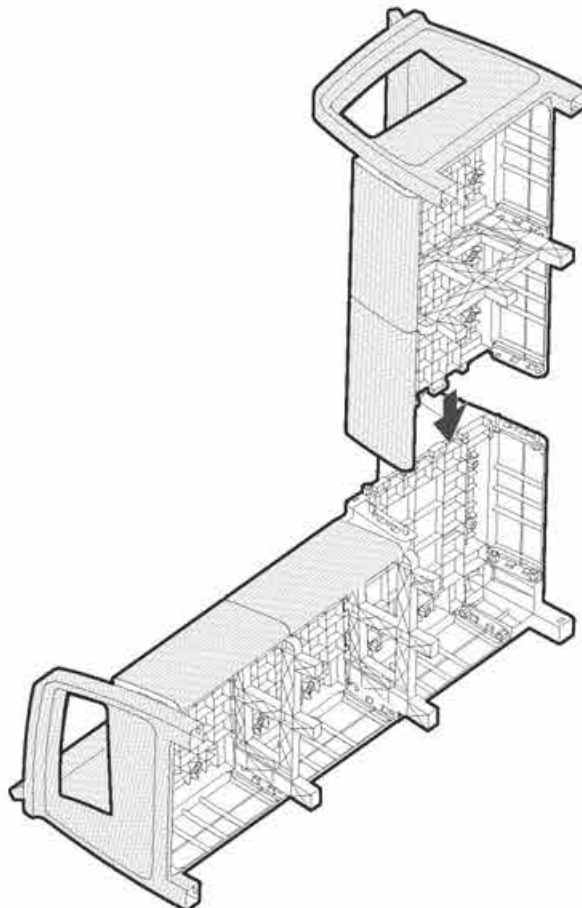

27

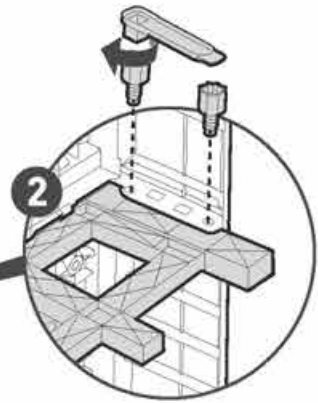
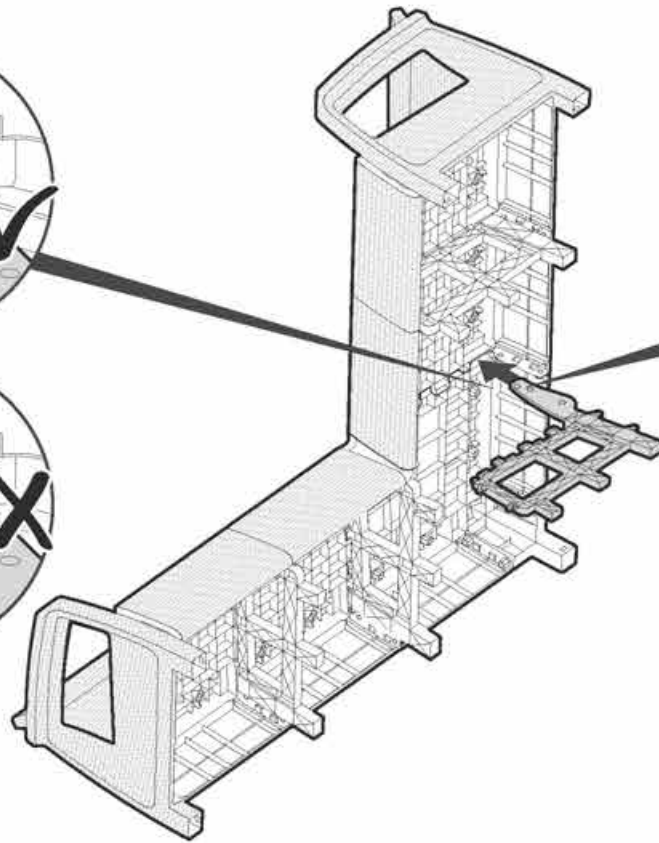
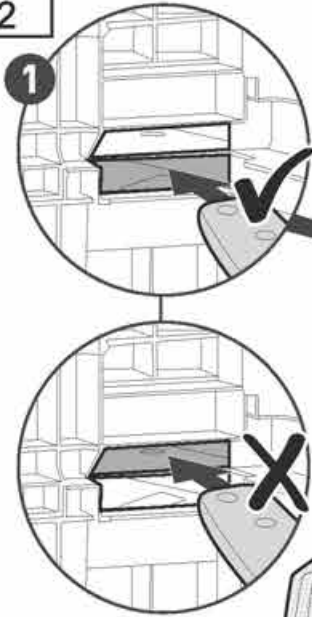

28

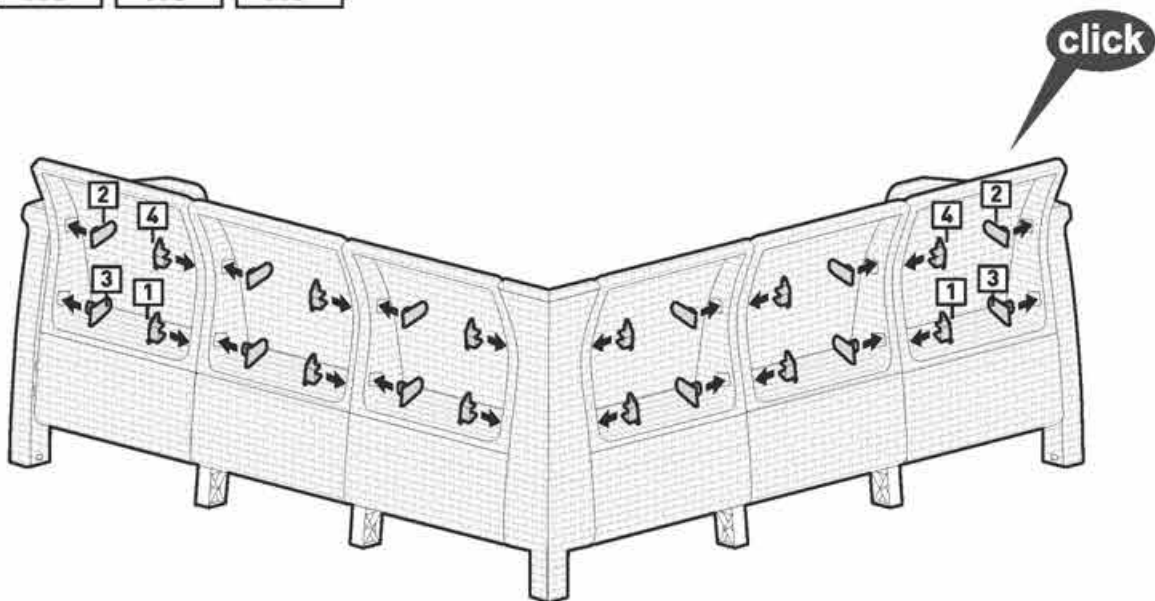

29

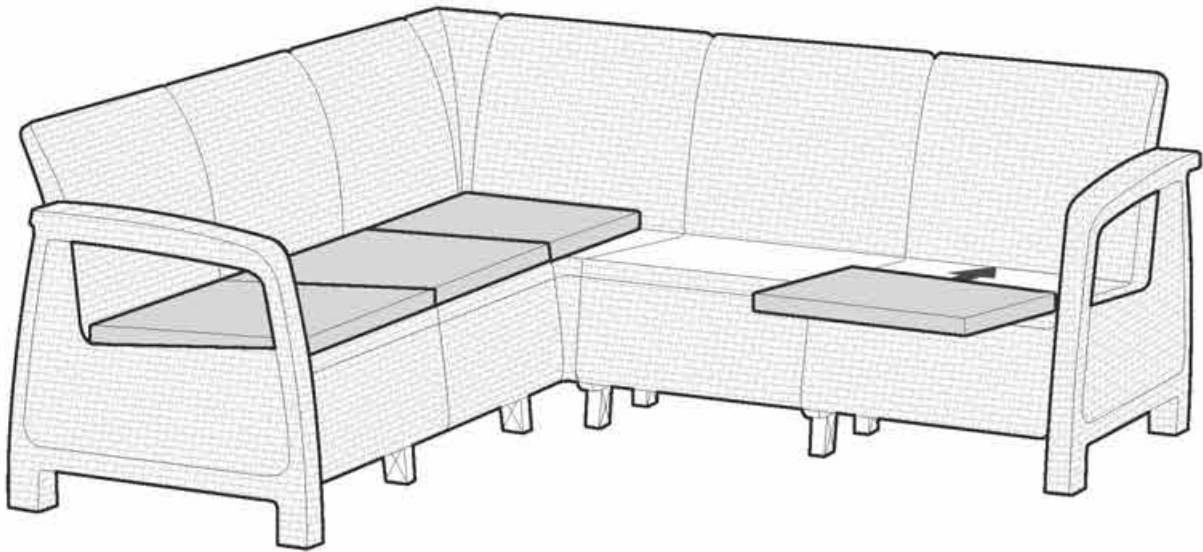

30

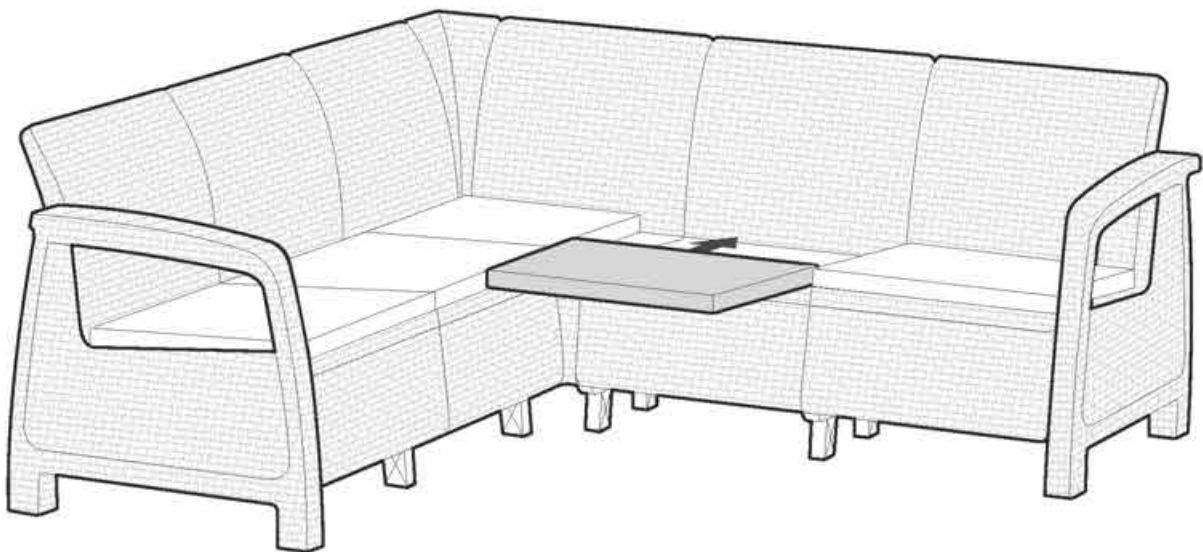

C O R F U



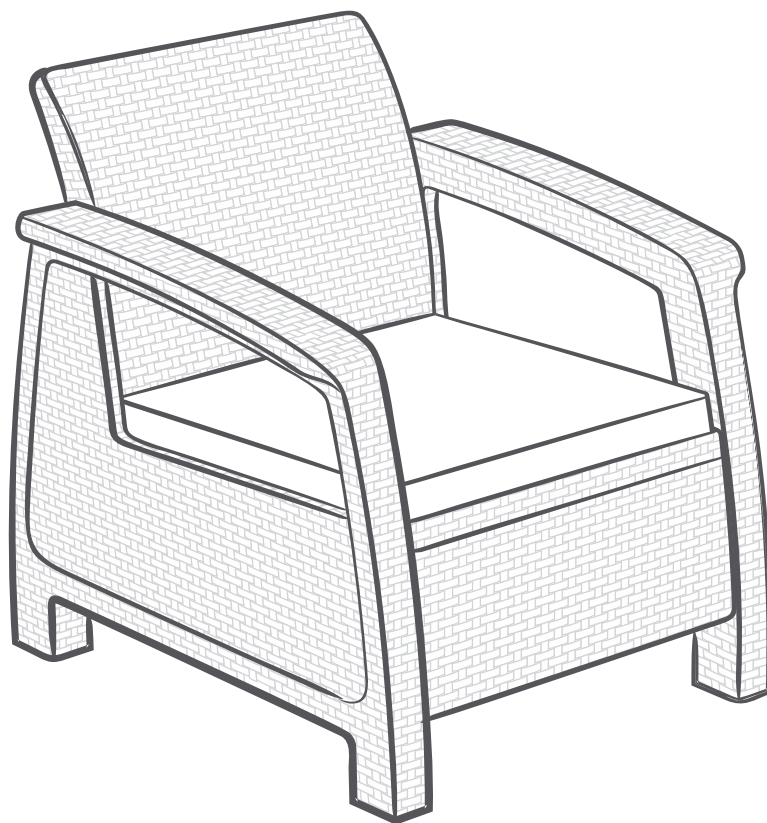



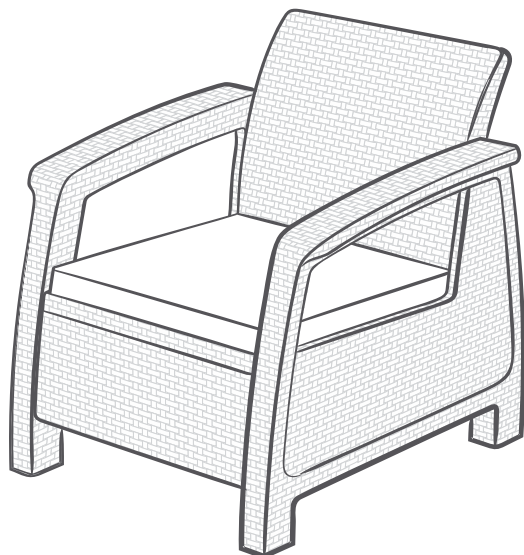

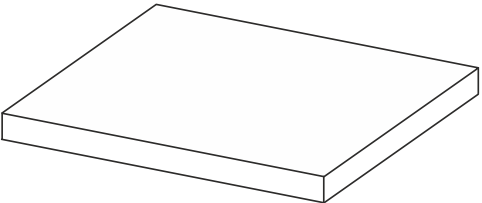
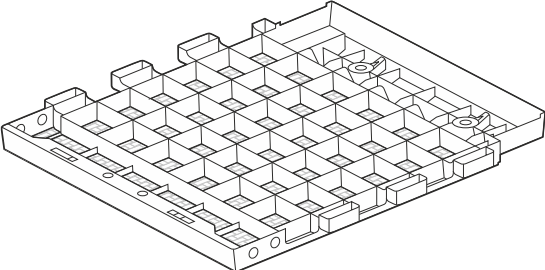
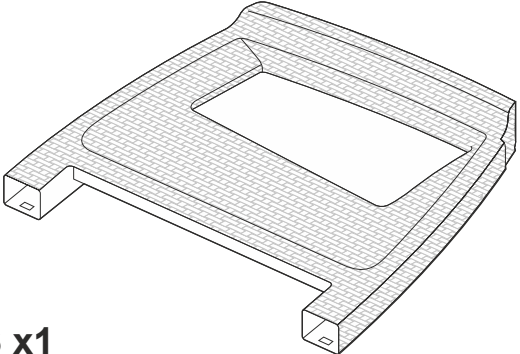
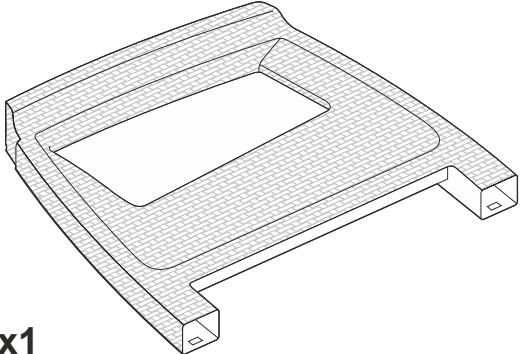
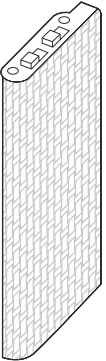
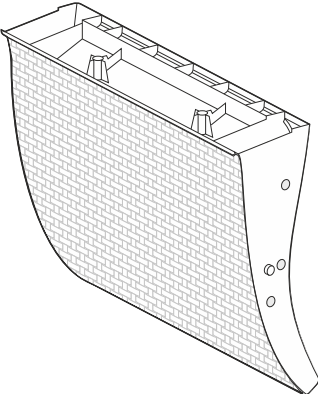

Assembly Instructions | Montageanleitung | Instrukcja montażu |
Összeszerelési útmutató | Руководство пользователя |
Інструкція з монтажу | Návod k montáži | Návod na montáž |
Instrucțiuni de montare



Important! Retain for future reference. | Wichtig! Bewahren Sie es bitte sicher auf. | Ważne! Proponujemy zachować. | Fontos! Ajánlott megőrizni. | Внимание! Рекомендуется сохранить. | Увага! Рекомендується зберегти. | Důležité! Doporučuje se uchovat. | Dôležité! Odporúča sa uchovať. | Important! Este recomandat să păstrați.



Contents | Inhalt | Zawartość | Tartalom | Содержание | Комплектація | Obsah | Obsah |

 <p>x1</p>	 <p>S x1</p>								
 <p>LS x1</p>	 <p>RS x1</p>								
 <p>FB x2</p>	 <p>B x1</p>								
 <p>L1 x1</p>	 <p>L2 x1</p>	 <p>L3 x1</p>	 <p>L4 x1</p>	 <p>x16</p>	 <p>LP x4</p>	 <p>SP x12</p>	 <p>L x1</p>	 <p>R x1</p>	

1

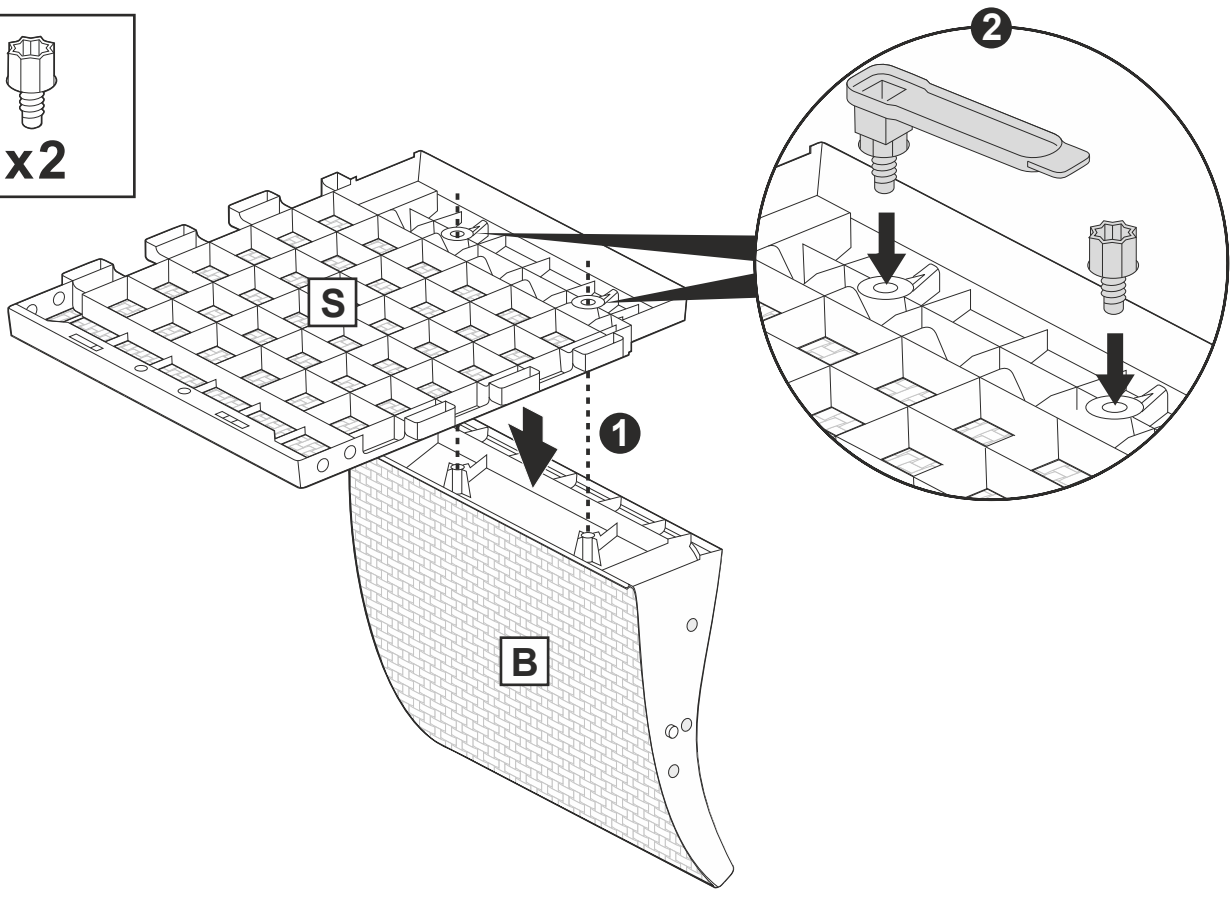
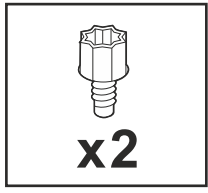

2

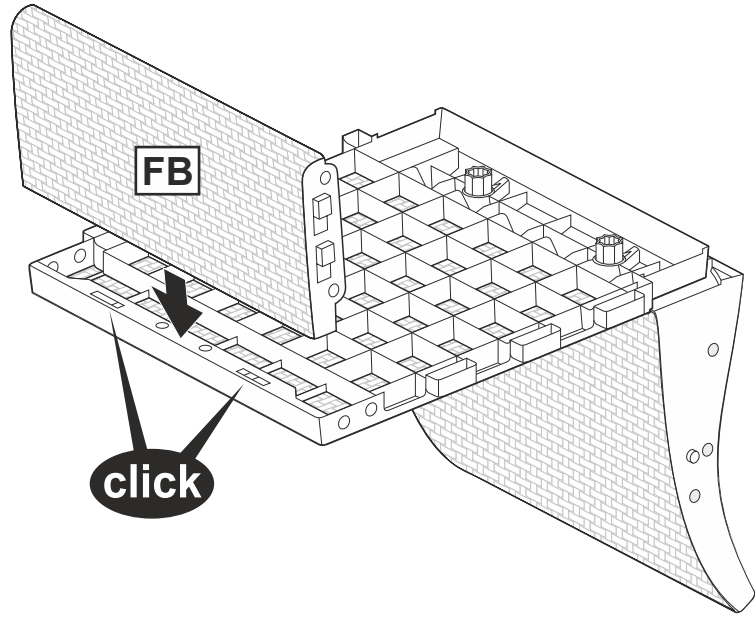

3

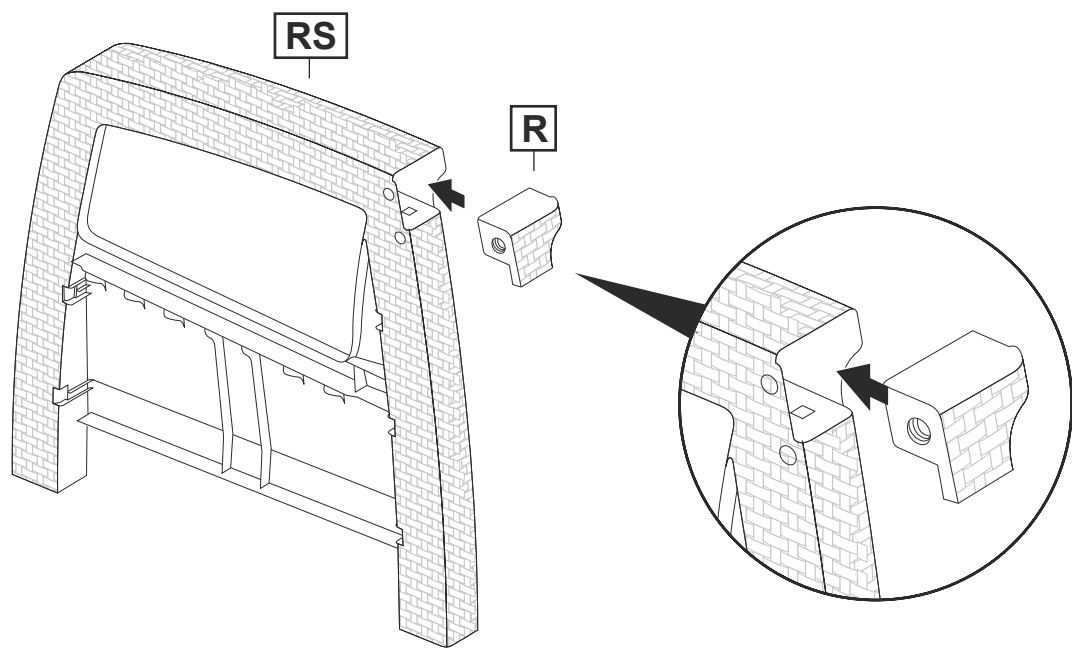

4

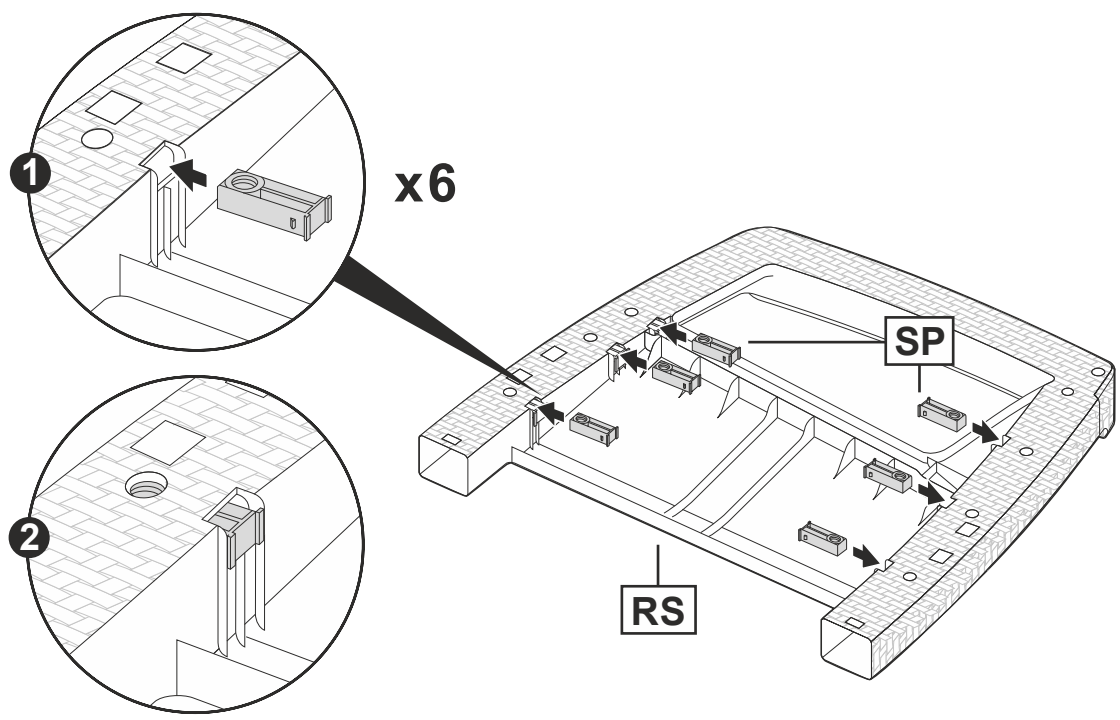
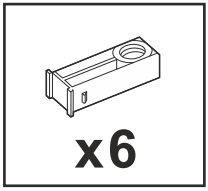

5

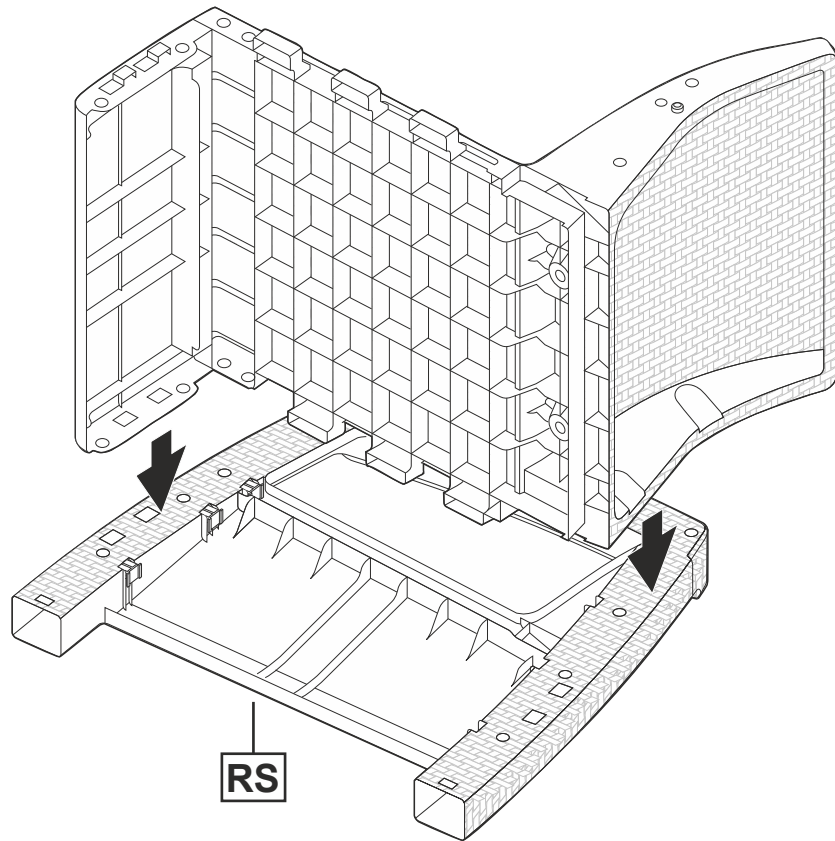

6

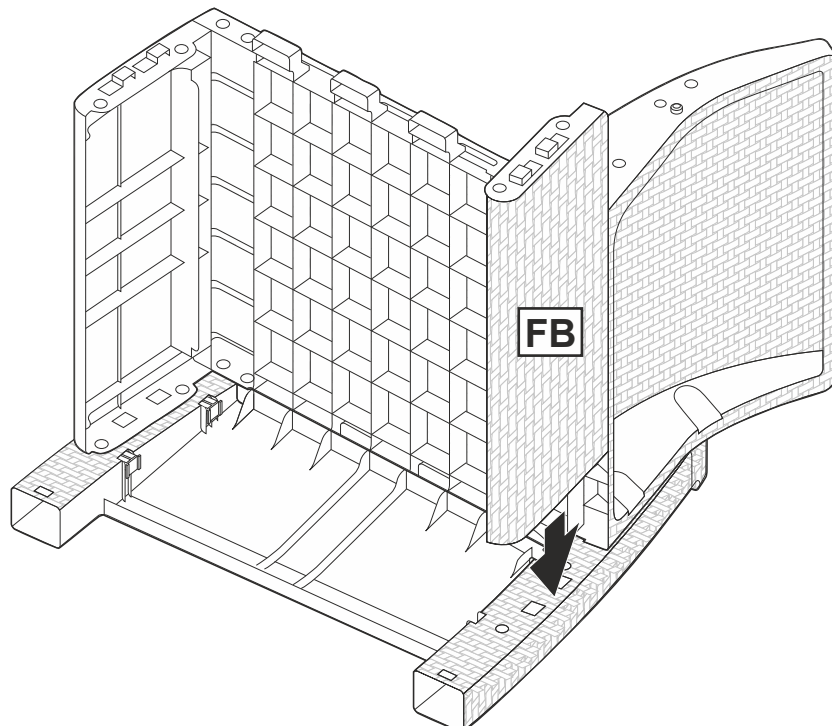

7

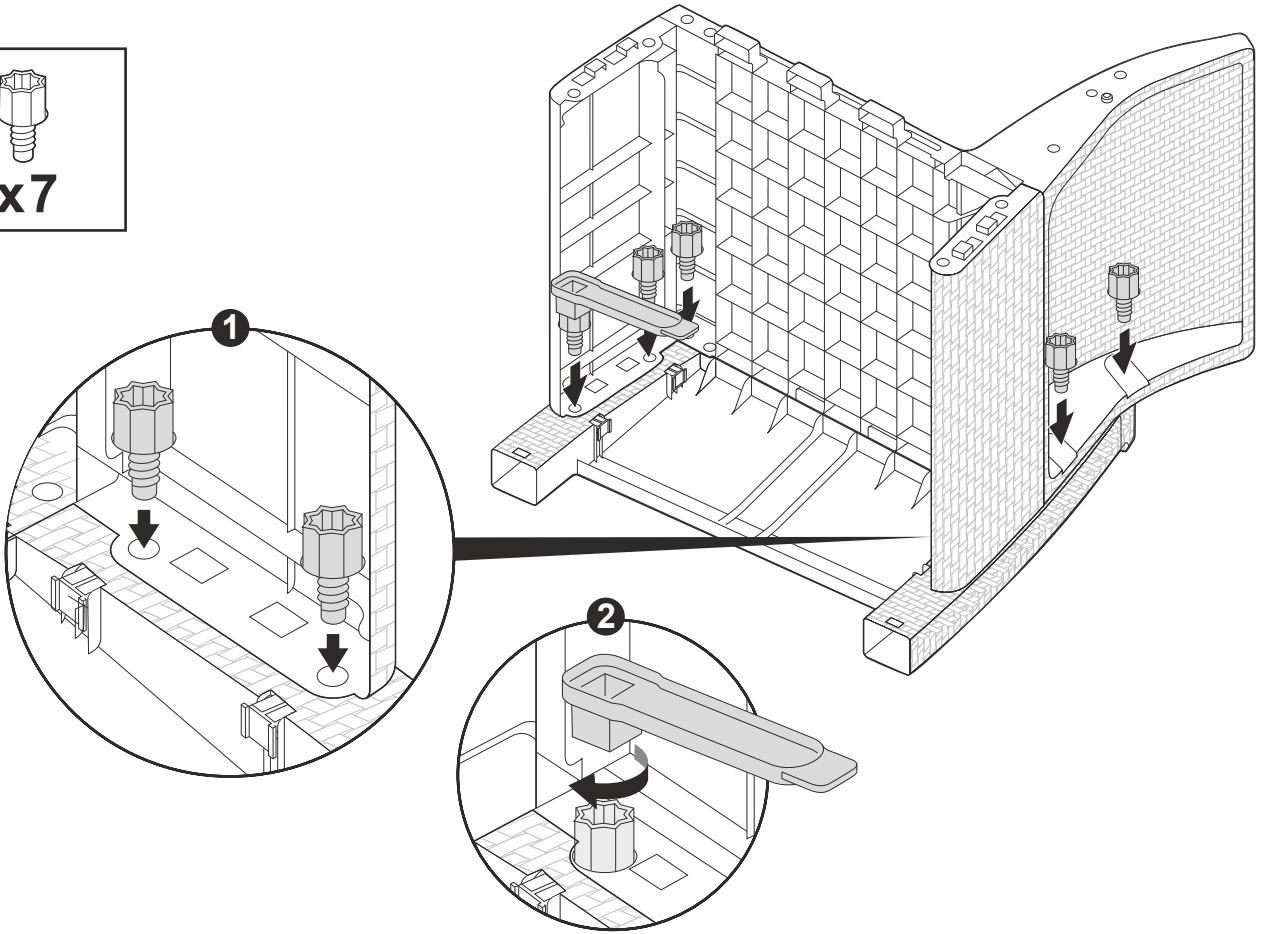
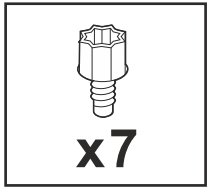

8

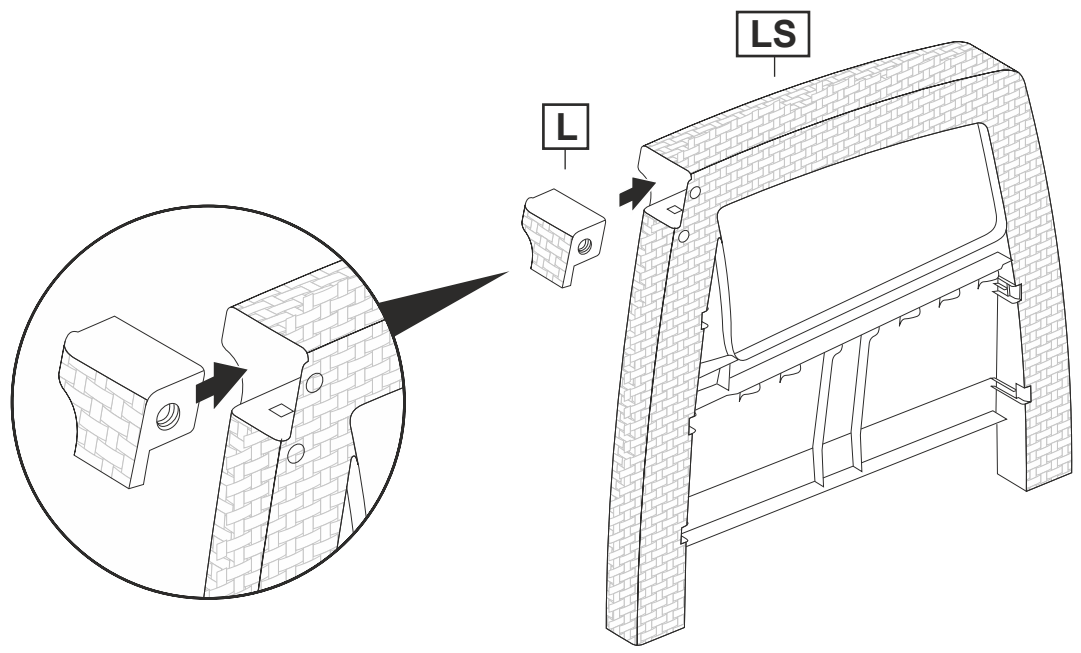

9

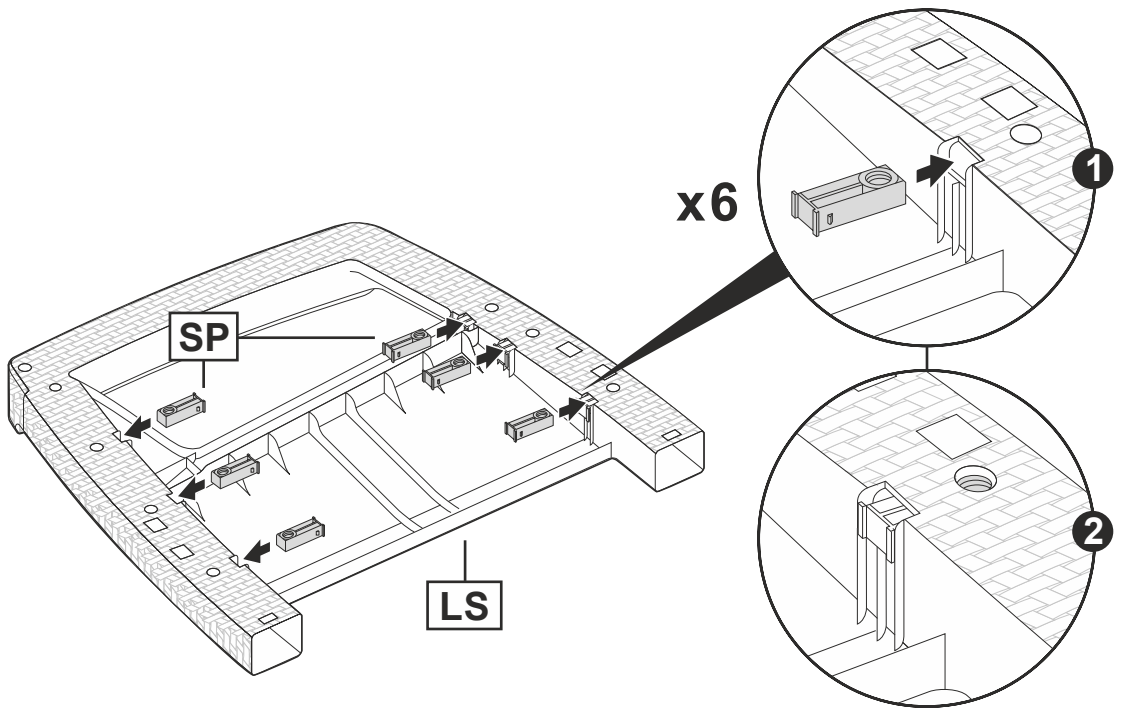
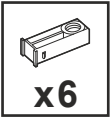

10

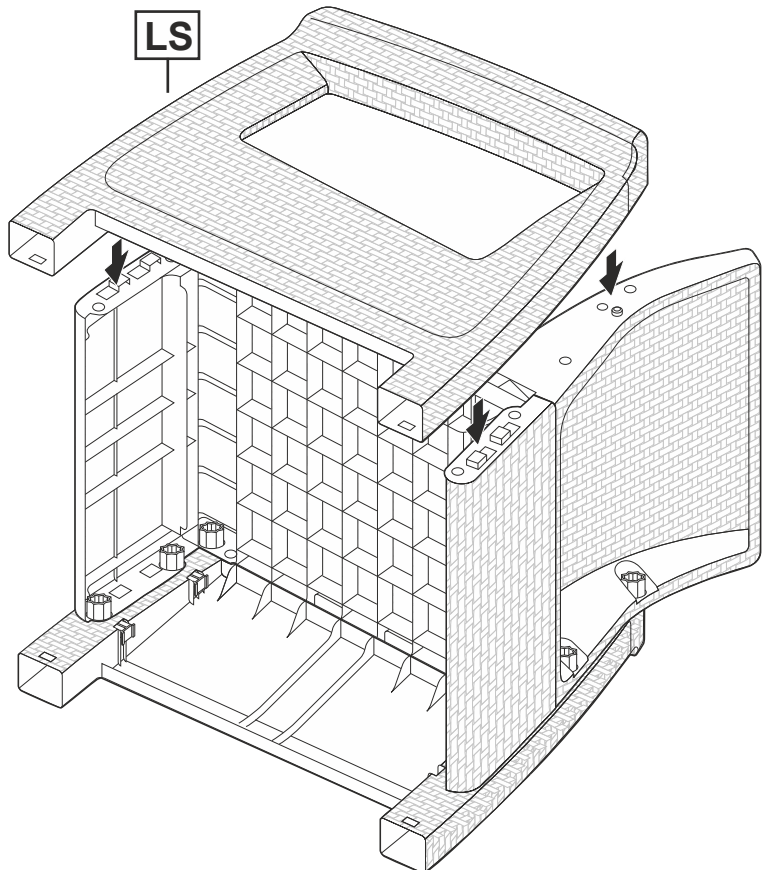
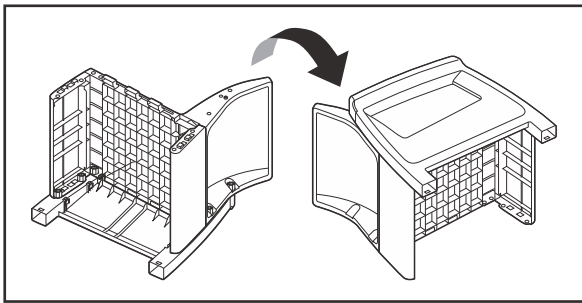

11

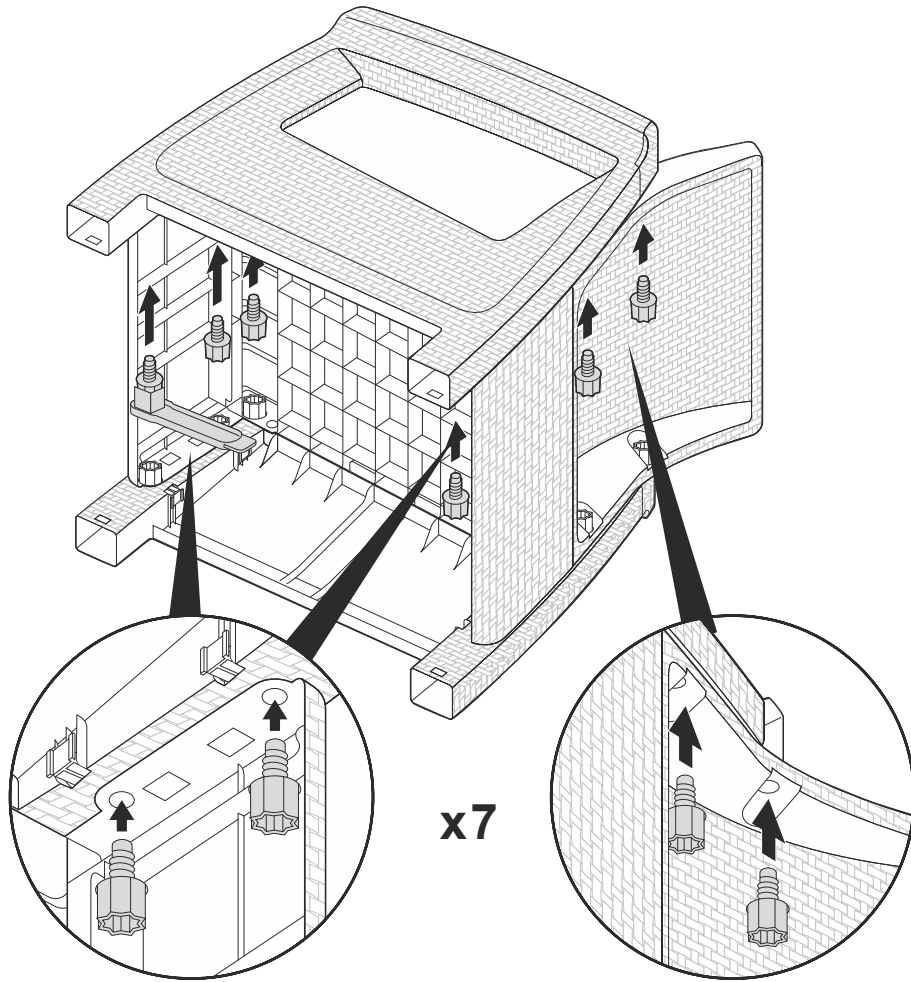

12

