

PROLYRON SET KERTI BÚTOR GARNITÚRA

SZERELÉSI ÚTMUTATÓ

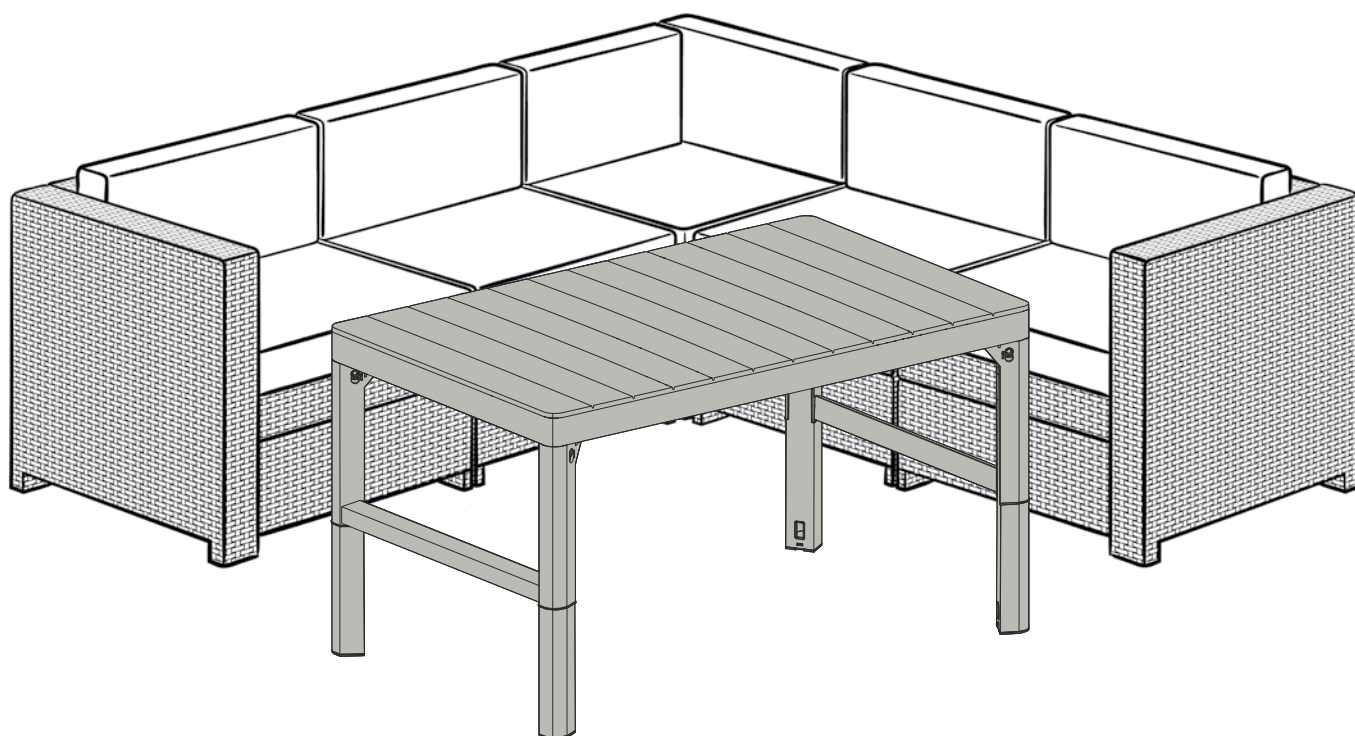

Notes and Warnings – Please Read Carefully Prior to Assembly
Notes et avertissements – Veuillez lire attentivement avant l'assemblage
Anmerkungen und Warnhinweise – Bitte sorgfältig vor der Montage lesen
Σημειώσεις και Προειδοποιήσεις – Διαβάστε προσεκτικά πριν τη συναρμολόγηση
Opmerkingen en waarschuwingen – Voor het monteren aandachtig doorlezen
Notas y advertencias: lea con atención antes de armar ☒
Megjegyzések,figyelmeztetések

EN

- Please assemble each piece of furniture on a flat surface.
- A dedicated wrench is enclosed for assembly.
- Only a standard Phillips screwdriver is required in addition to this wrench.
- It is recommended to assemble the screws and nuts manually, and only tighten them with the enclosed wrench at the end of the assembly process.
- It is highly recommended that you retain the wrench for future use.
- The pieces of furniture should only be cleaned using soap, water, and a soft cloth.
- The pieces of furniture are only intended for reasonable domestic use.

FR

- Veuillez assembler chaque meuble sur une surface plane.
- Une clef spéciale est incluse pour l'assemblage.
- Seul un tournevis standard Phillips est nécessaire en plus de cette clef.
- Il est recommandé d'assembler les vis et les écrous manuellement et de ne les serrer avec la clef fournie qu'à la fin du processus d'assemblage.
- Il est vivement recommandé de conserver la clef pour une utilisation future.
- Les meubles doivent être nettoyés au savon et à l'eau uniquement, et à l'aide d'un chiffon doux.
- Les meubles sont destinés à un usage domestique raisonnable.

DE

- Bitte montieren Sie jedes Möbelstück auf einer glatten Fläche.
- Ein zur Montage geeigneter Sechskantschlüssel ist beige gefügt.
- Zusätzlich zu dem Sechskantschlüssel wird noch ein normaler Kreuzschraubendreher benötigt.
- Es wird empfohlen, alle Schrauben und Muttern per Hand einzudrehen und diese erst nach Beendigung des Zusammenbaus mit dem Sechskantschlüssel festzuziehen.
- Bewahren Sie den Sechskantschlüssel für einen zukünftigen Gebrauch auf.
- Zur Reinigung der Möbelstücke sind nur Seifenlauge, Wasser und ein weiches Tuch zu verwenden.
- Die Möbelstücke sind nur zur angemessenen privaten Nutzung ausgelegt.

EL

- Συναρμολογήστε κάθε τεμάχιο επίπλου σε επίπεδη επιφάνεια.
- Περιλαμβάνεται ειδικό μηχανικό κλειδί για τη συναρμολόγηση.
- Πέραν του συγκεκριμένου μηχανικού κλειδιού, απαιτείται ένα απλό κατσαβίδι Phillips.
- Προτείνεται να συναρμολογήσετε τις βίδες και τα παξιμάδια με το χέρι, και να τα σφίξετε με το μηχανικό κλειδί που περιλαμβάνεται, στο τέλος της διαδικασίας συναρμολόγησης.
- Σας συμβουλεύουμε να φυλάξετε το μηχανικό κλειδί για μελλοντική χρήση.
- Τα τεμάχια επίπλων πρέπει να καθαρίζονται χρησιμοποιώντας μόνο σαπούνι και νερό, με τη βοήθεια μαλακού υφάσματος.
- Τα τεμάχια επίπλων προορίζονται μόνο για εύλογη οικιακή χρήση.

NL

- Monteer elke meubelstuk op een vlakke ondergrond.
- Voor de montage is een passende sleutel bijgesloten.
- Behalve deze sleutel hebt u ook een standaard kruisschroevendraaier nodig.
- Het wordt aangeraden om de schroeven en moeren handmatig vast te draaien en ze alleen aan het einde van de montageprocedure met de bijgesloten sleutel vast te zetten.
- Het wordt aangeraden dat u de sleutel voor toekomstig gebruik bewaard.
- De meubels mogen alleen met zeep, water en een zachte doek worden gereinigd.

HU

- Kérjük, állítsa össze az összes bútordarabot sík felületre.
- Az összeszereléshez külön csavarkulcs van mellékelve.
- Ezen a kulcson kívül csak egy szabványos Phillips csavarhúzóra van szükség.
- Javasoljuk, hogy a csavarokat és az anyákat kézzel szerelje össze, és csak az összeszerelés végén húzza meg őket a mellékelt kulccsal.
- Javasoljuk, hogy a csavarkulcsot későbbi felhasználás céljából őrizze meg.
- A bútorokat csak szappannal, vízzel és puha ruhával szabad tisztítani.
- A bútorokat csak ésszerű háztartási használatra szánják.



<p>F x1</p>	<p>LS x1</p>	<p>SP x2</p>	<p>G x1</p>
<p>PR x1</p>	<p>BC x1</p>	<p>x4</p>	<p>x1</p>
<p>S x2</p>	<p>L x1</p>	<p>x1</p>	<p>x20</p>
<p>x1</p>	<p>x1</p>	<p>x18</p>	<p>x1</p>
<p>x1</p>	<p>x1</p>	<p>x1</p>	<p>x2</p>

F

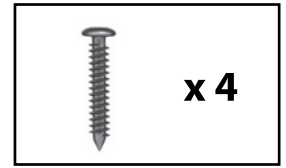
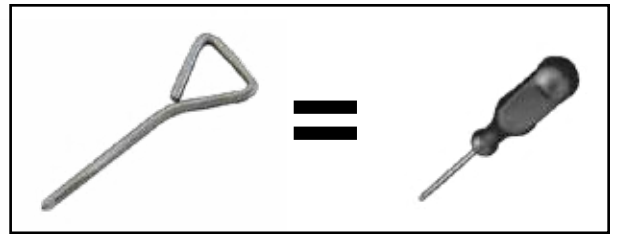
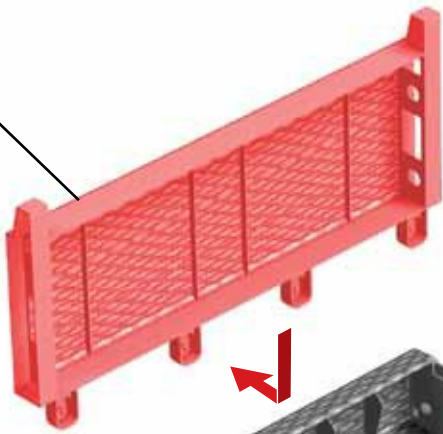

S



1

L

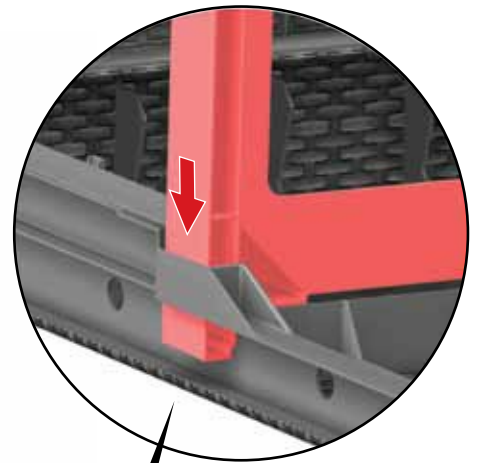
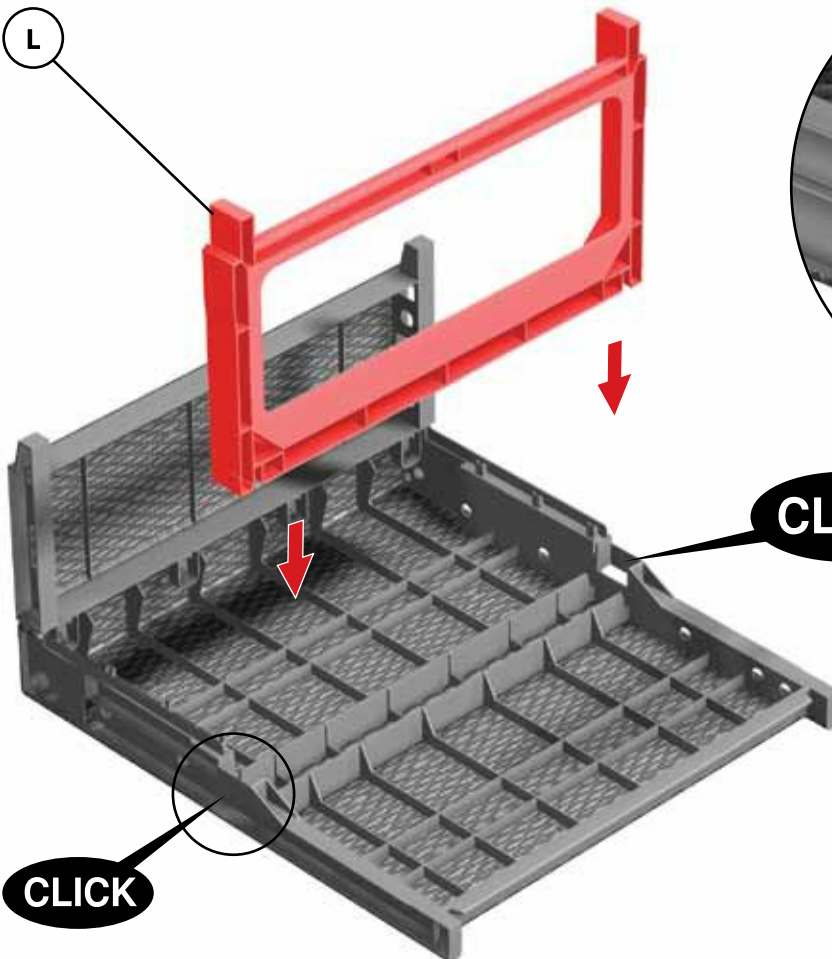

CLICK

CLICK

2

S

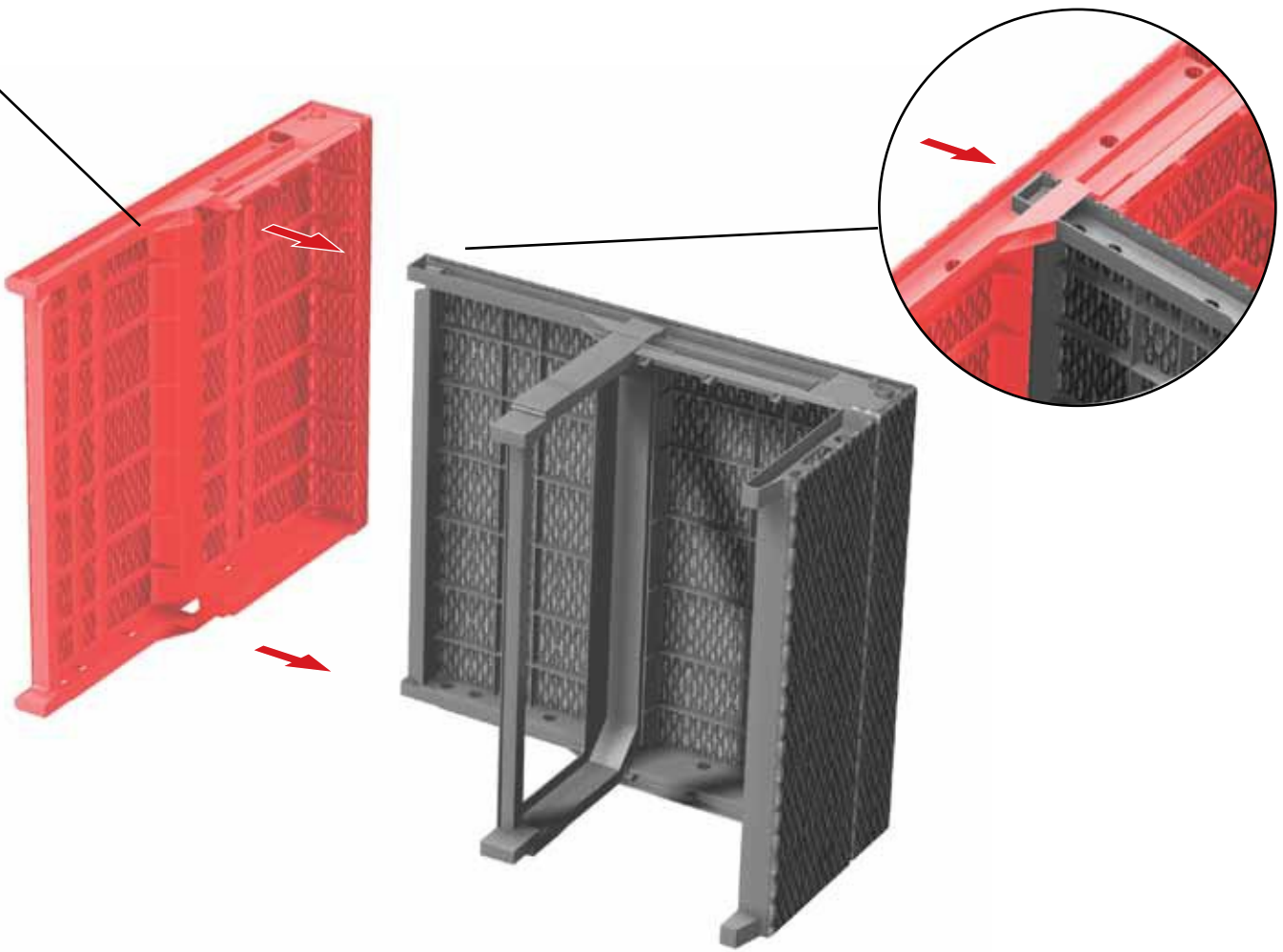

3

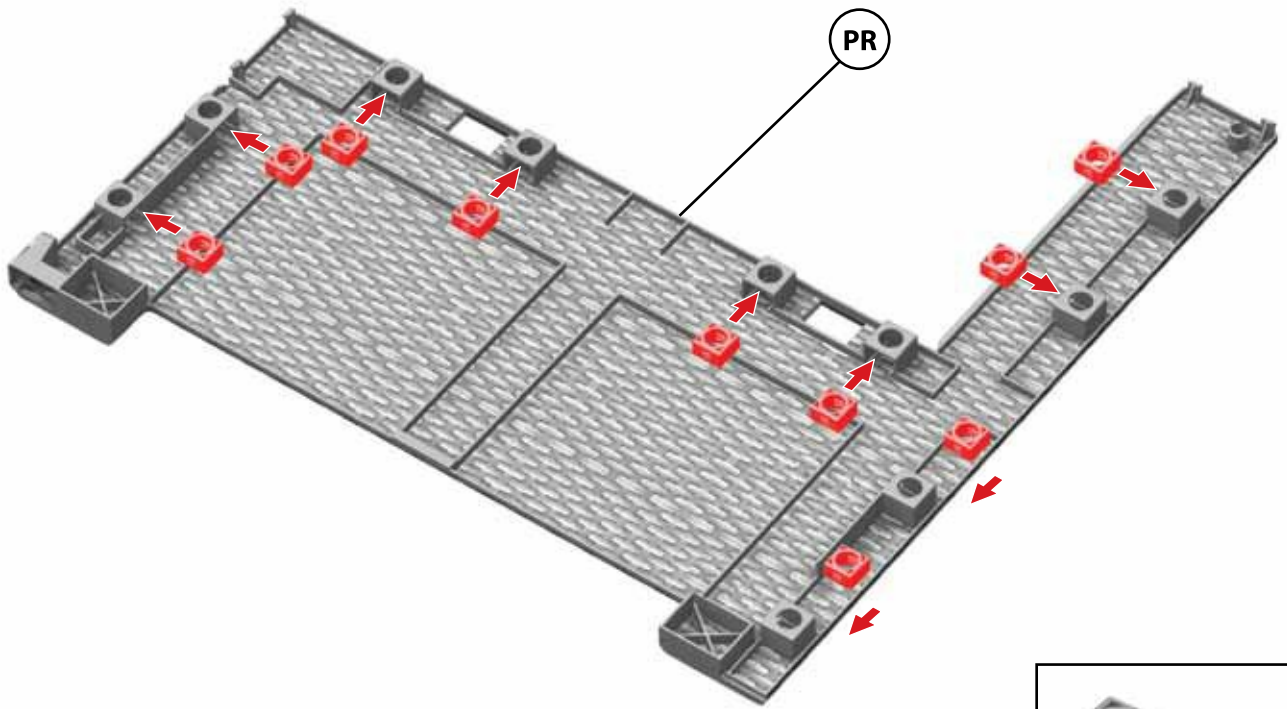

PR



4

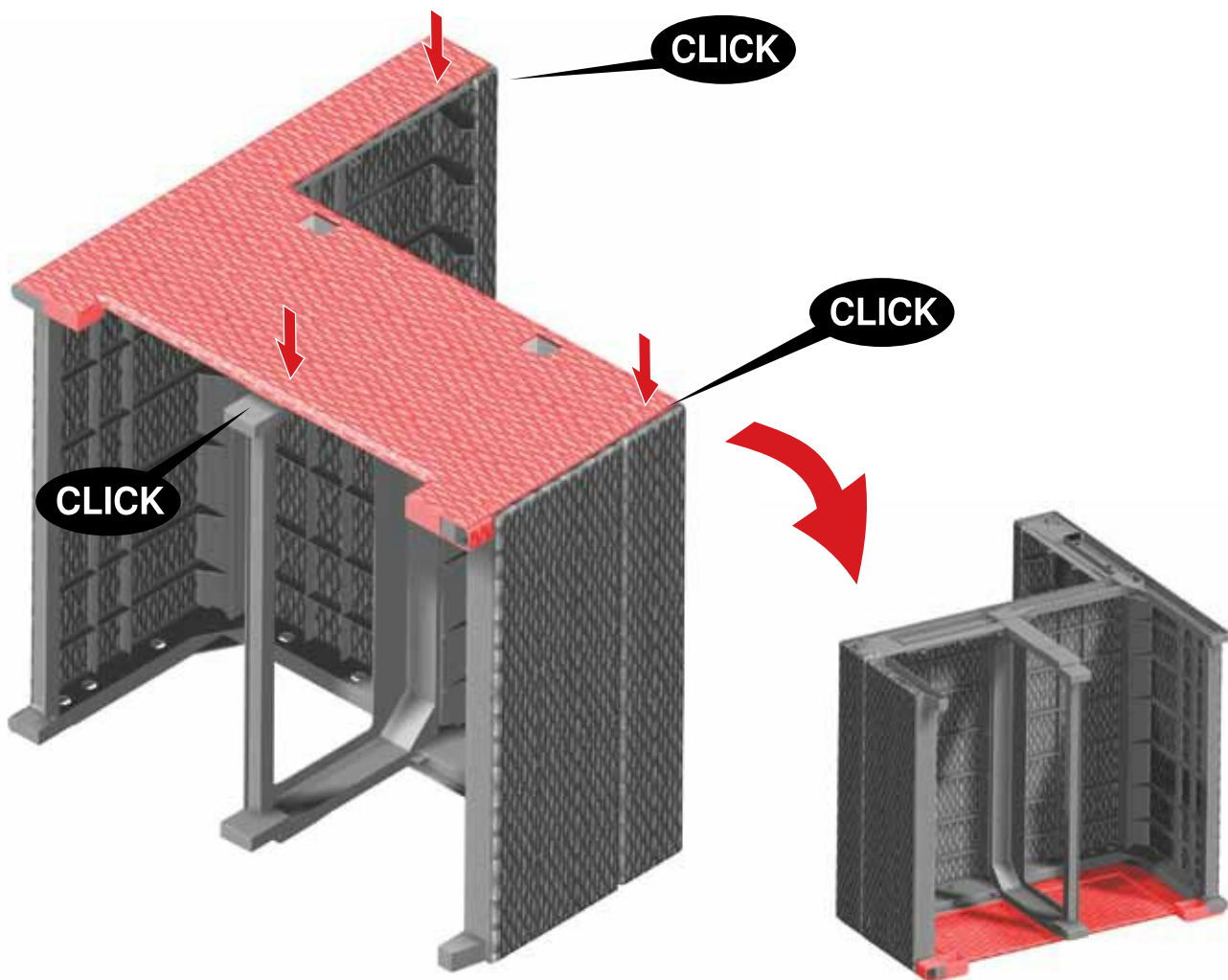
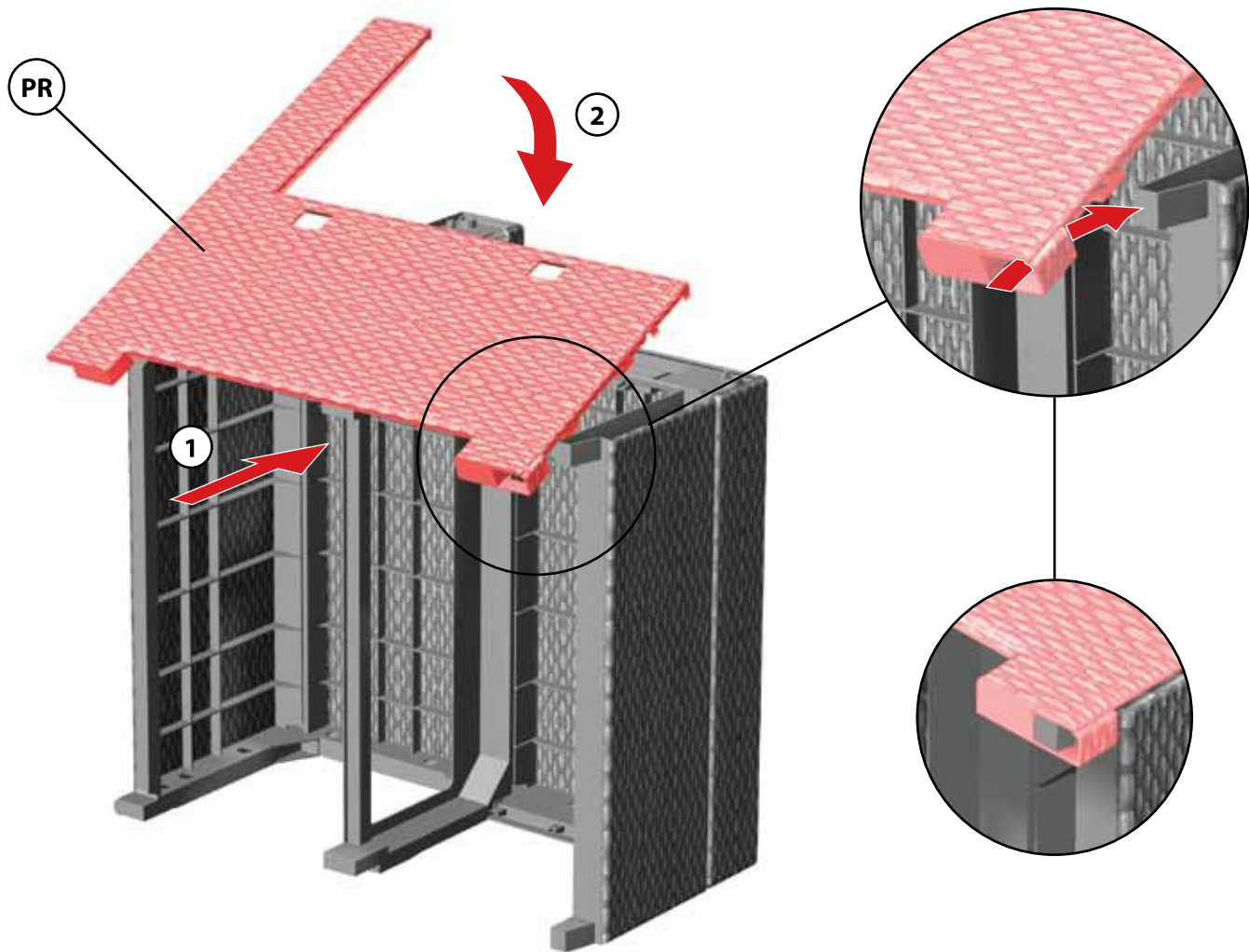

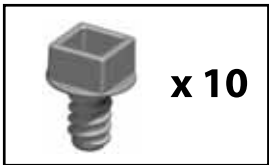
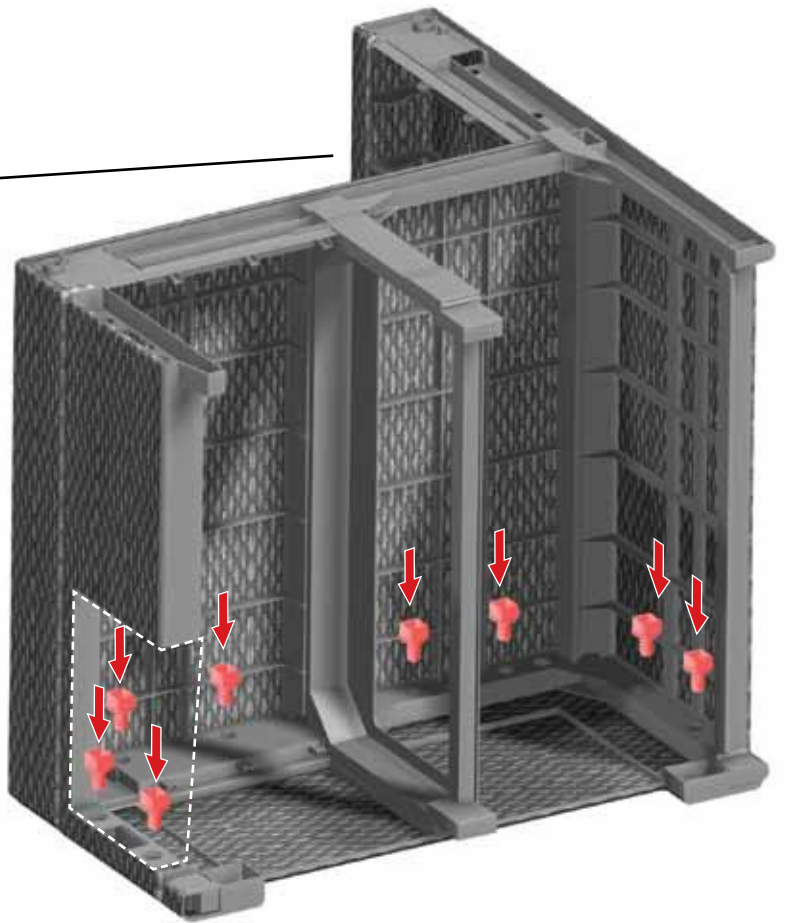
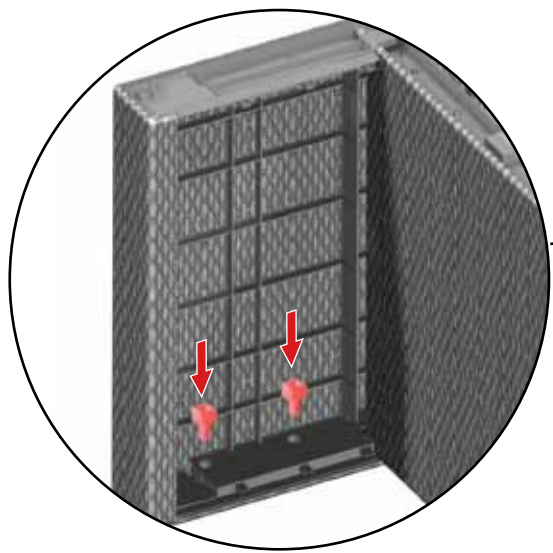

7

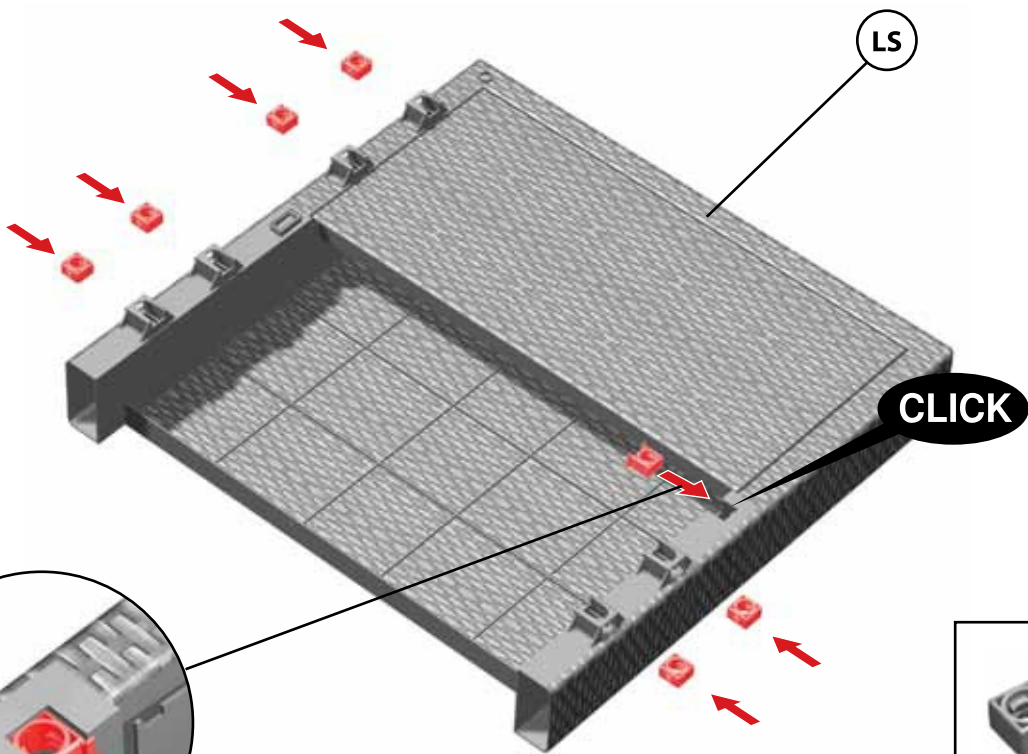

8

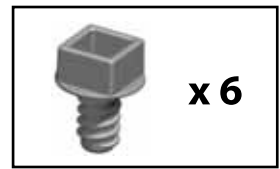
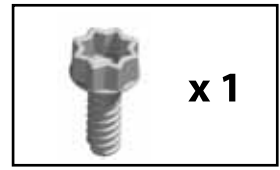
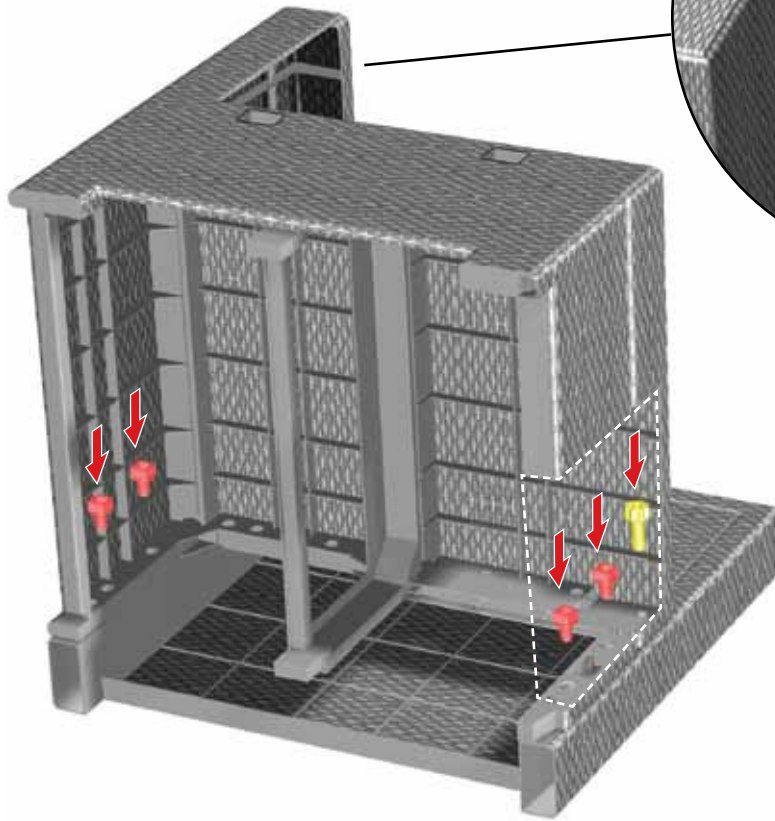
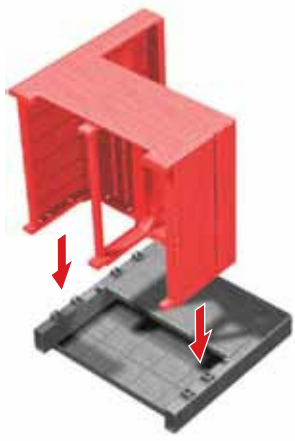

9

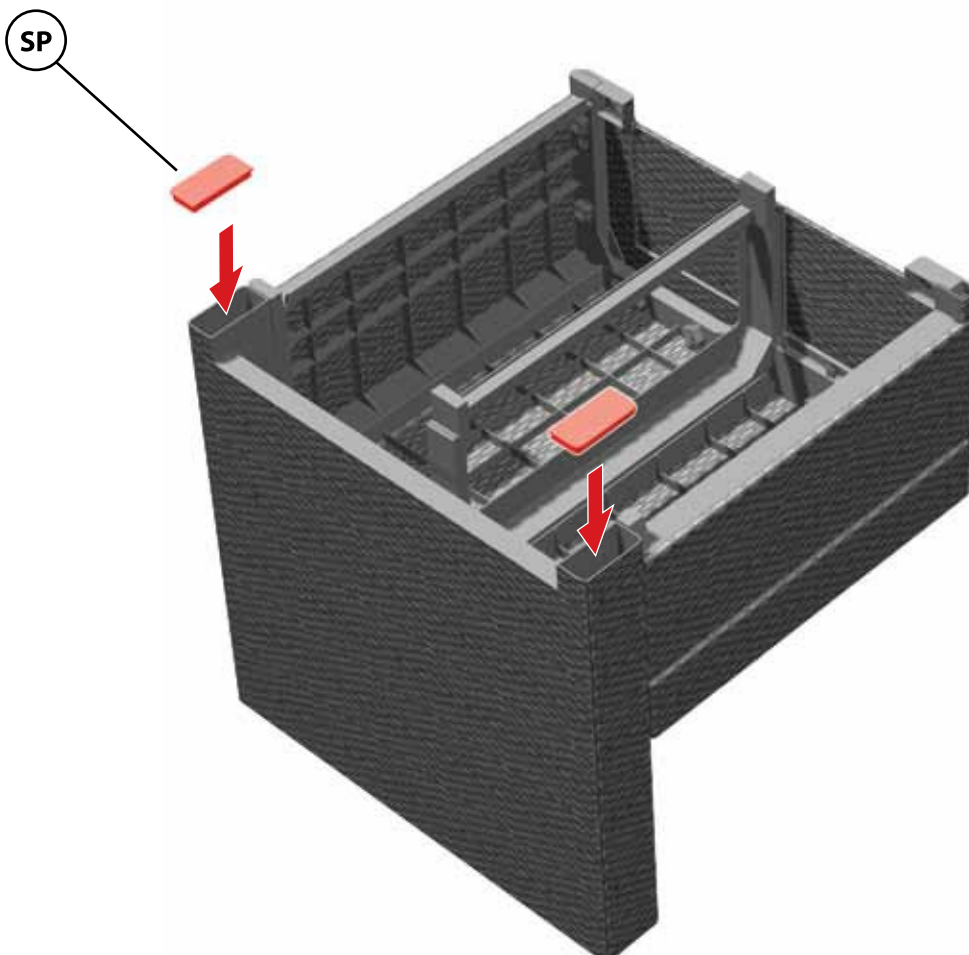

10

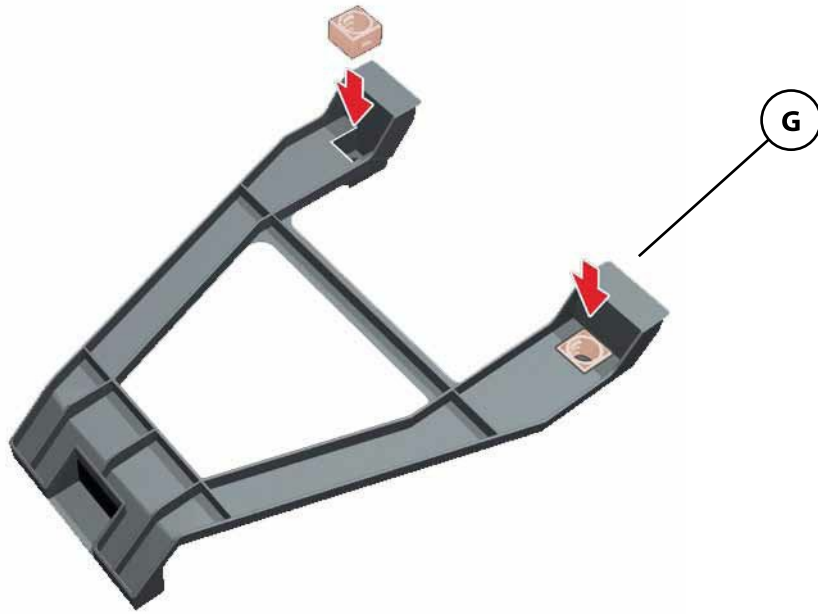
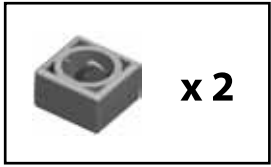

11

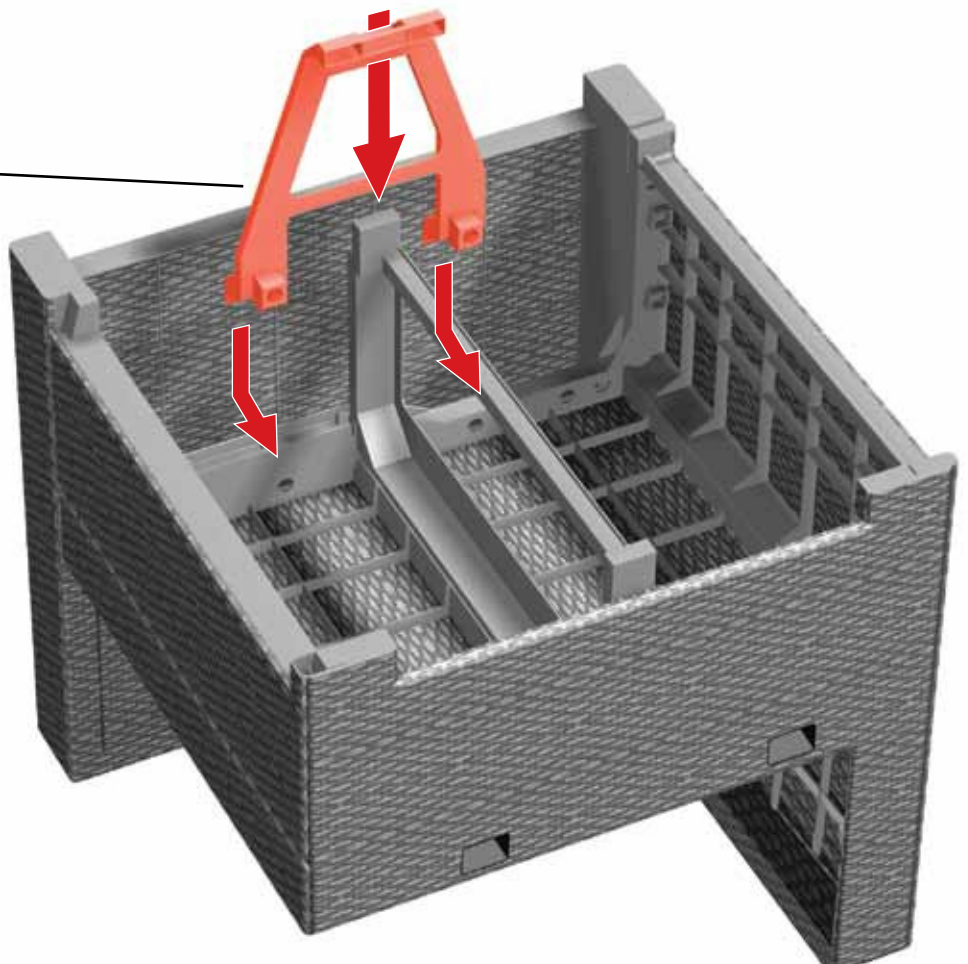

12

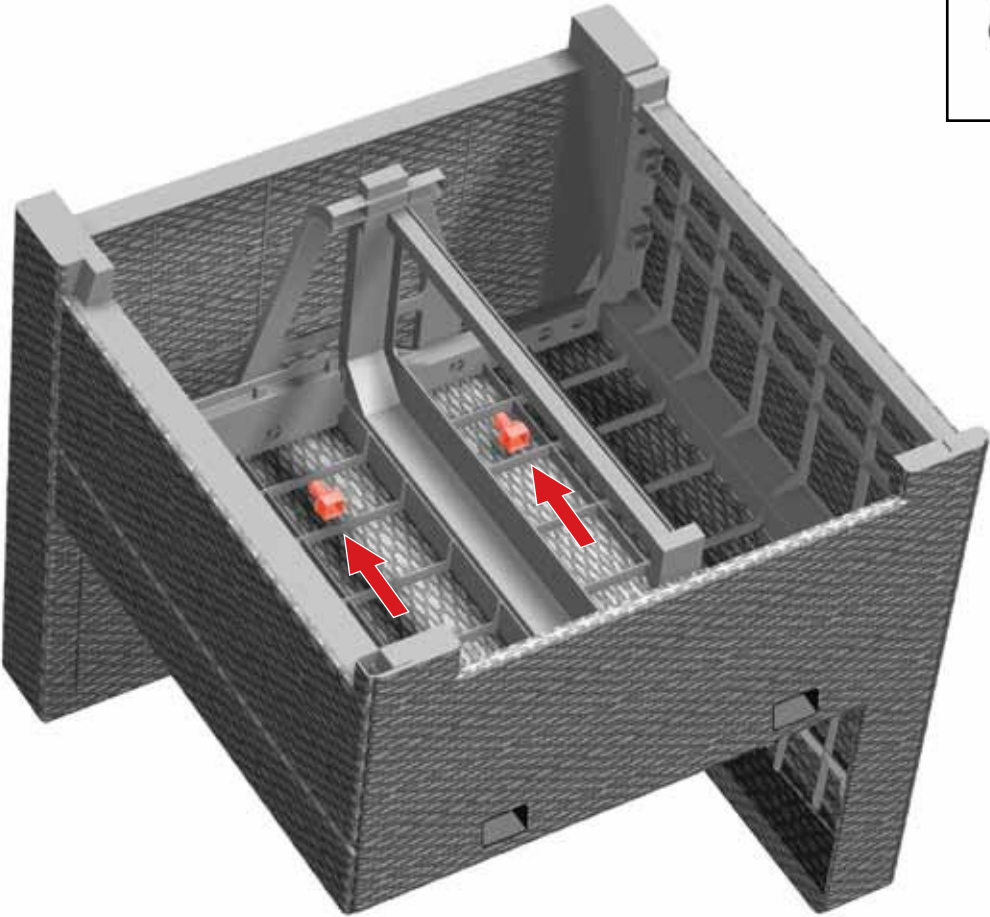

13

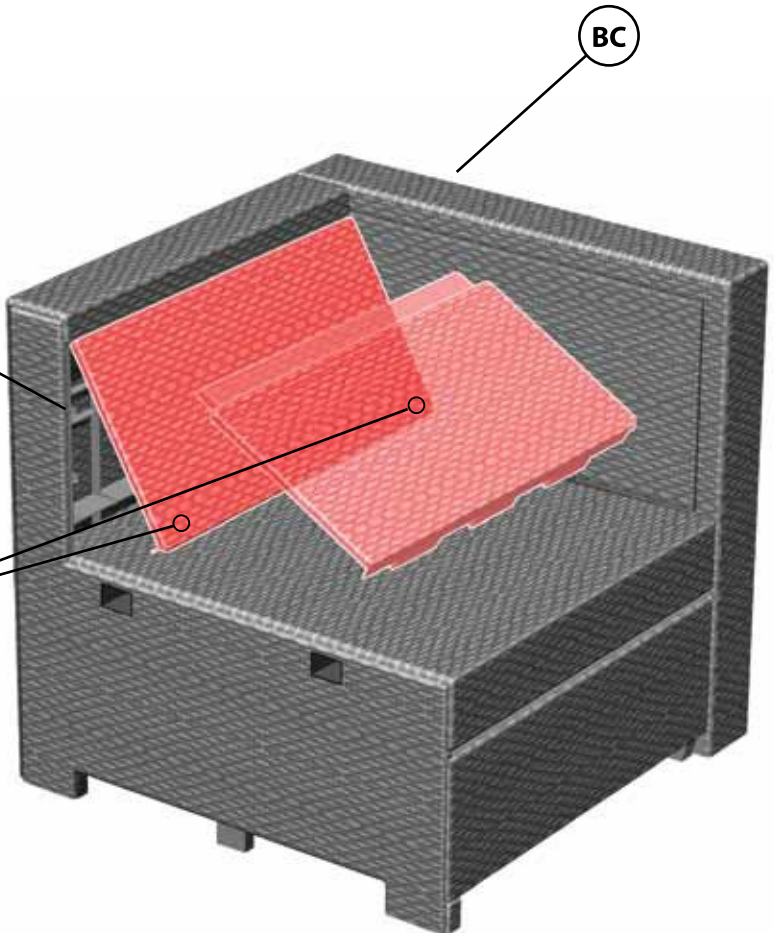
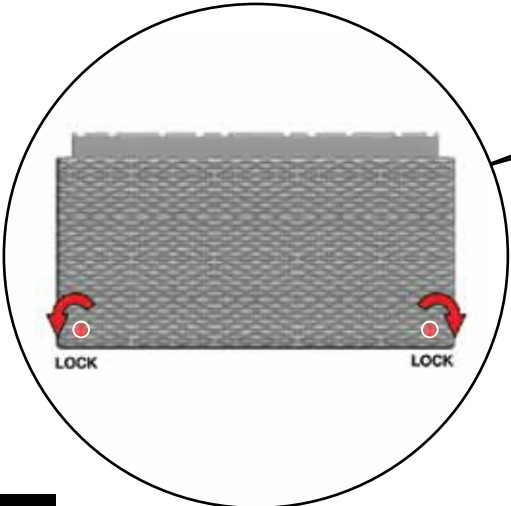
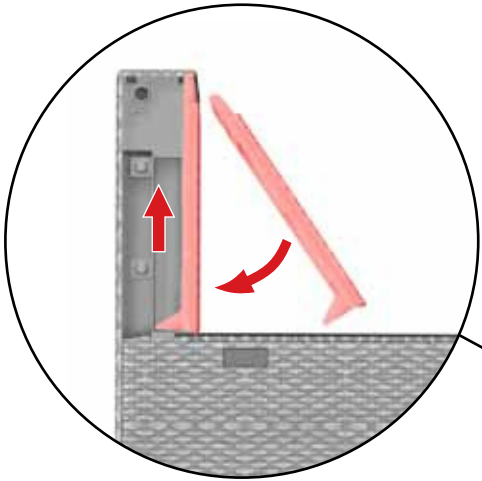

14

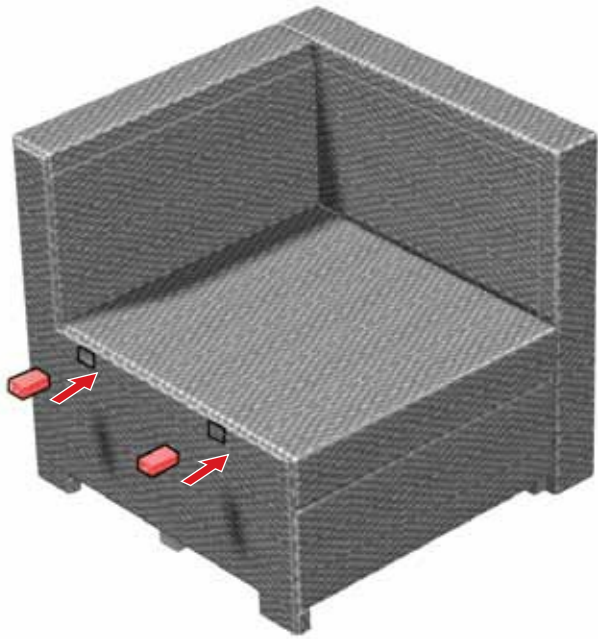

1

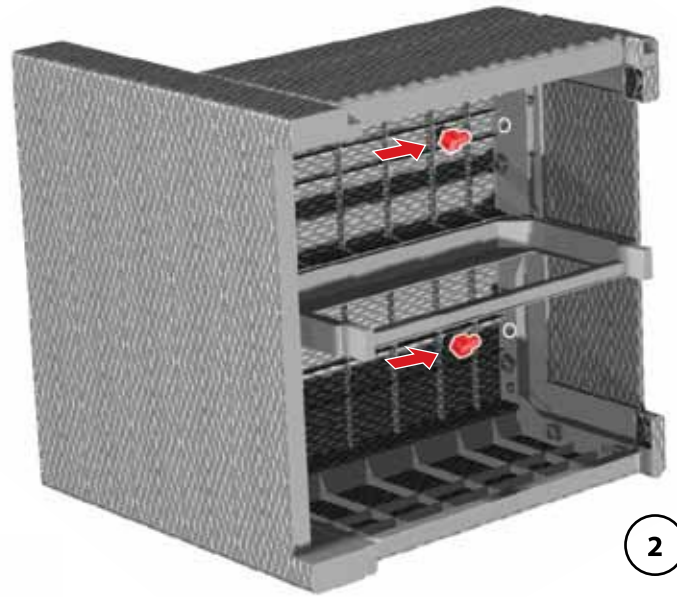
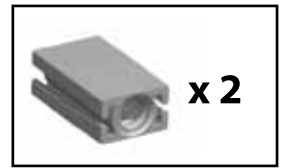
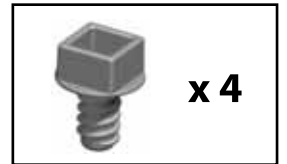

2

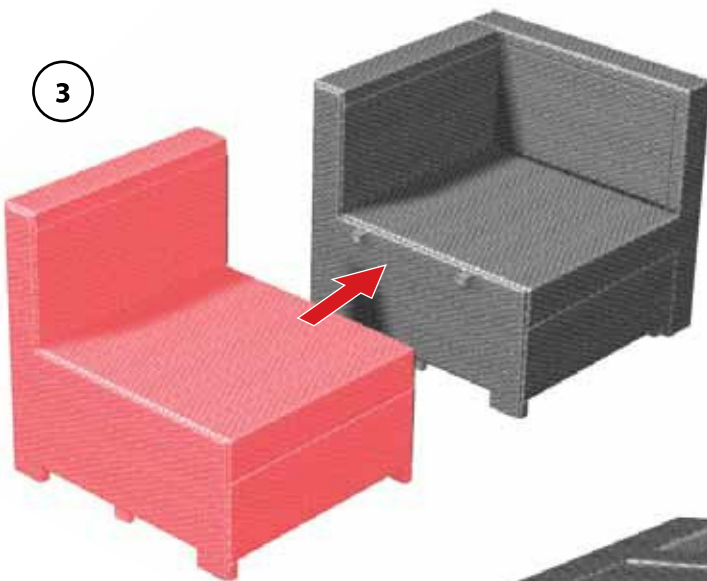

3

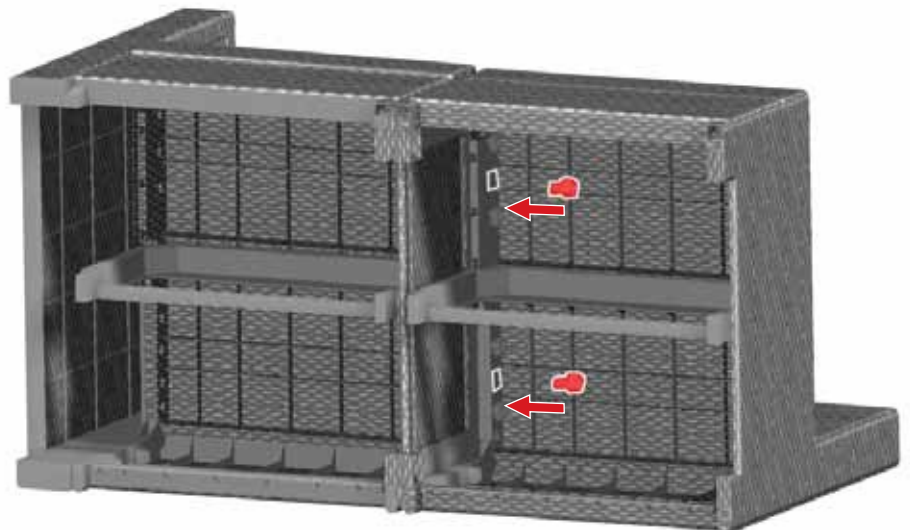

4

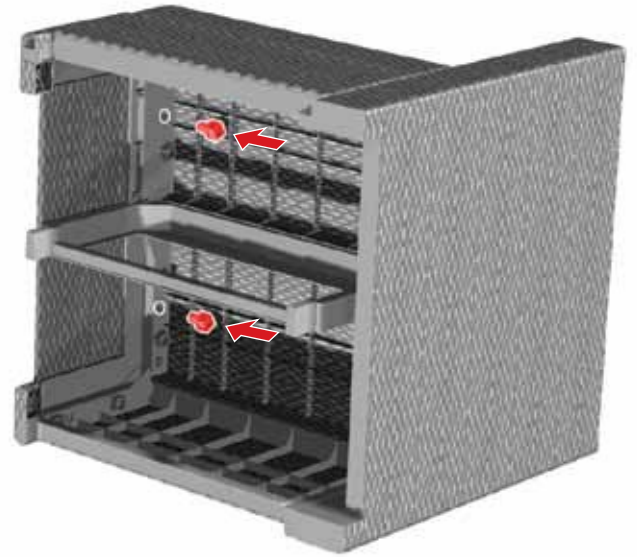
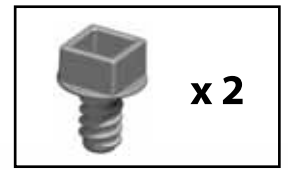
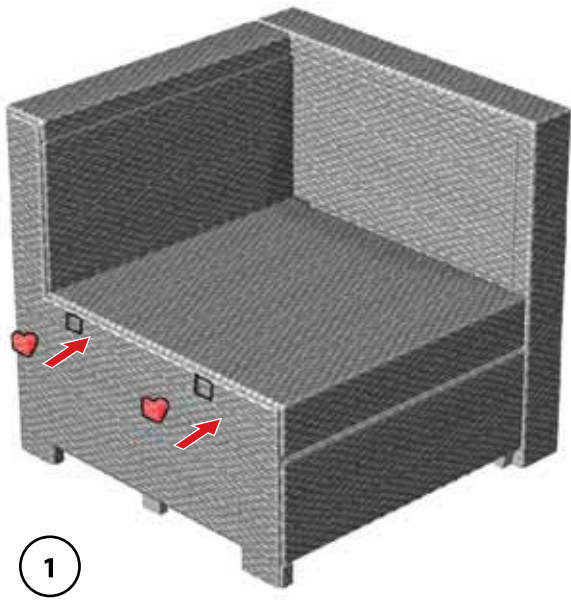



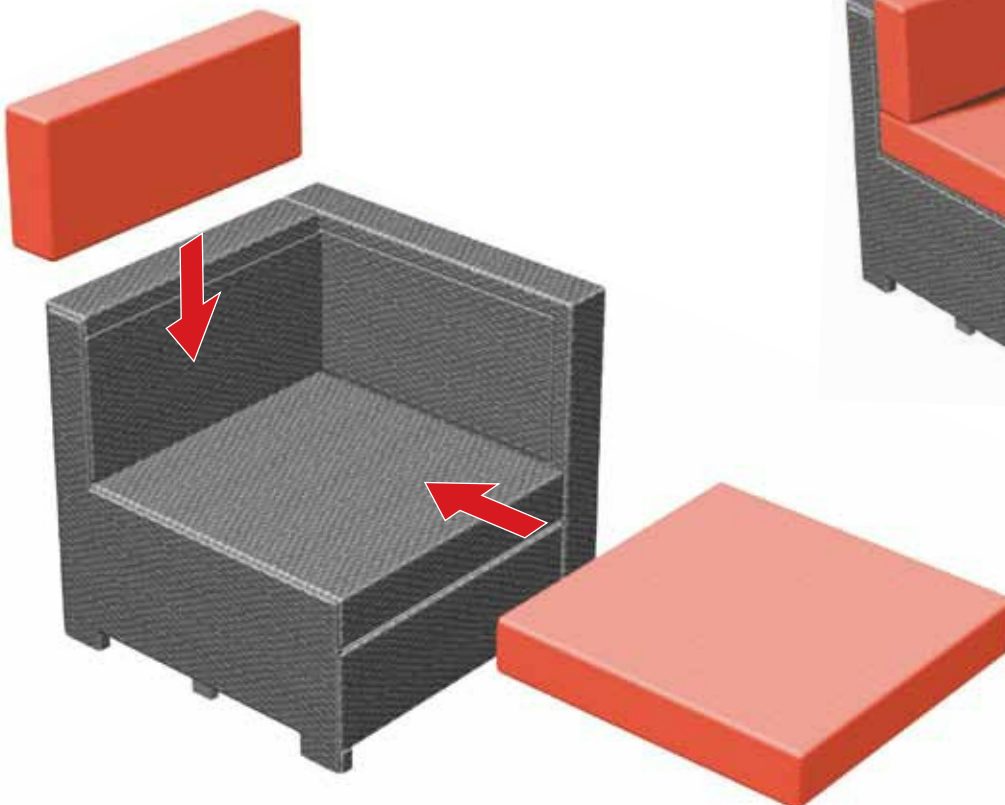





15B

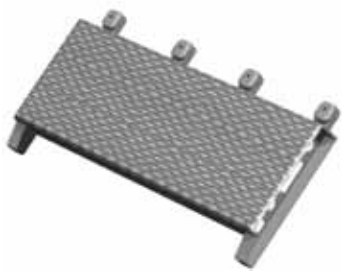
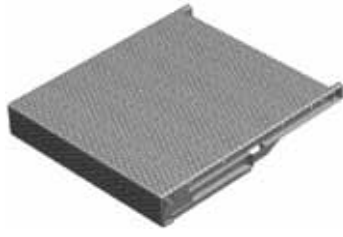

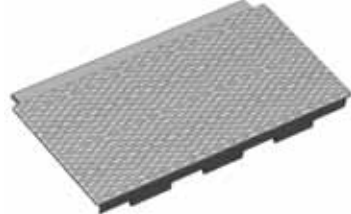
16

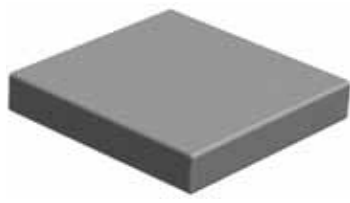
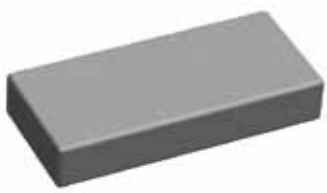
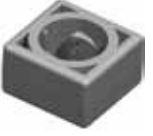

X2

 <p>F x1</p>	 <p>S x2</p>	 <p>x4</p>
 <p>PR x1</p>	 <p>BC x1</p>	 <p>x1</p>
 <p>PL x1</p>	 <p>L x1</p>	 <p>x24</p>
 <p>x1</p>	 <p>x1</p>	 <p>x20</p>
		 <p>x4</p>
		 <p>x2</p>

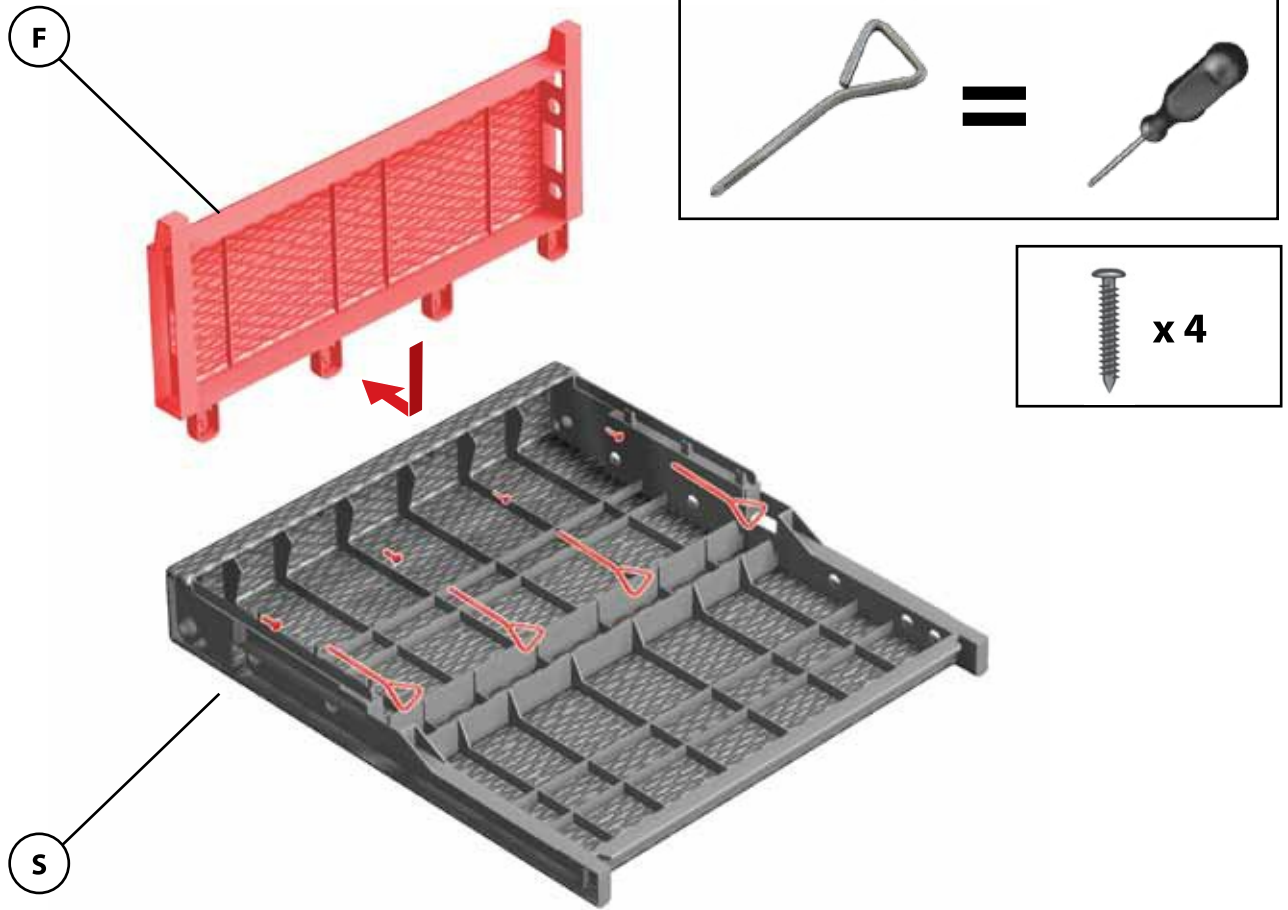

1

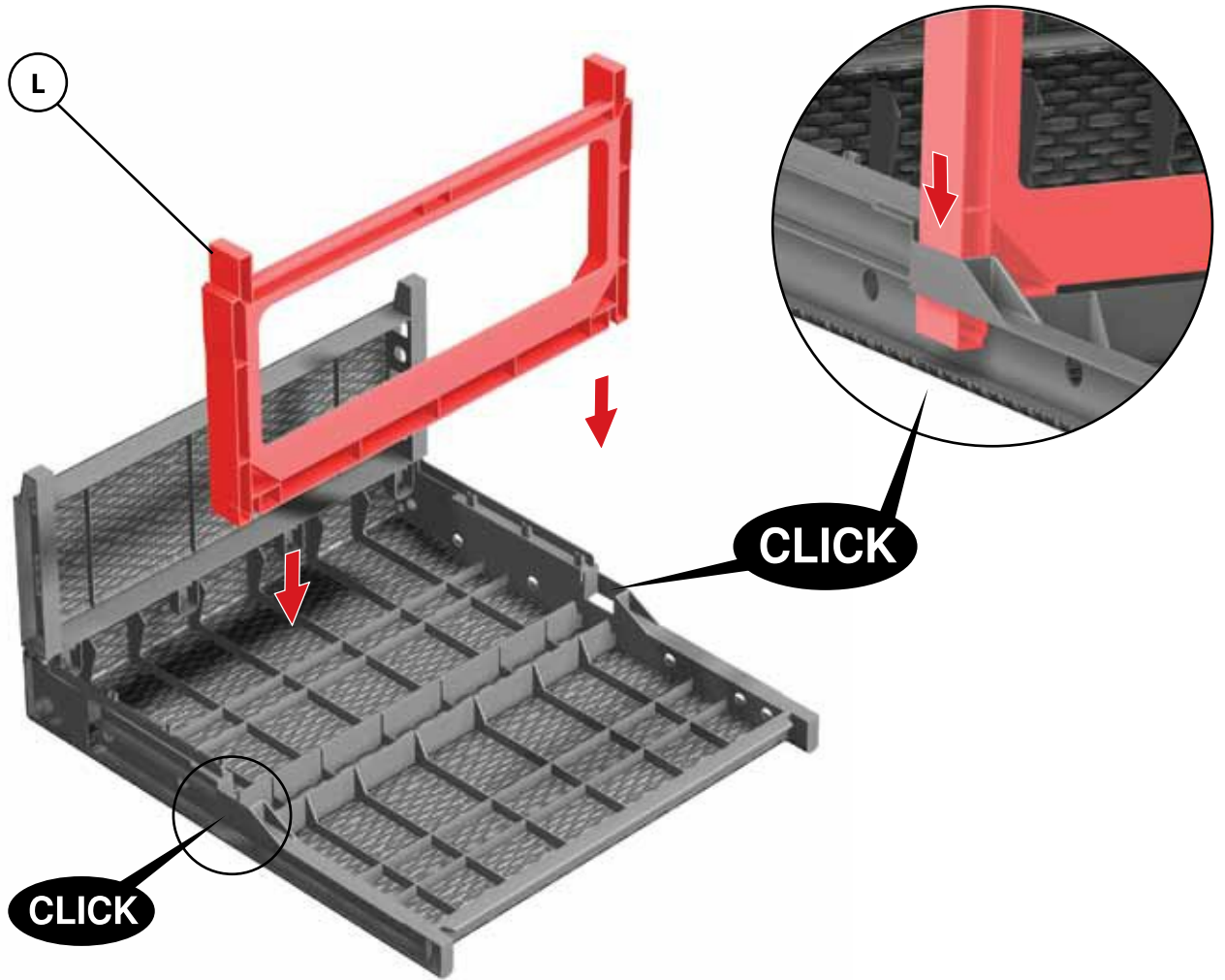

2

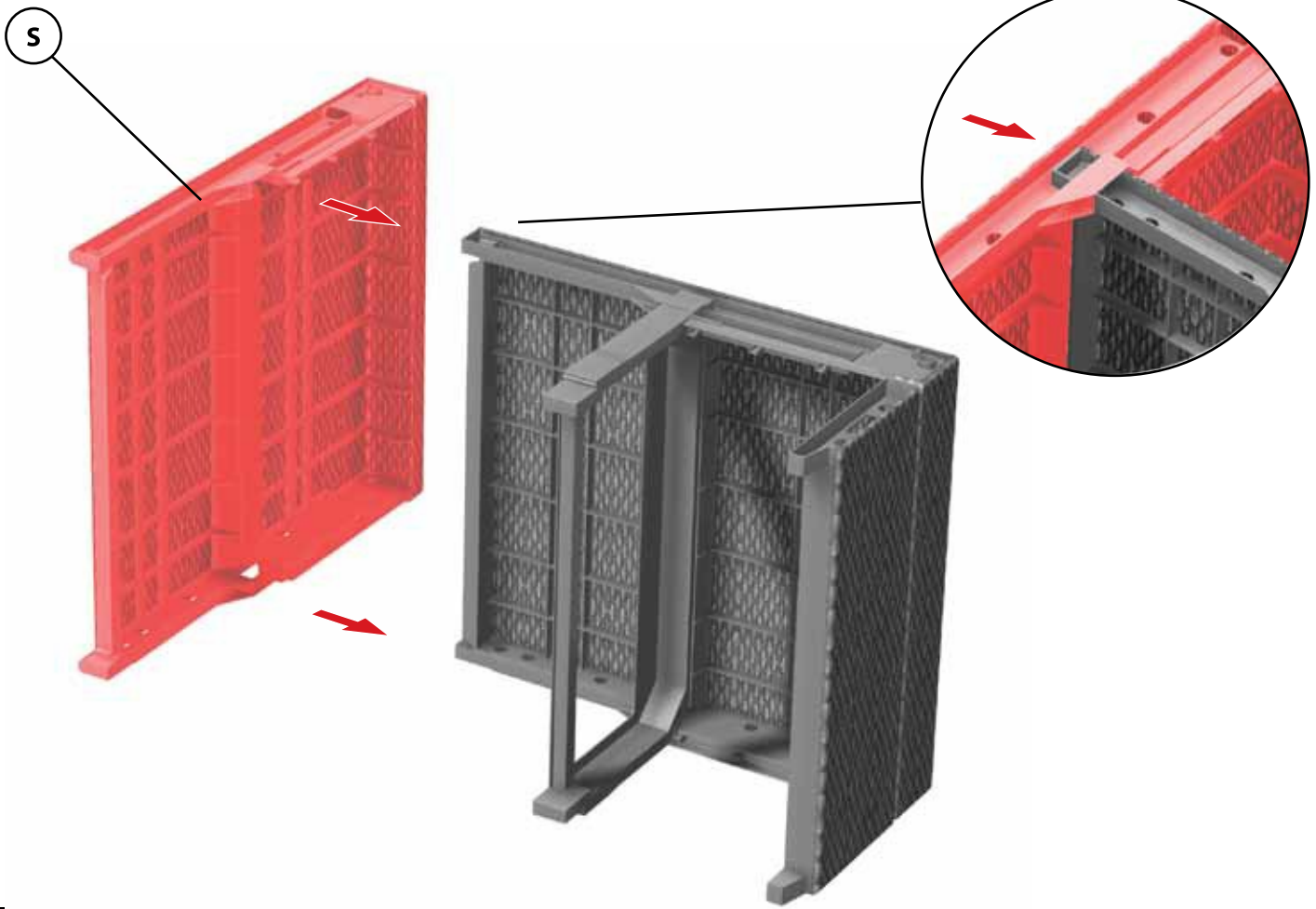

3

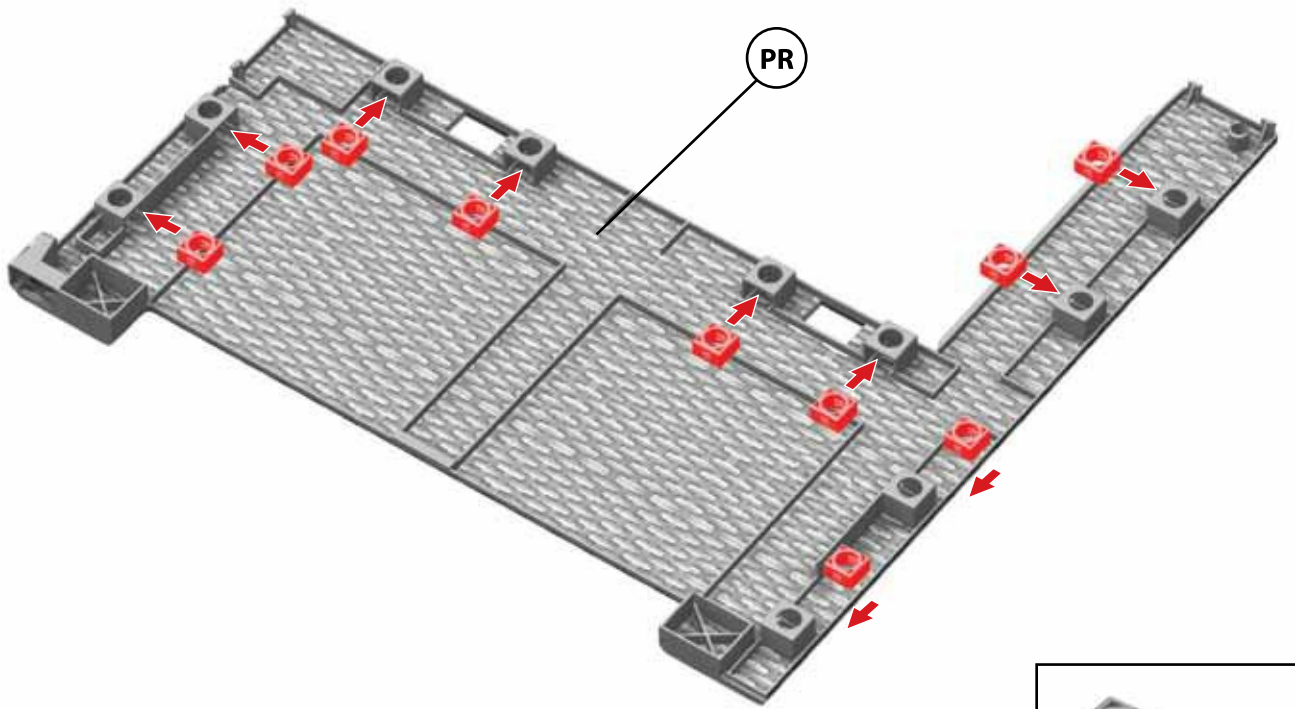

4

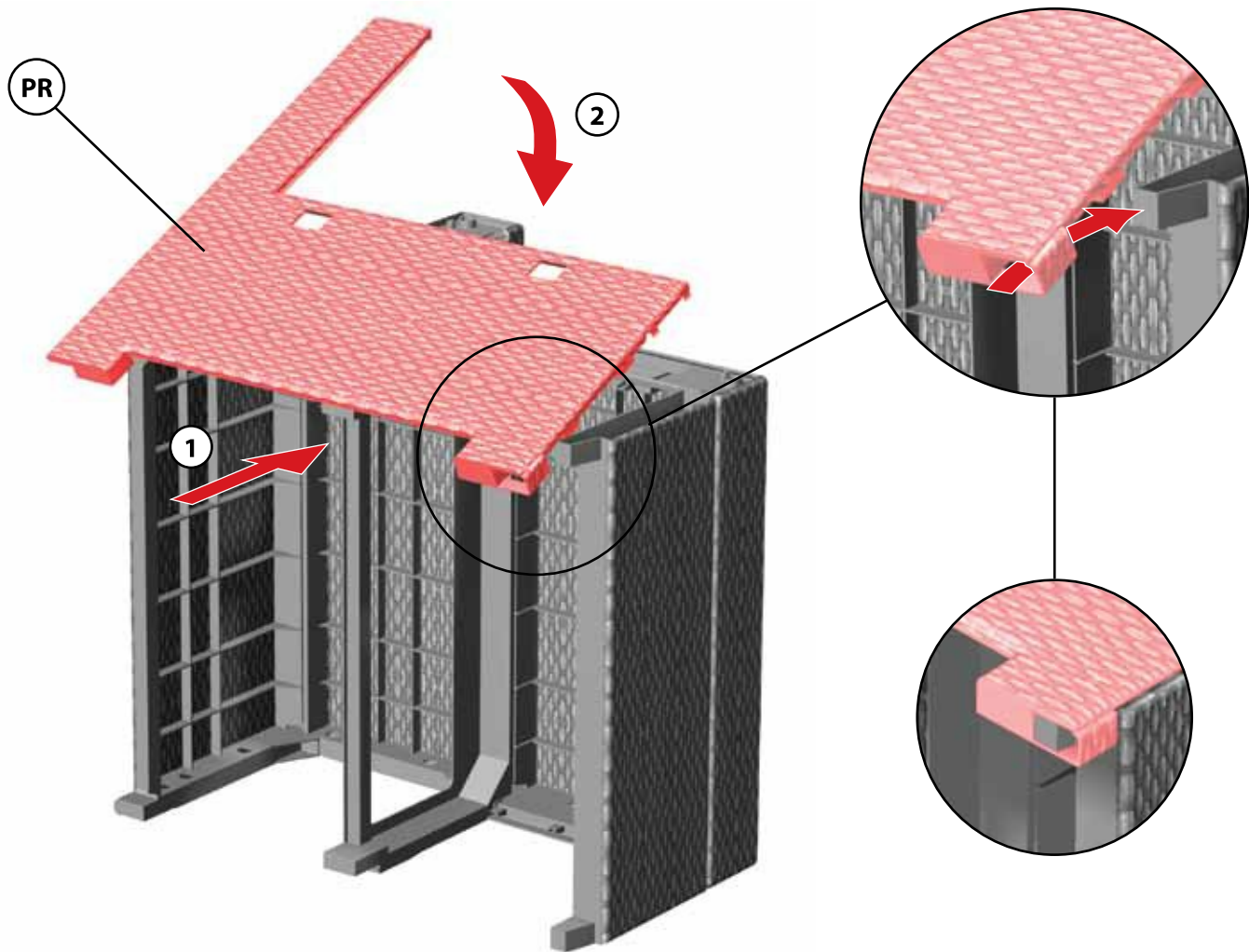

5

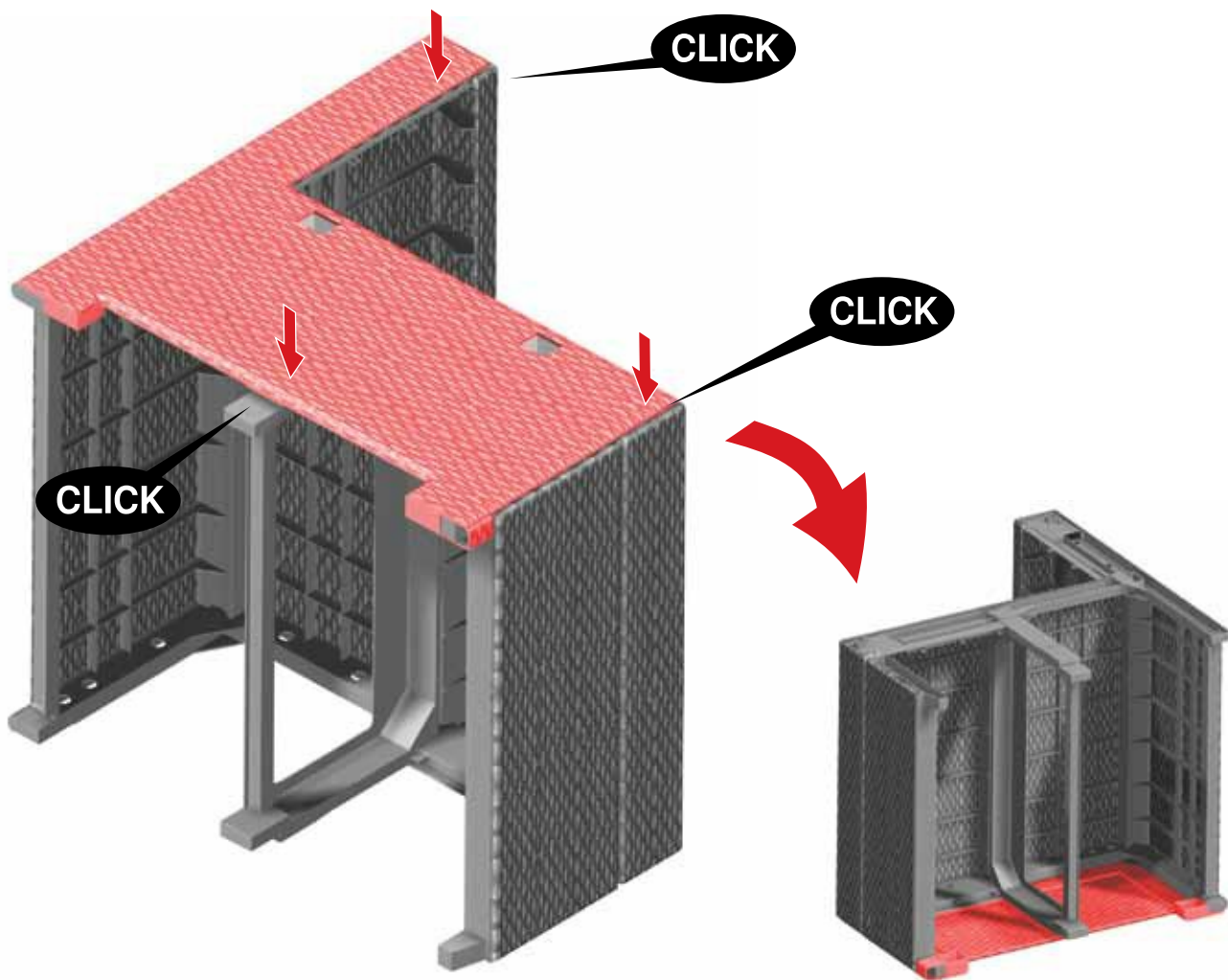

6

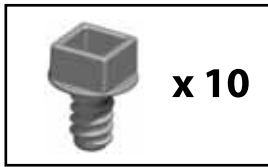
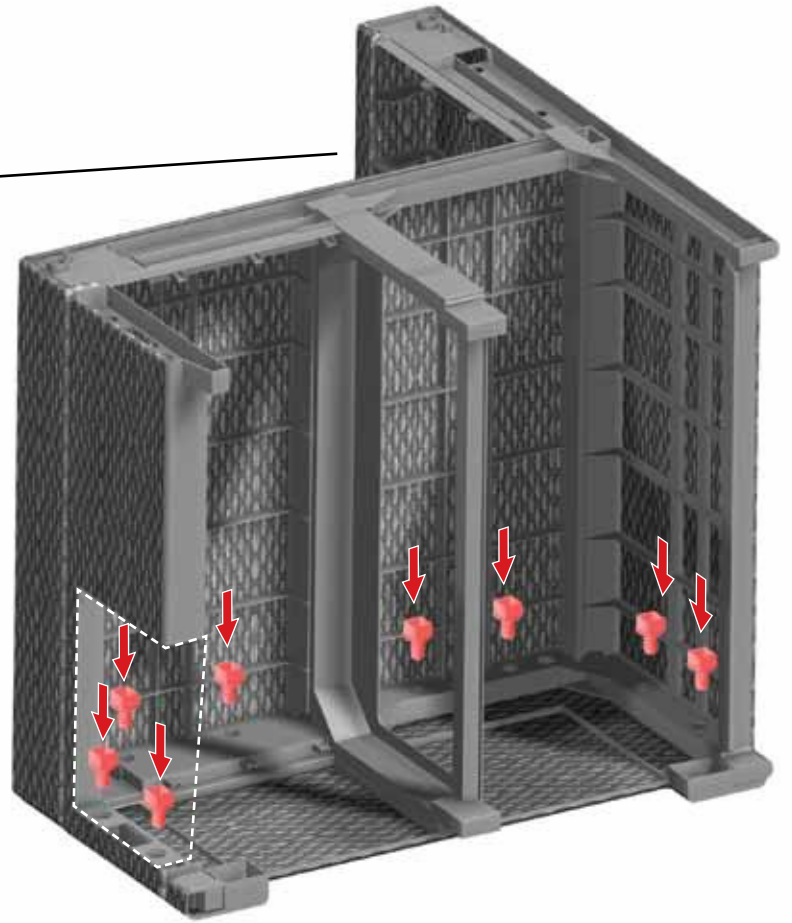
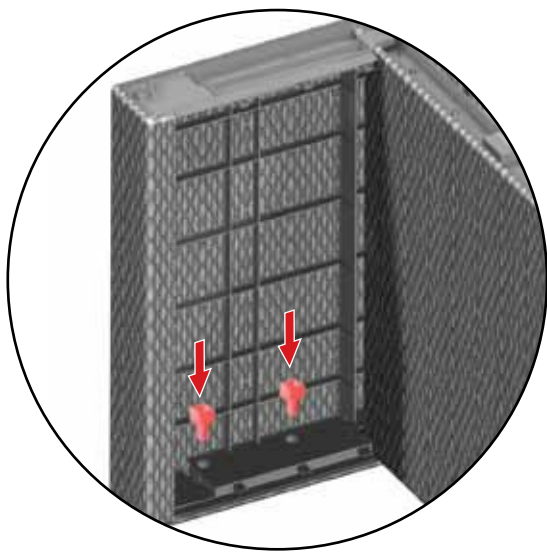

7

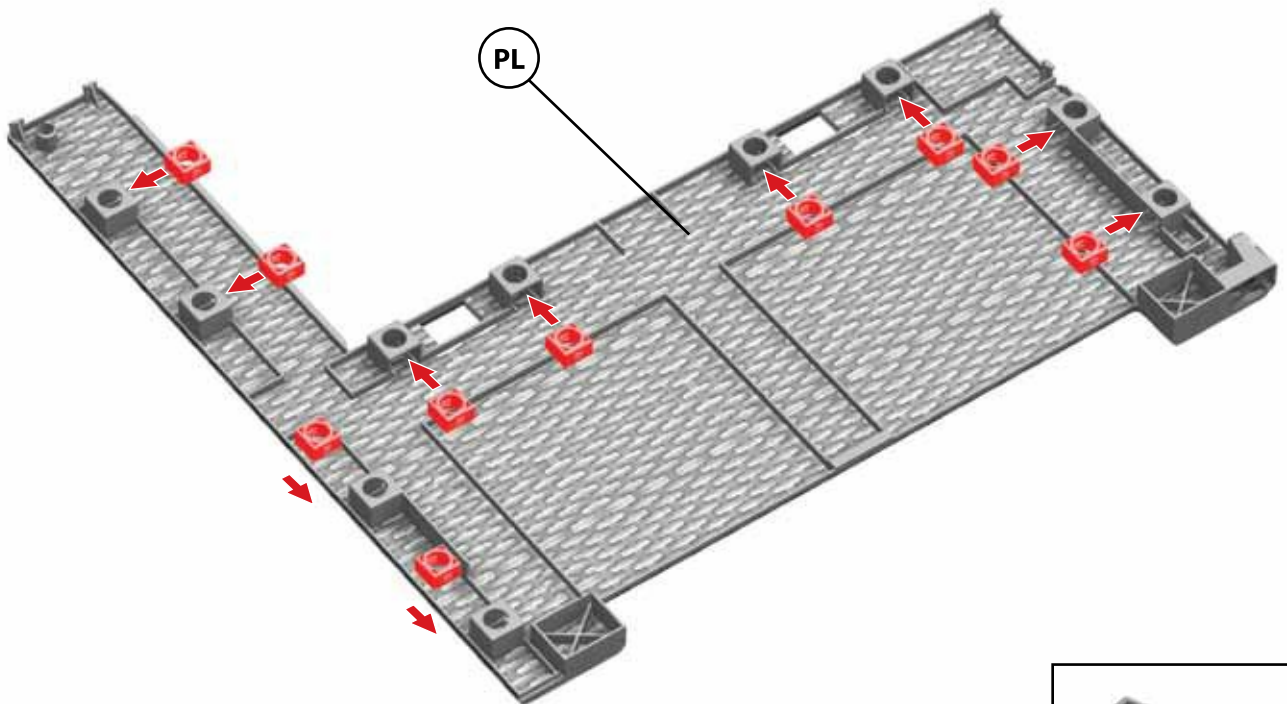

8

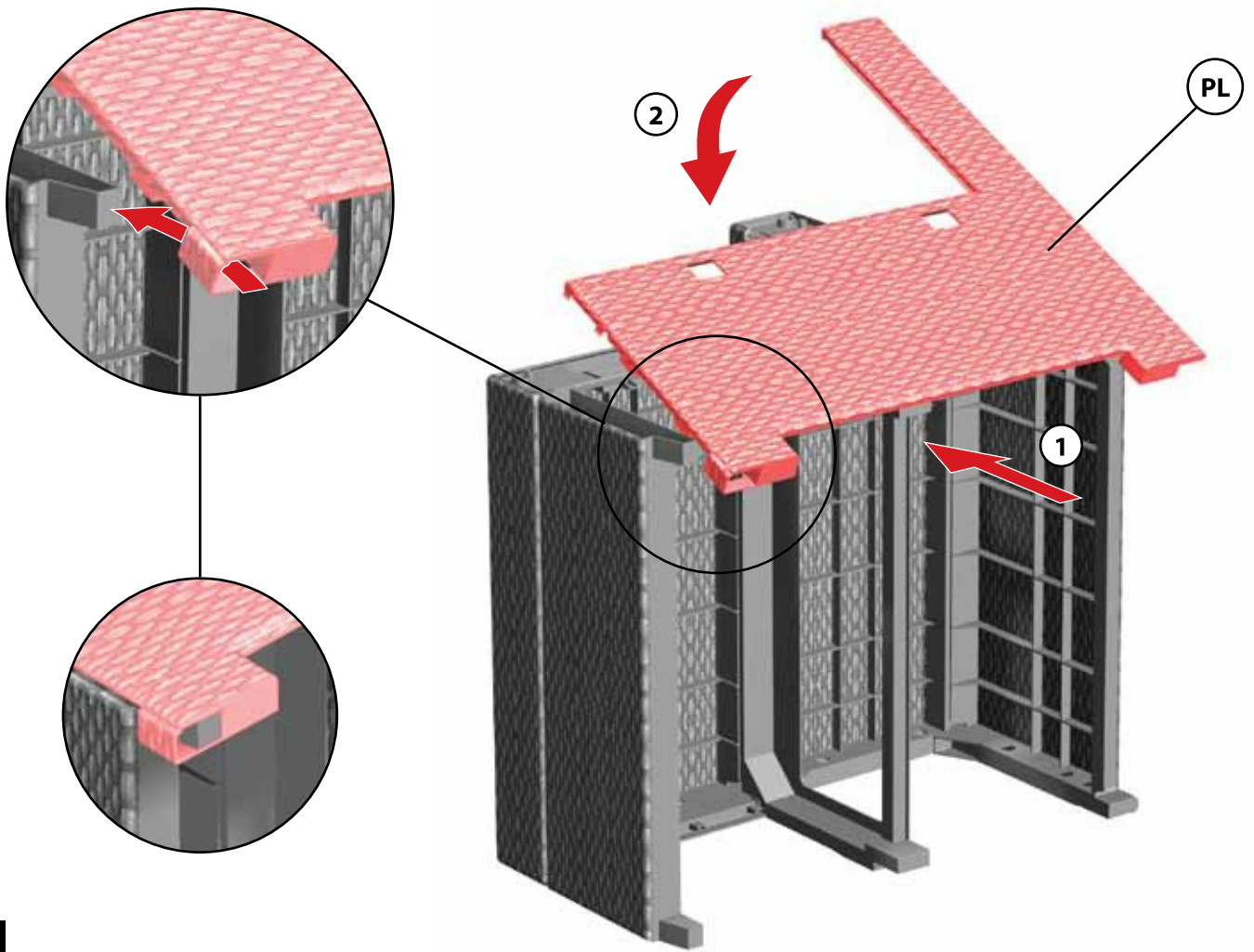

9

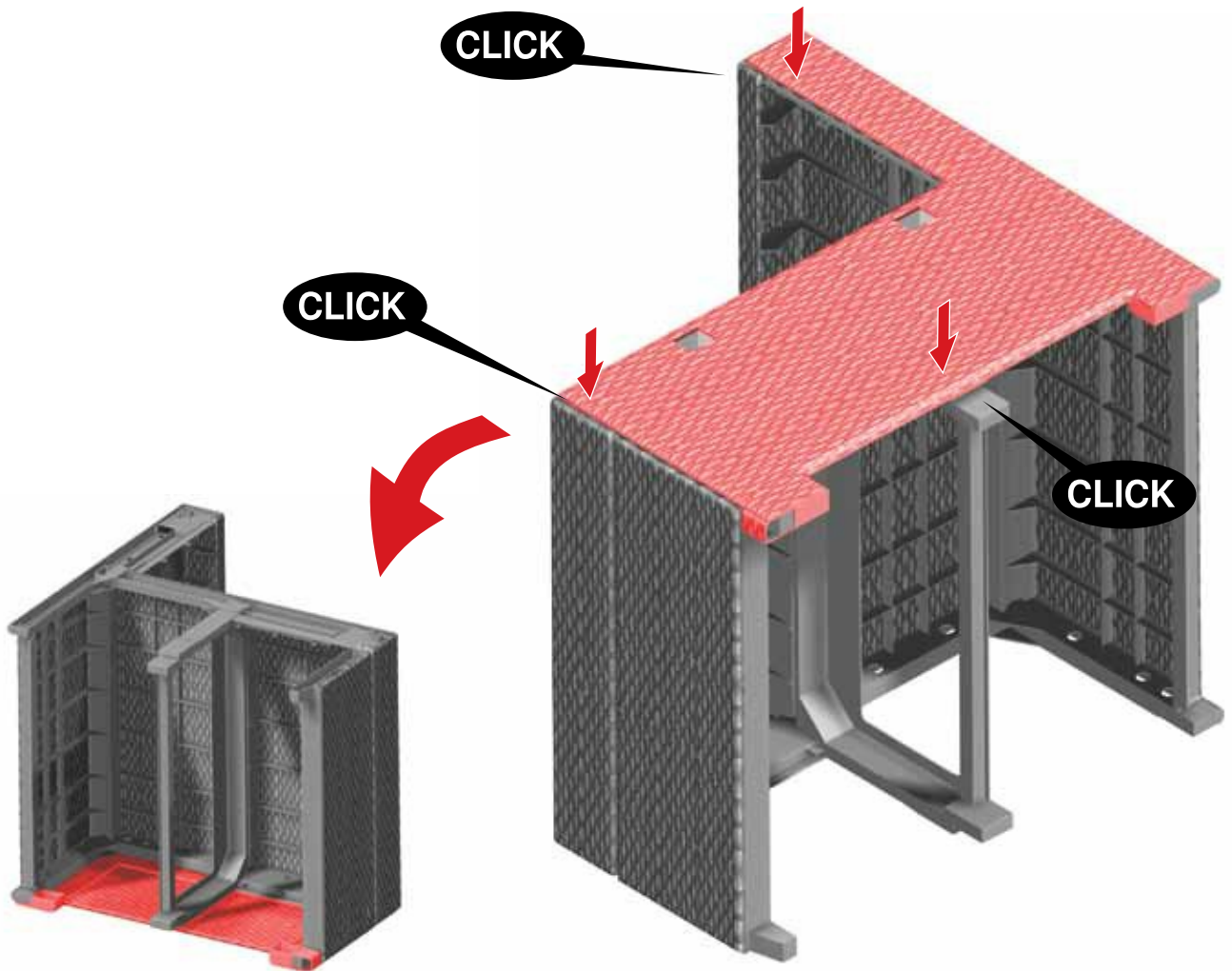

10

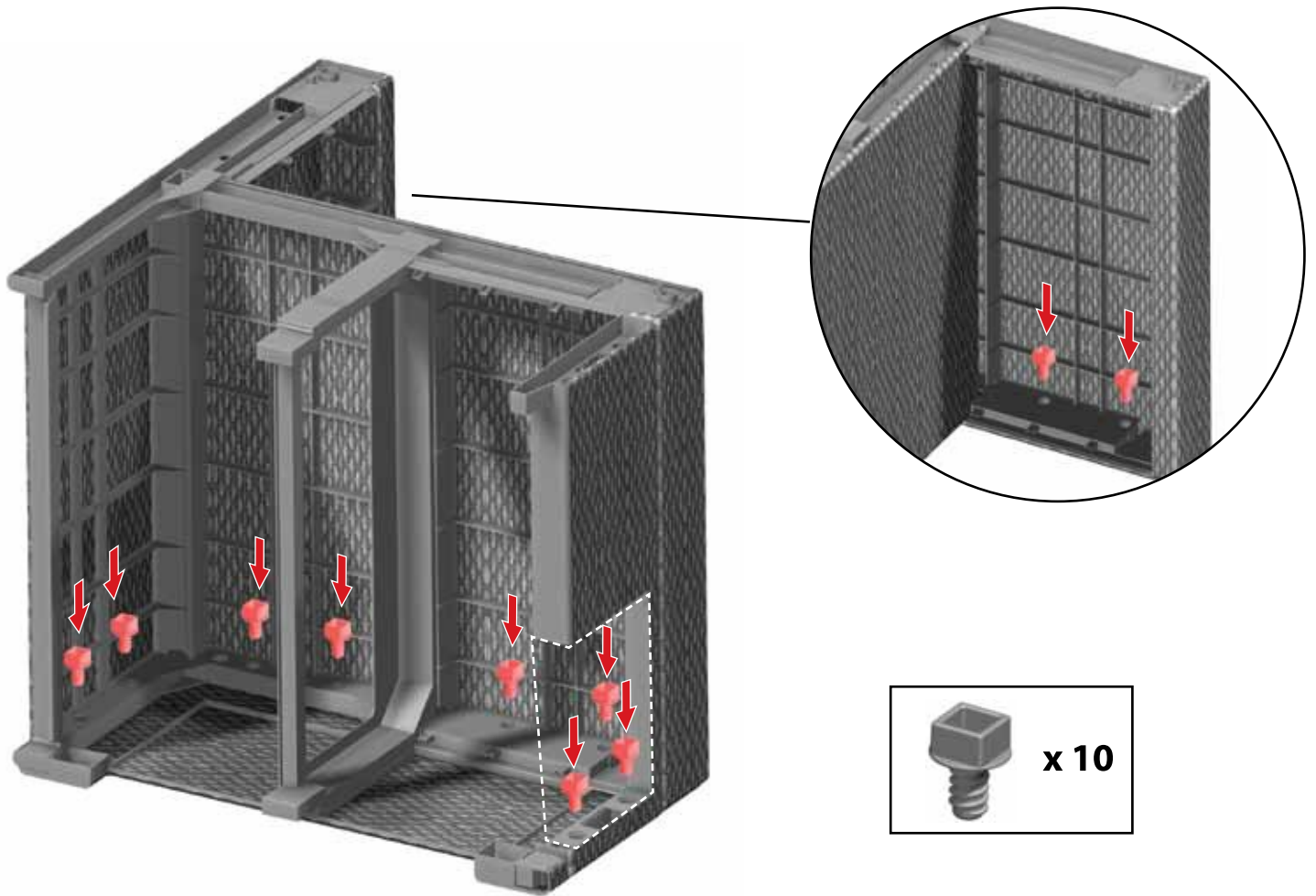

11

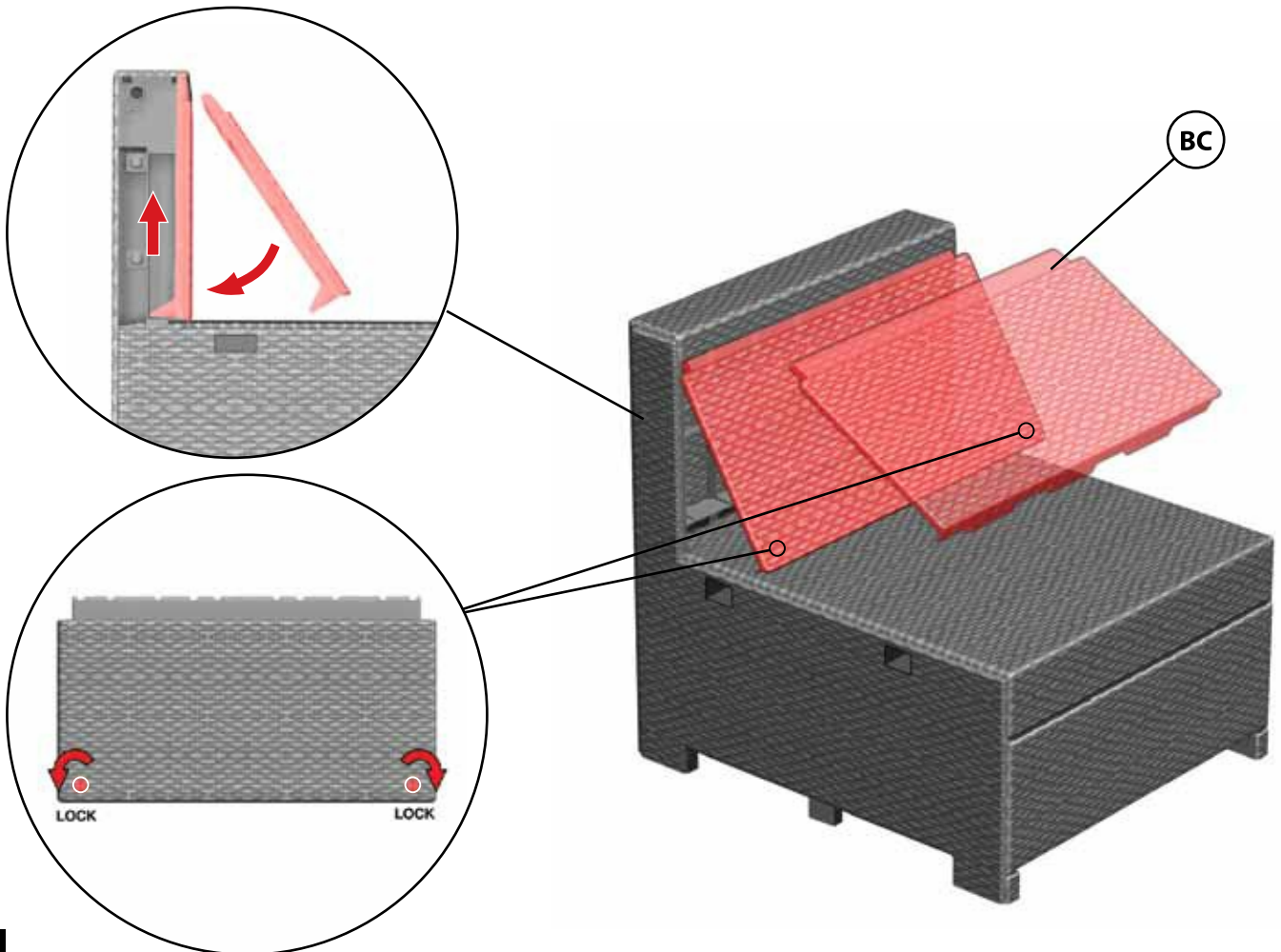

12

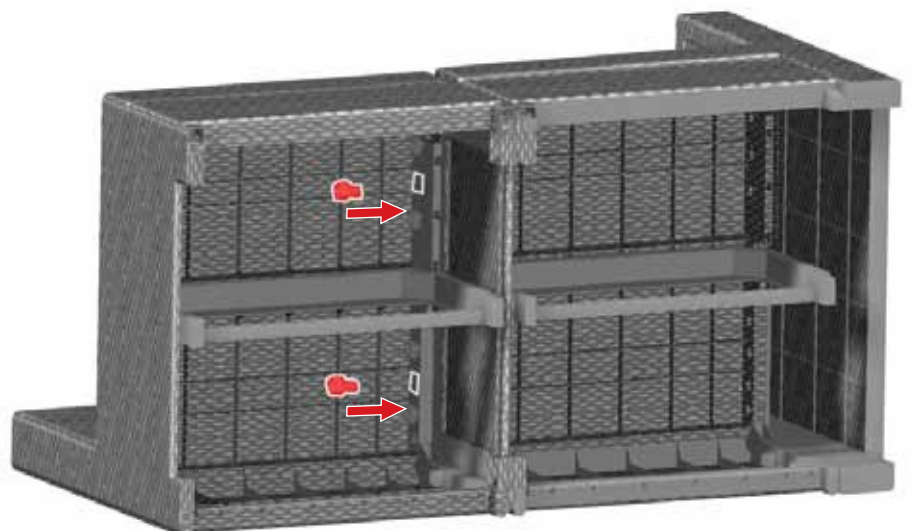
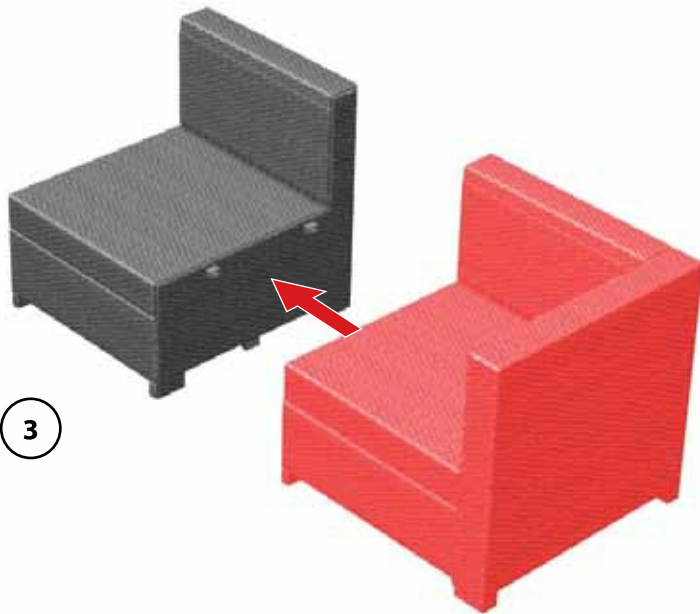
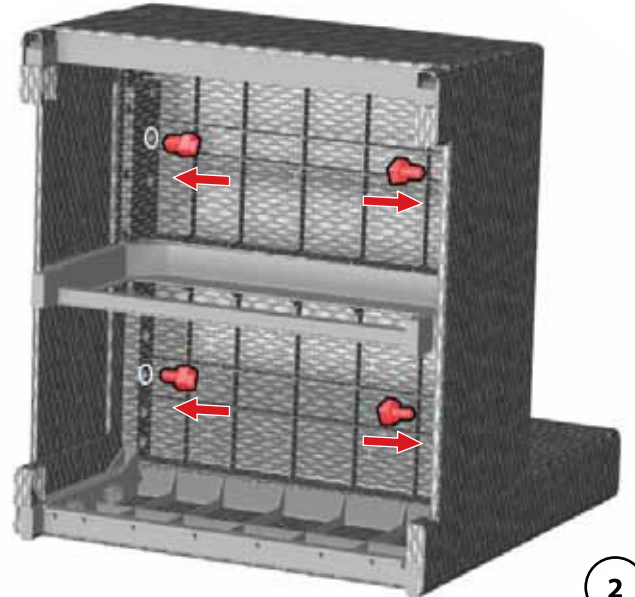
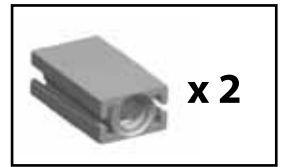
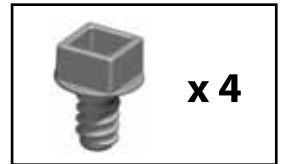
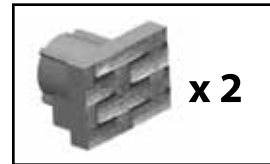
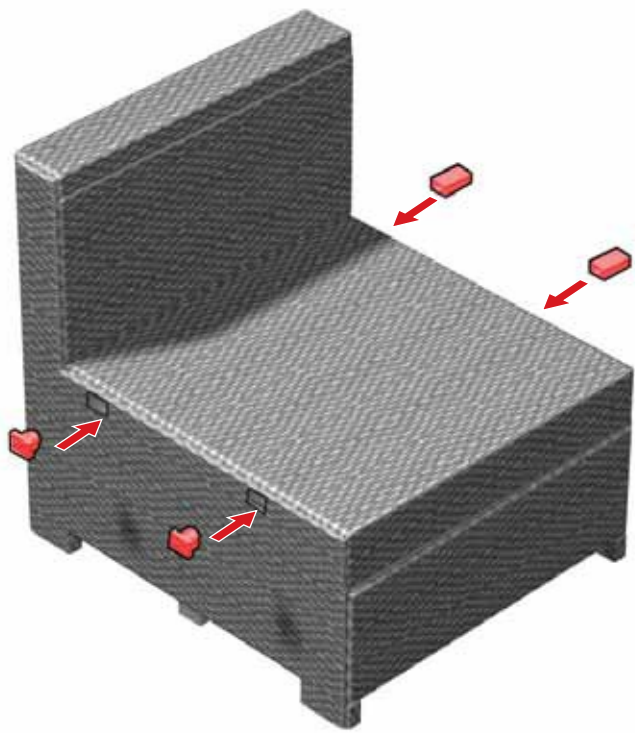

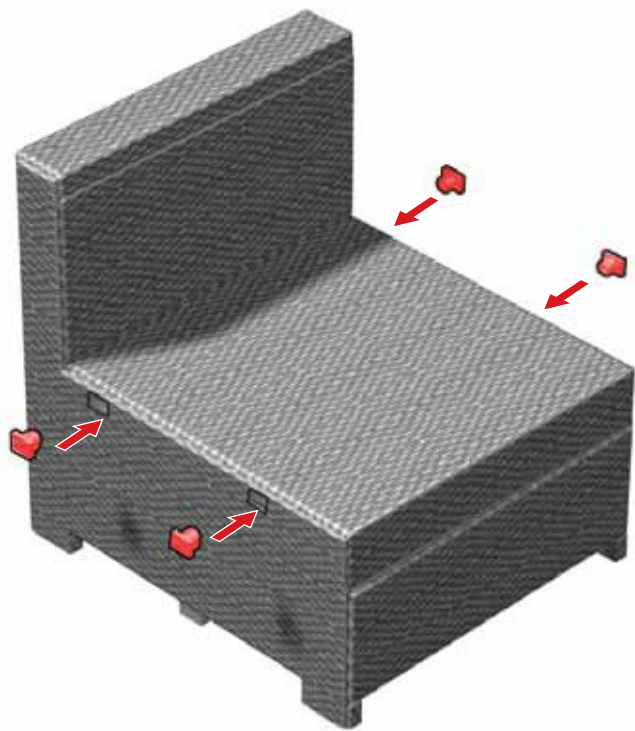

1

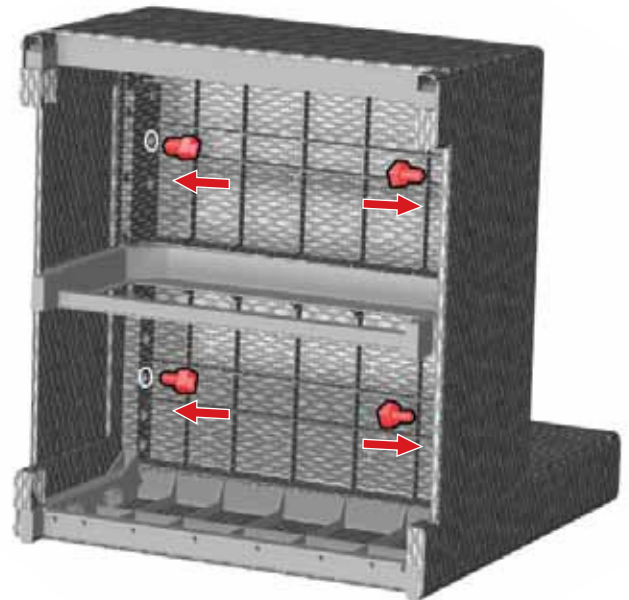
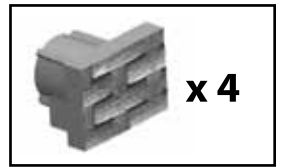
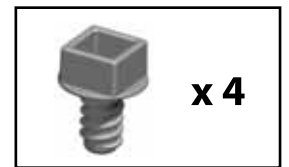

2

13B

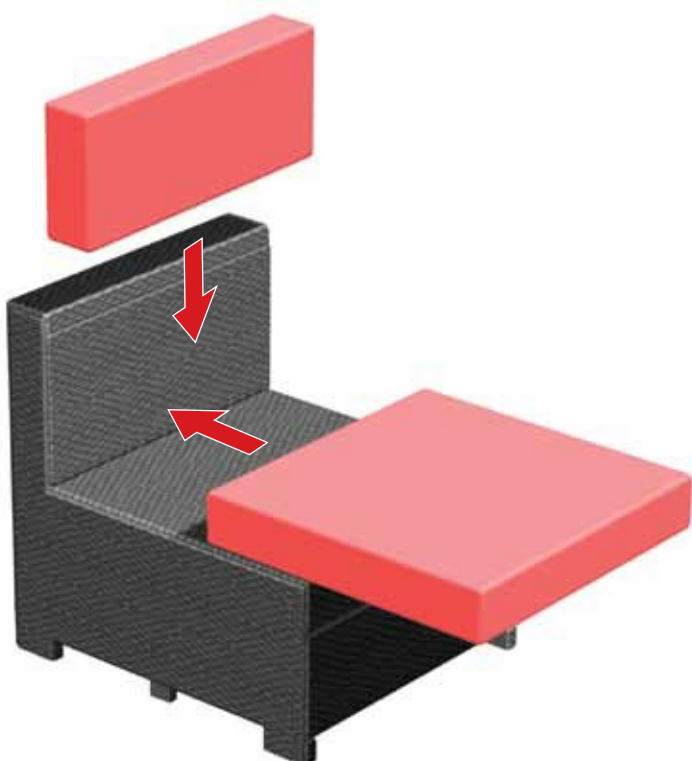

14



X2

<p>F x1</p>	<p>RS x1</p>	<p>SP x2</p>	<p>G x1</p>
<p>PL x1</p>	<p>BC x1</p>	<p>x4</p>	<p>x1</p>
<p>S x2</p>	<p>L x1</p>	<p>x1</p>	<p>x20</p>
<p>x1</p>	<p>x1</p>	<p>x18</p>	<p>x1</p>
		<p>x1</p>	<p>x2</p>

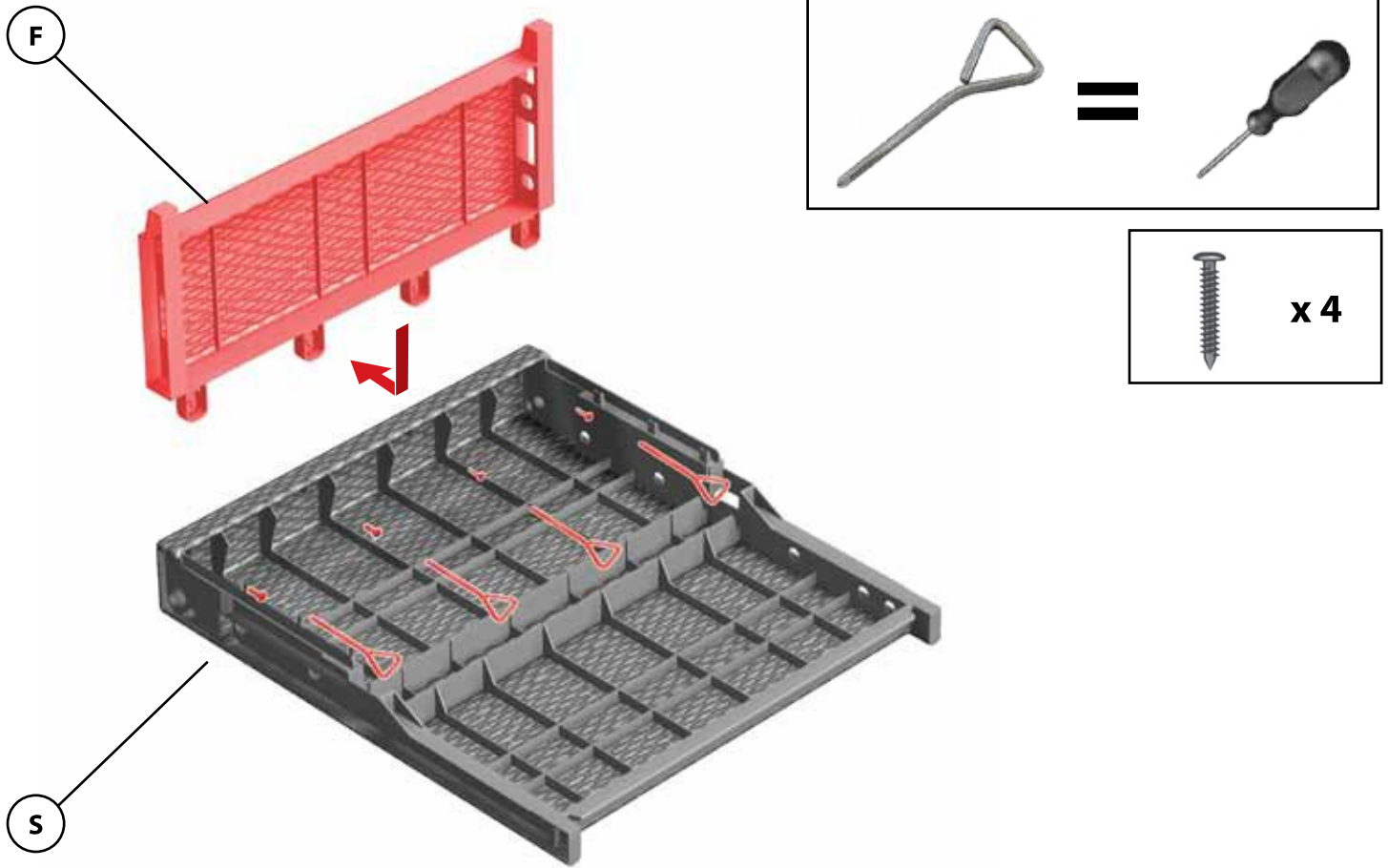

1

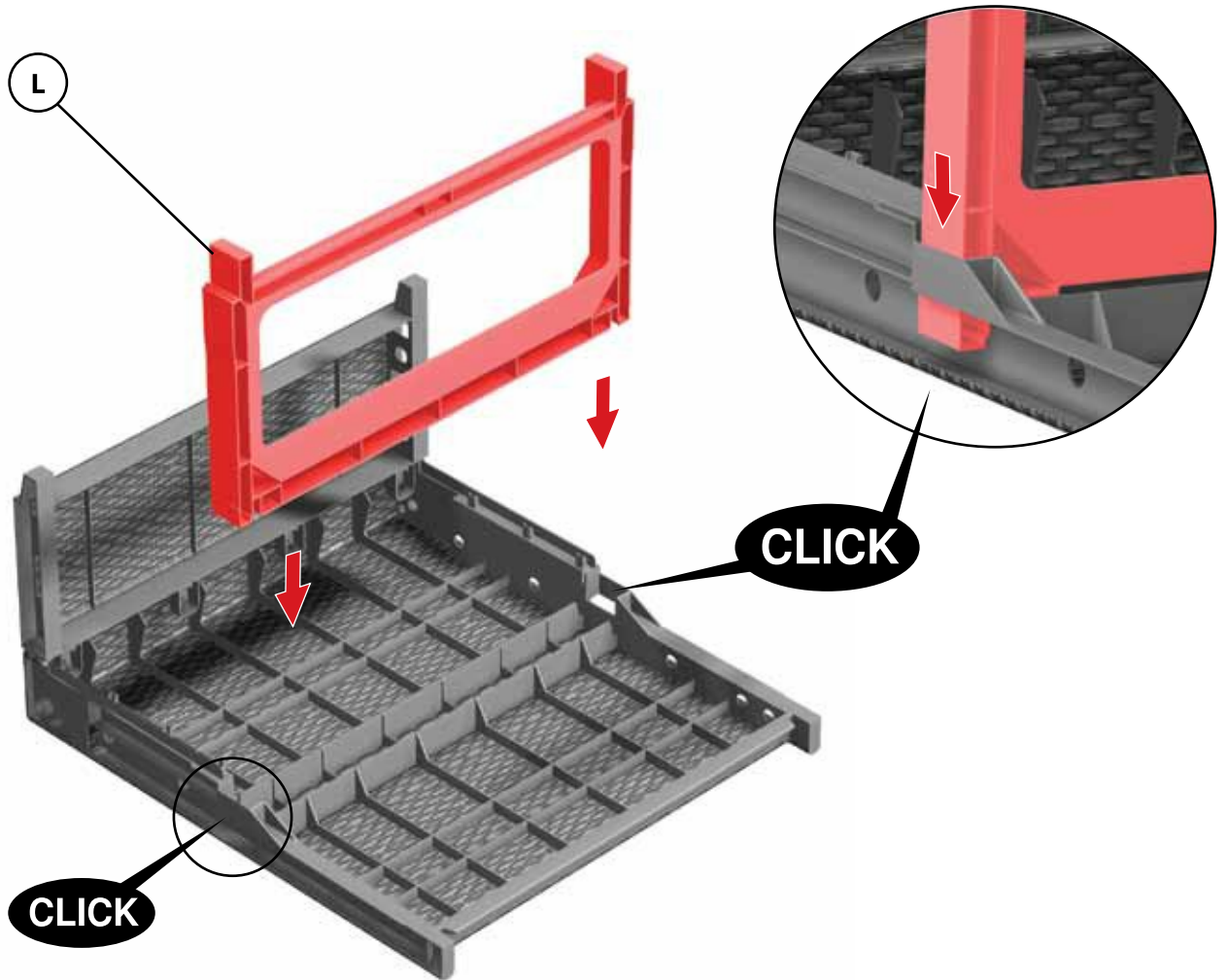

2

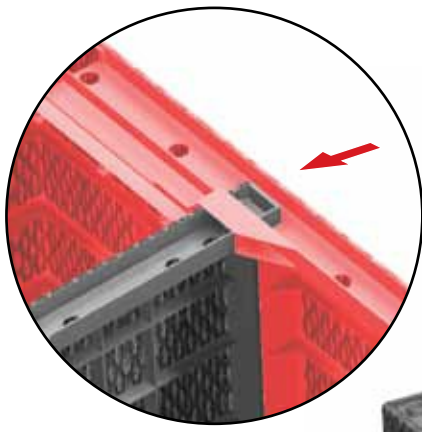

3

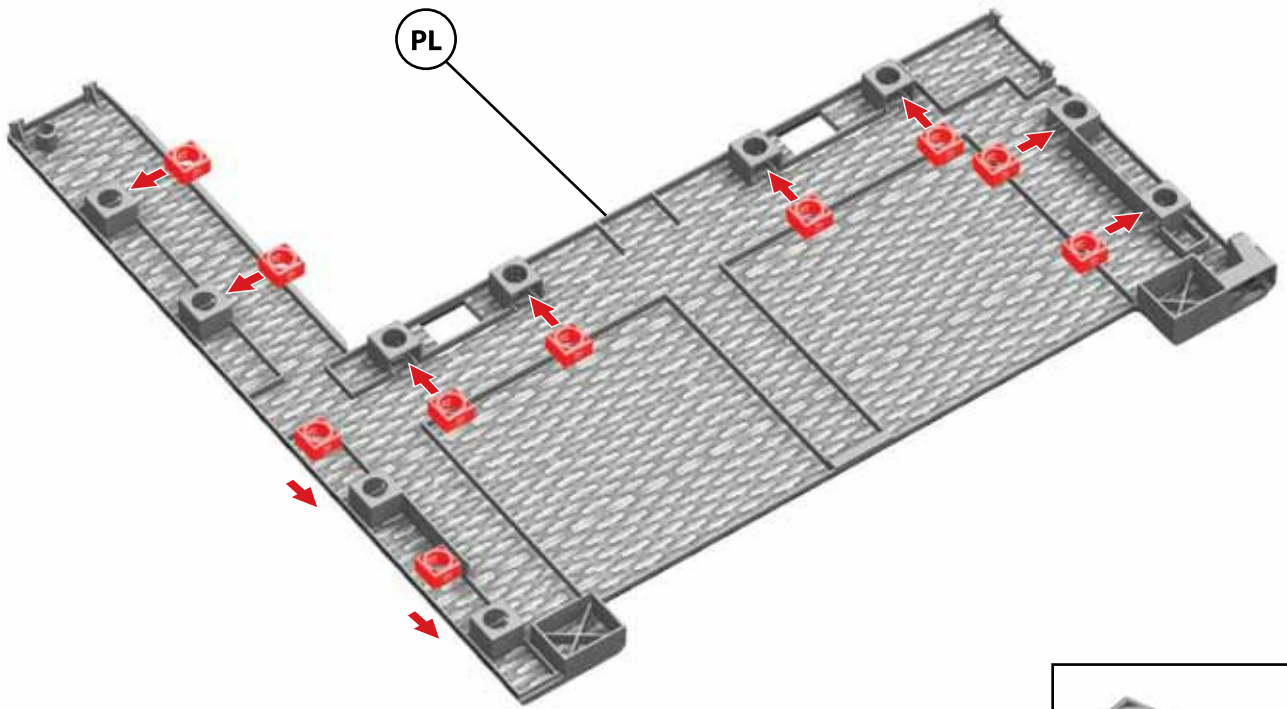

4

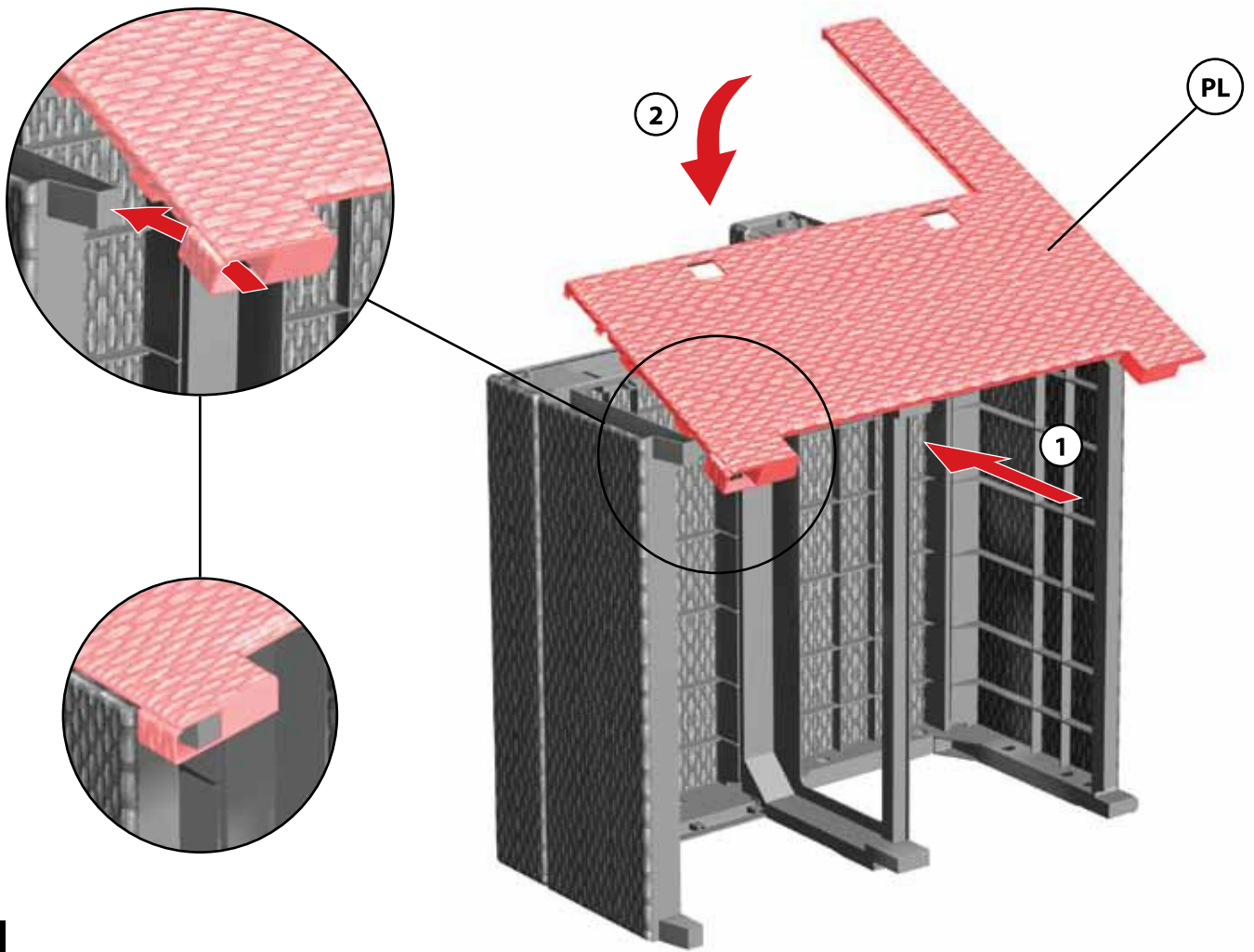

5

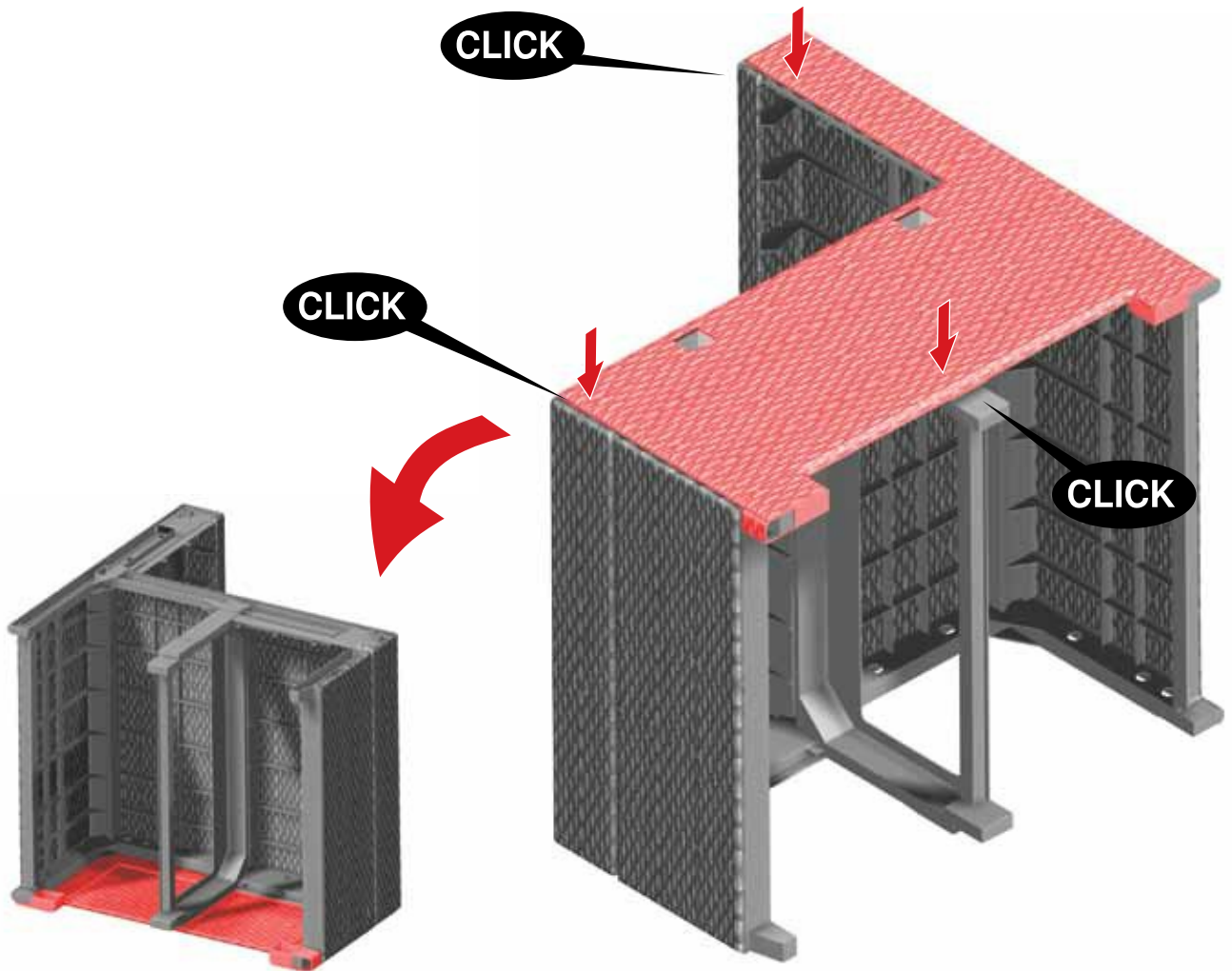

6

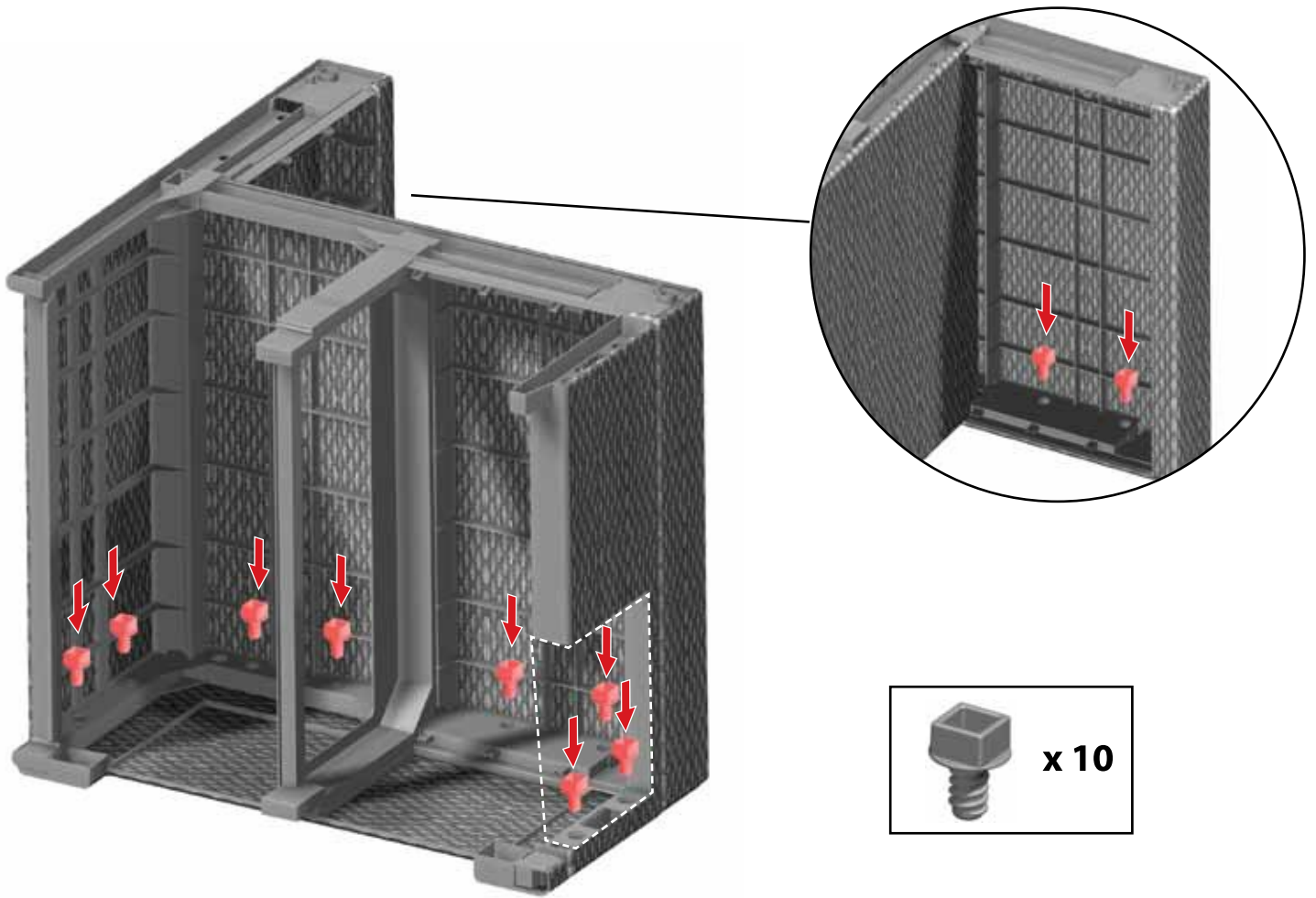

7

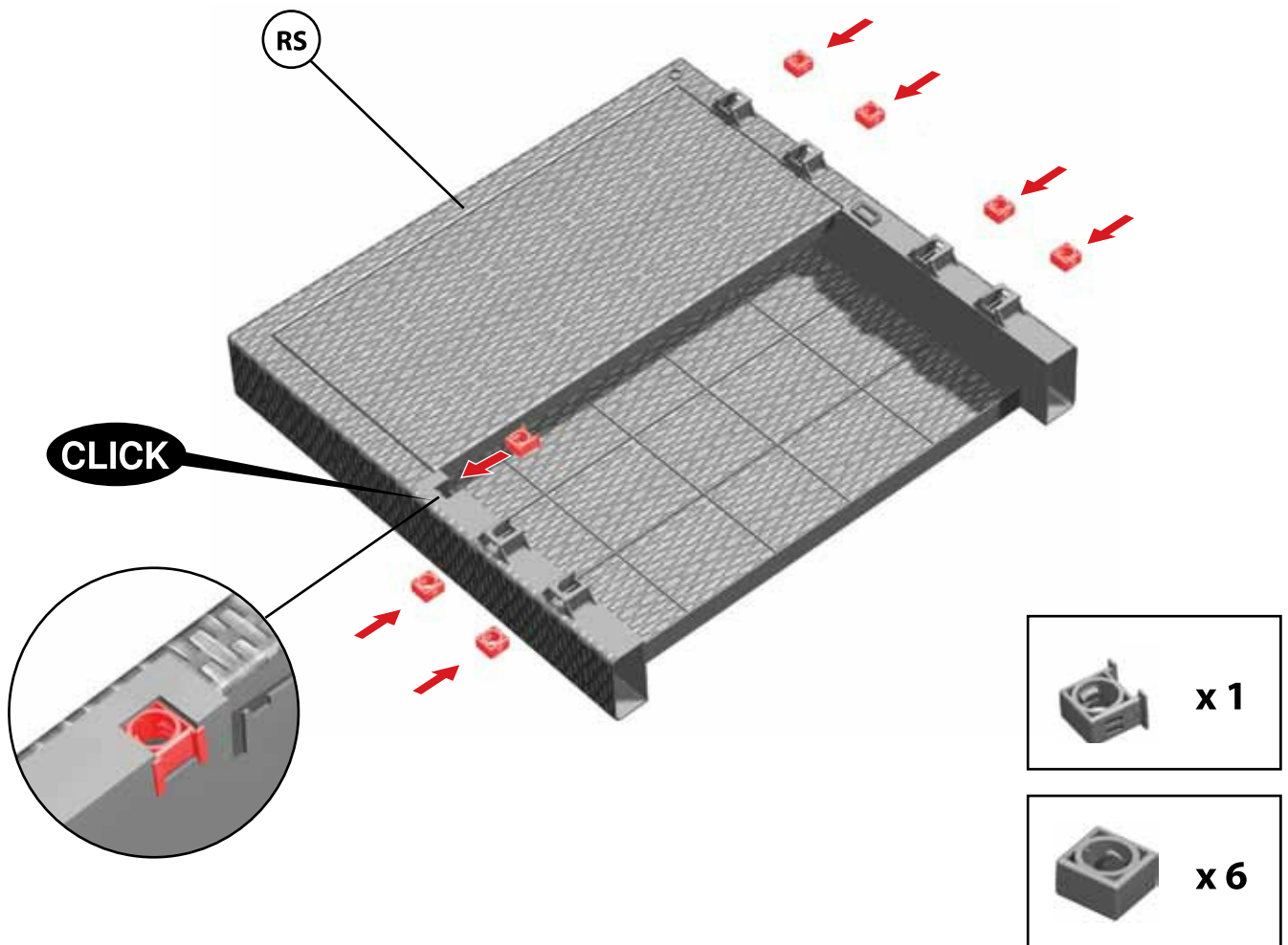

8

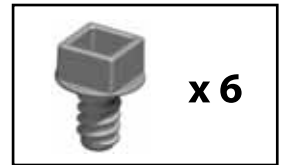
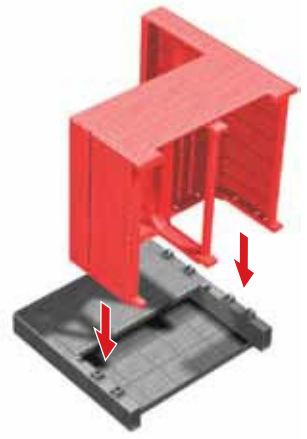
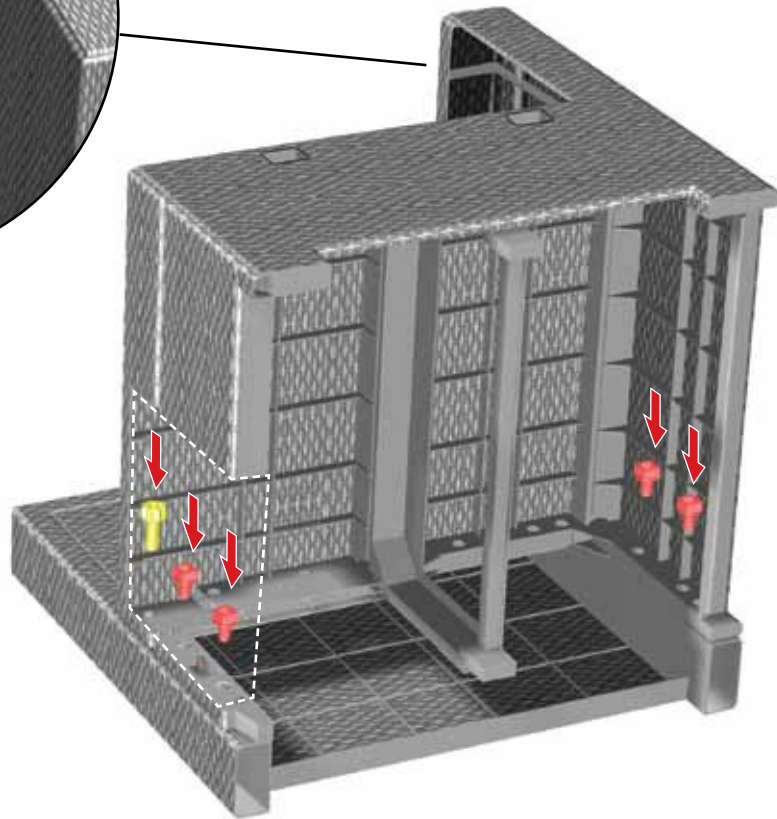
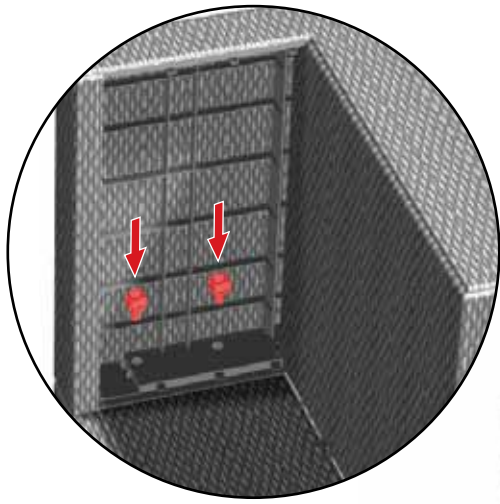

9

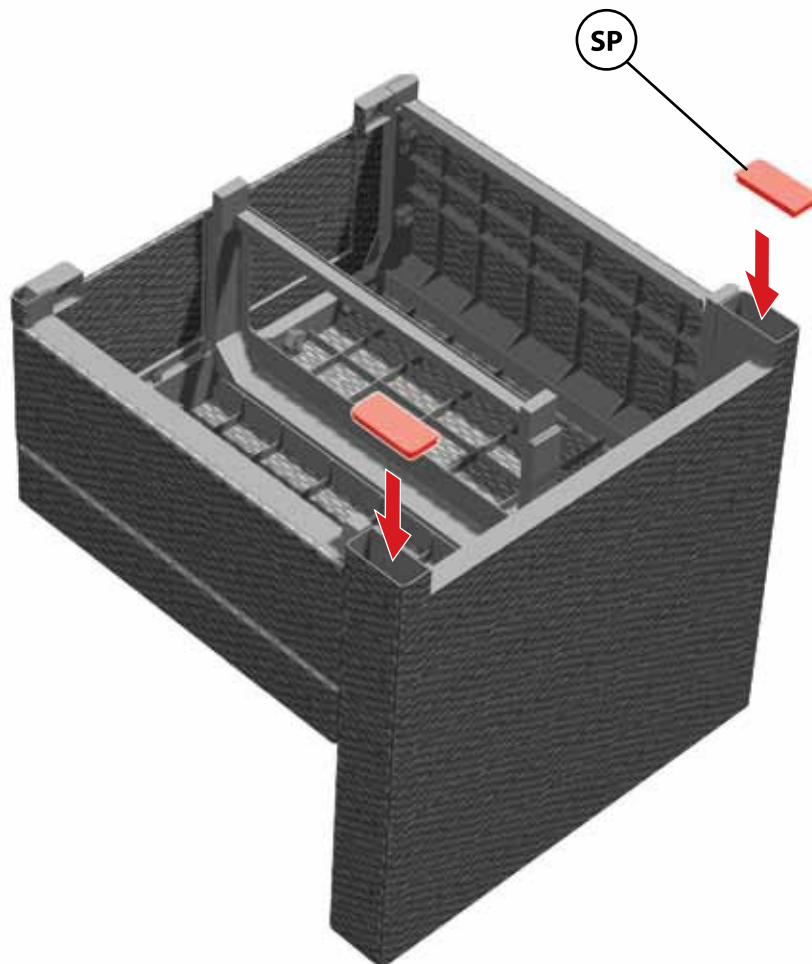

10

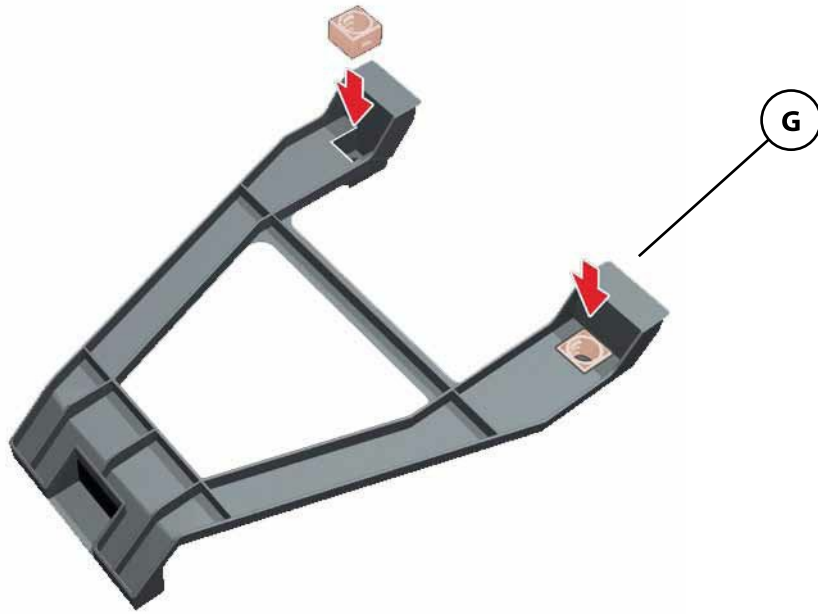
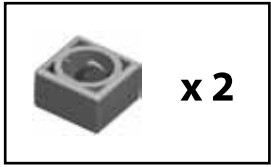

11

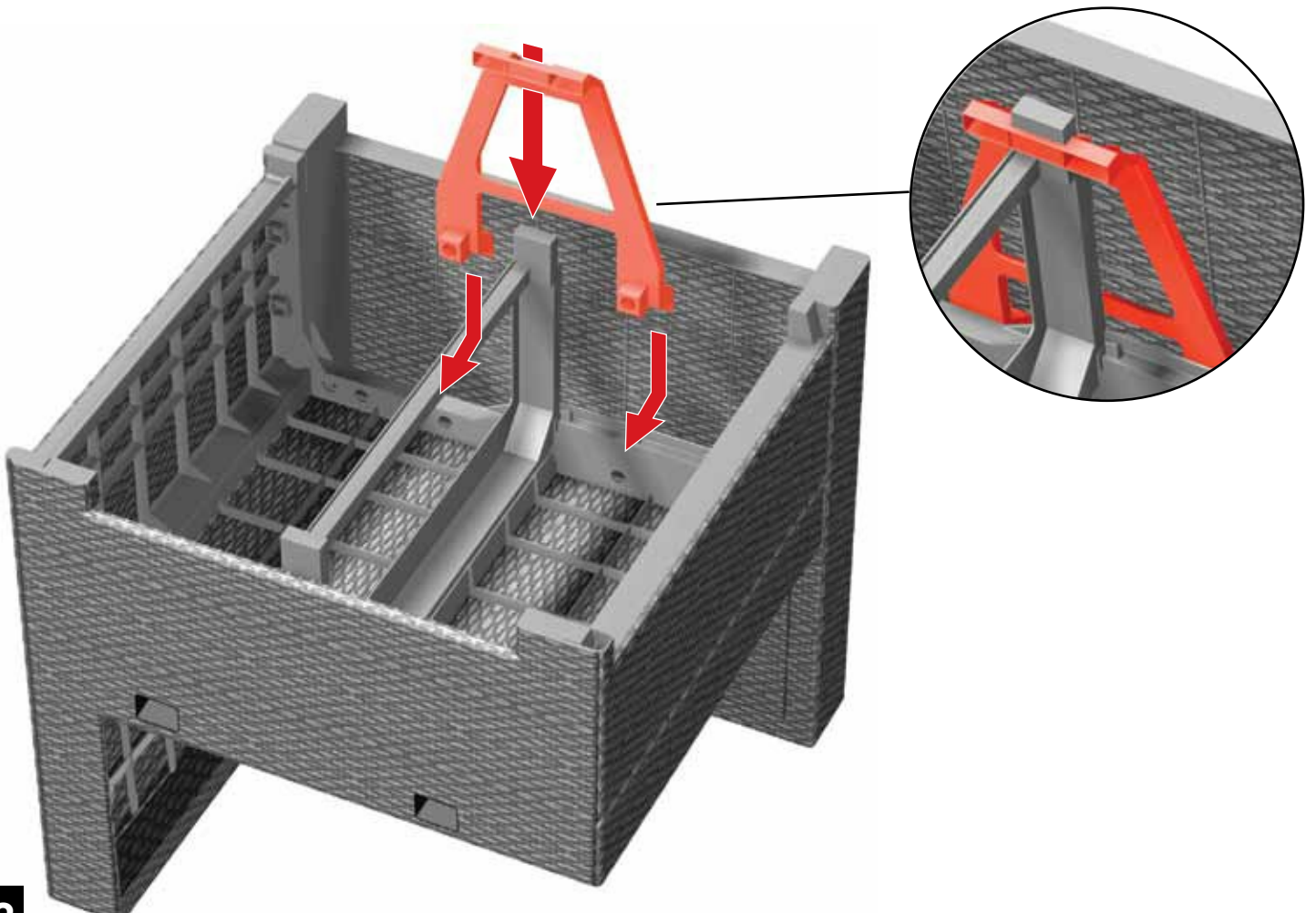

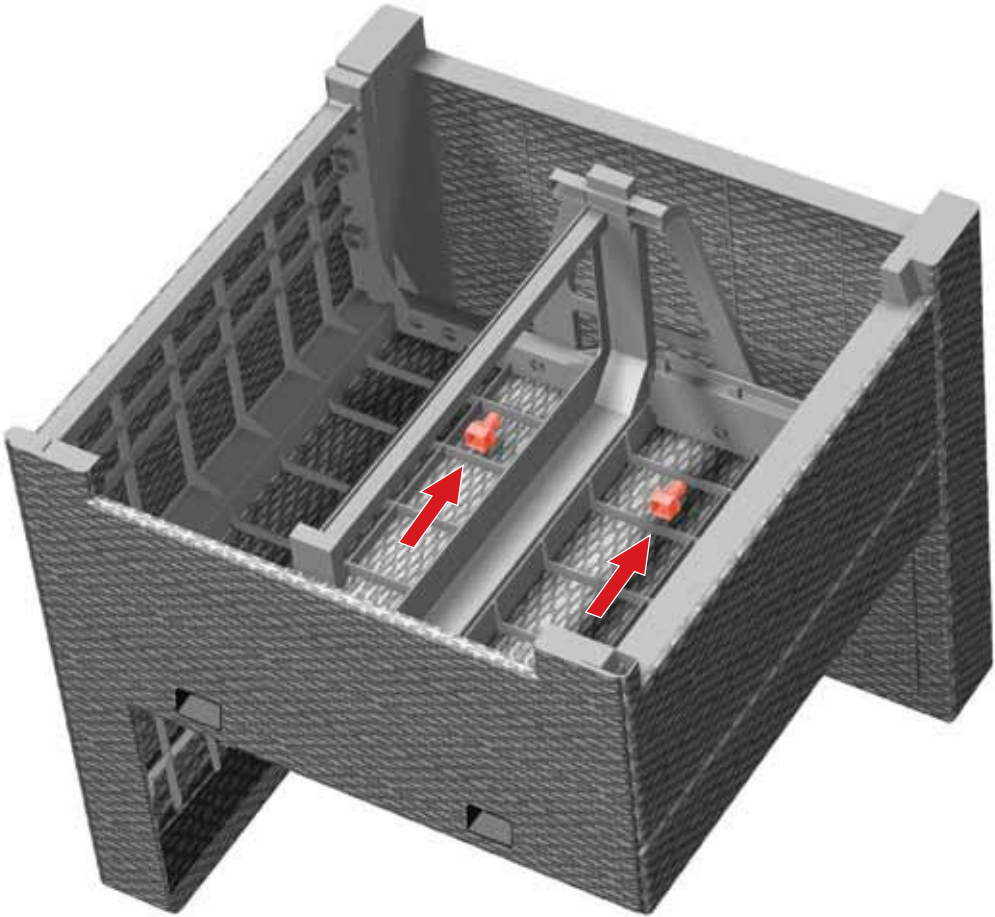
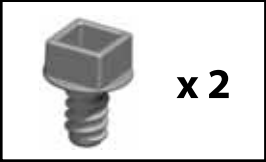

13

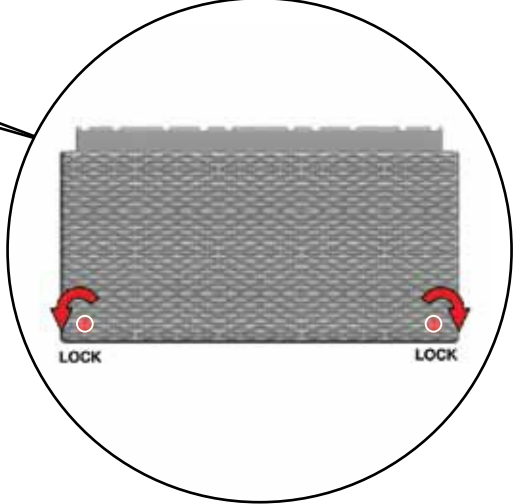
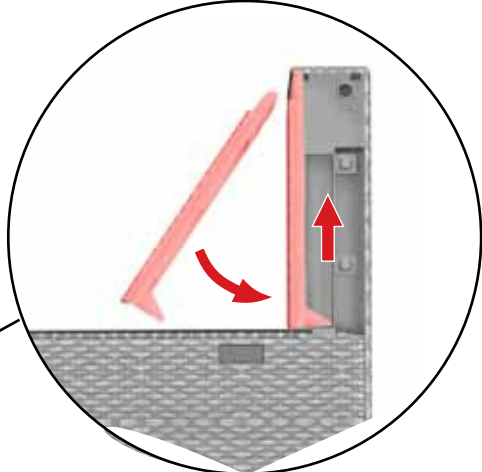
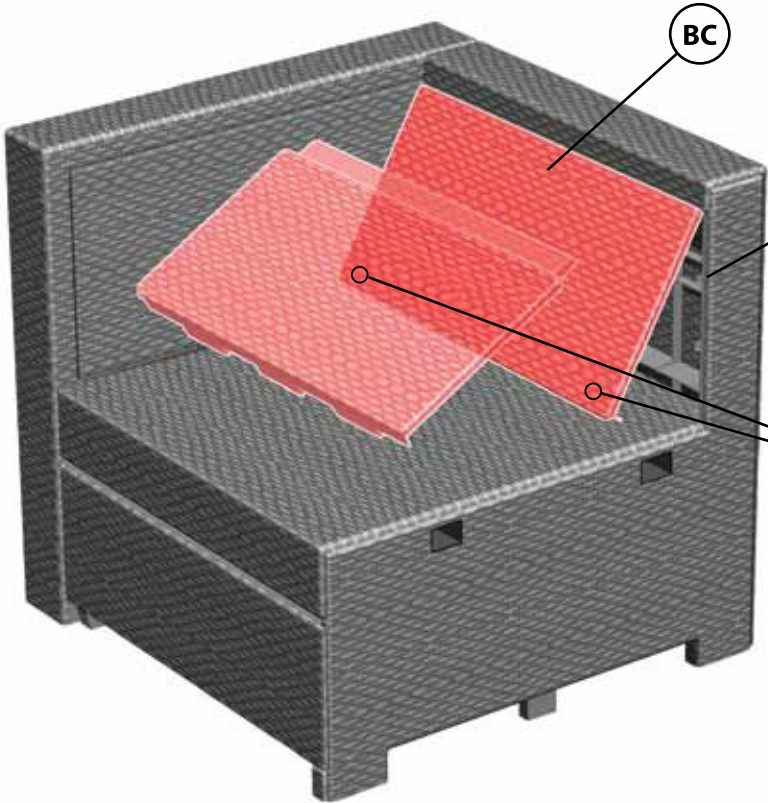

14

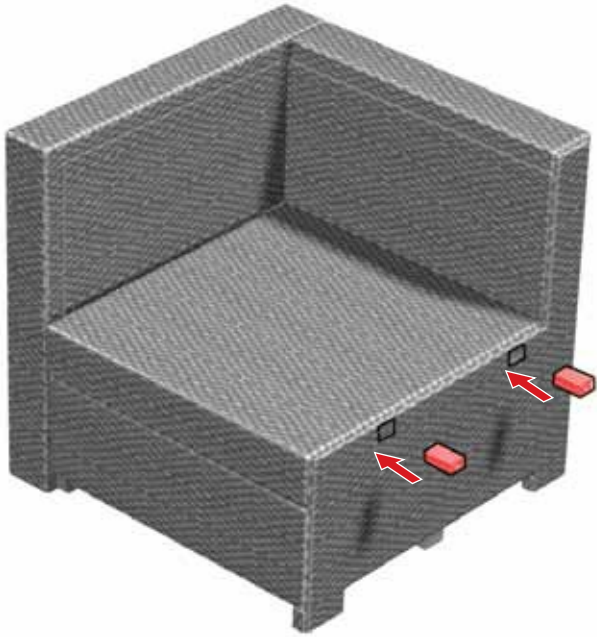

1

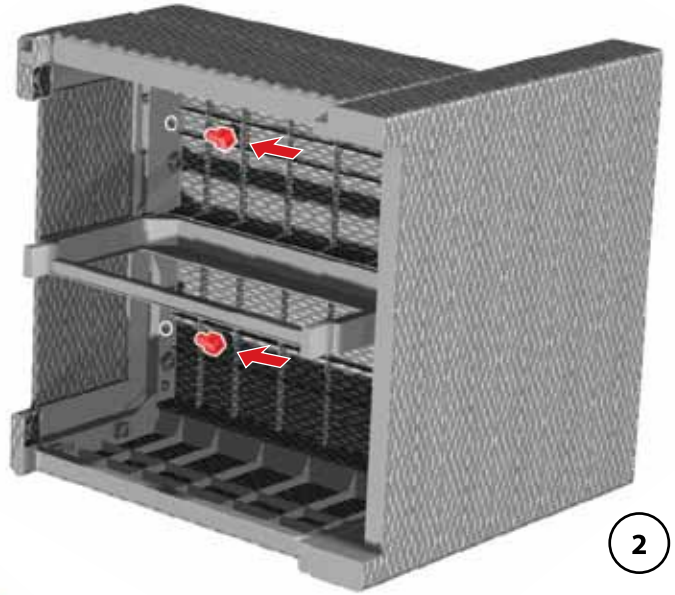
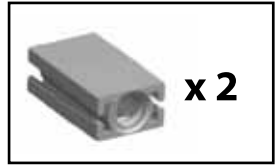
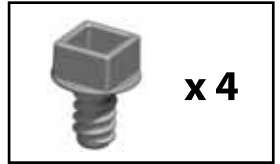

2

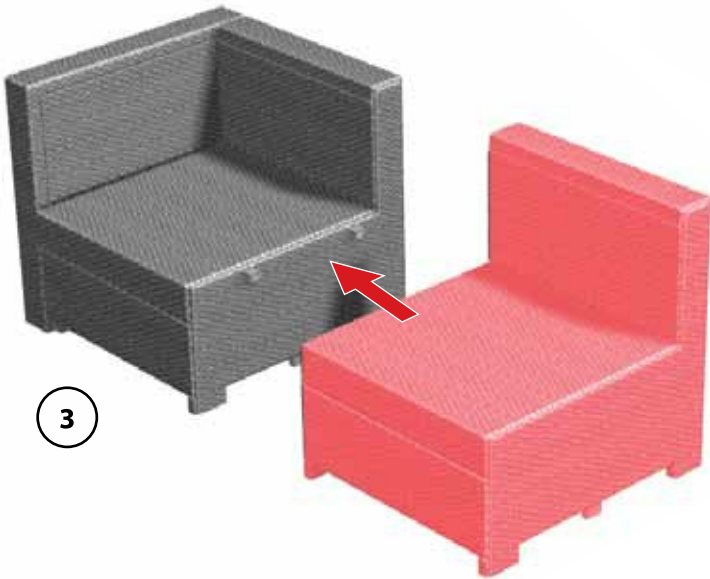

3

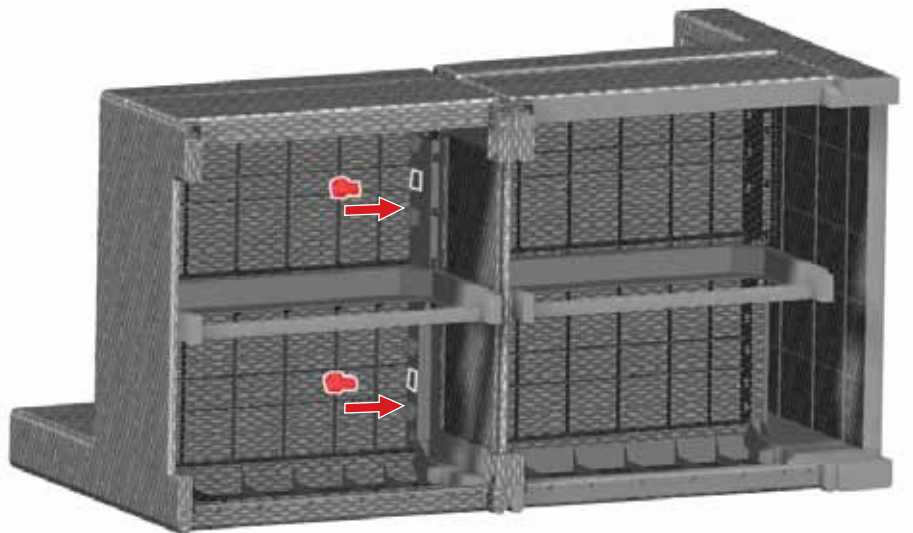

4

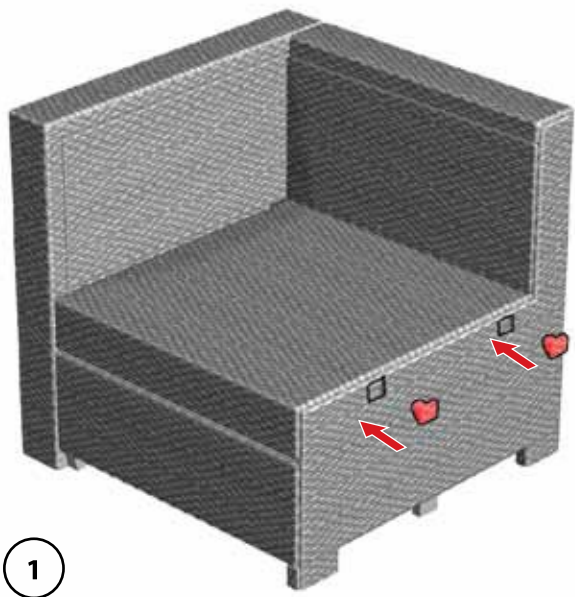

1

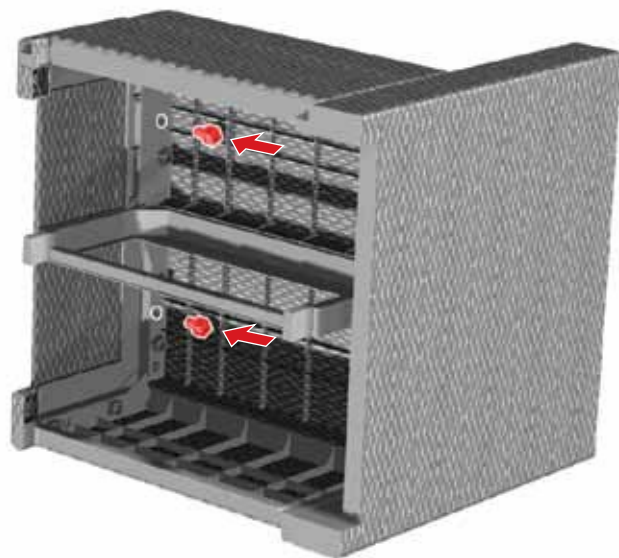

2

15B

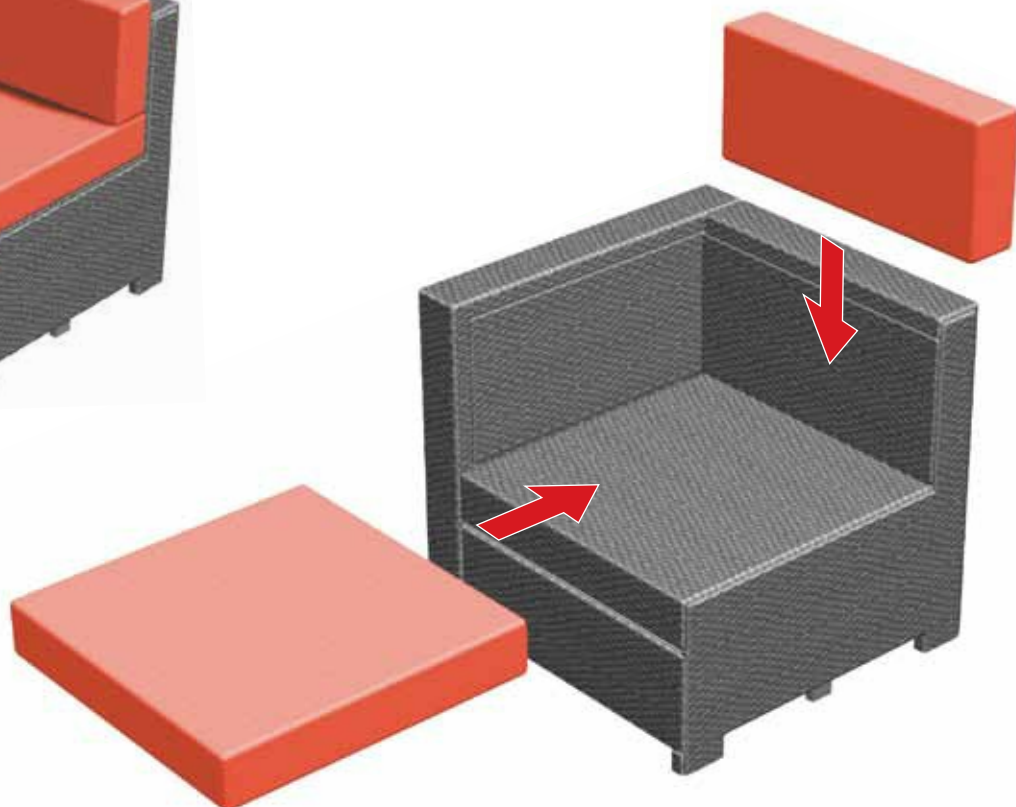

16

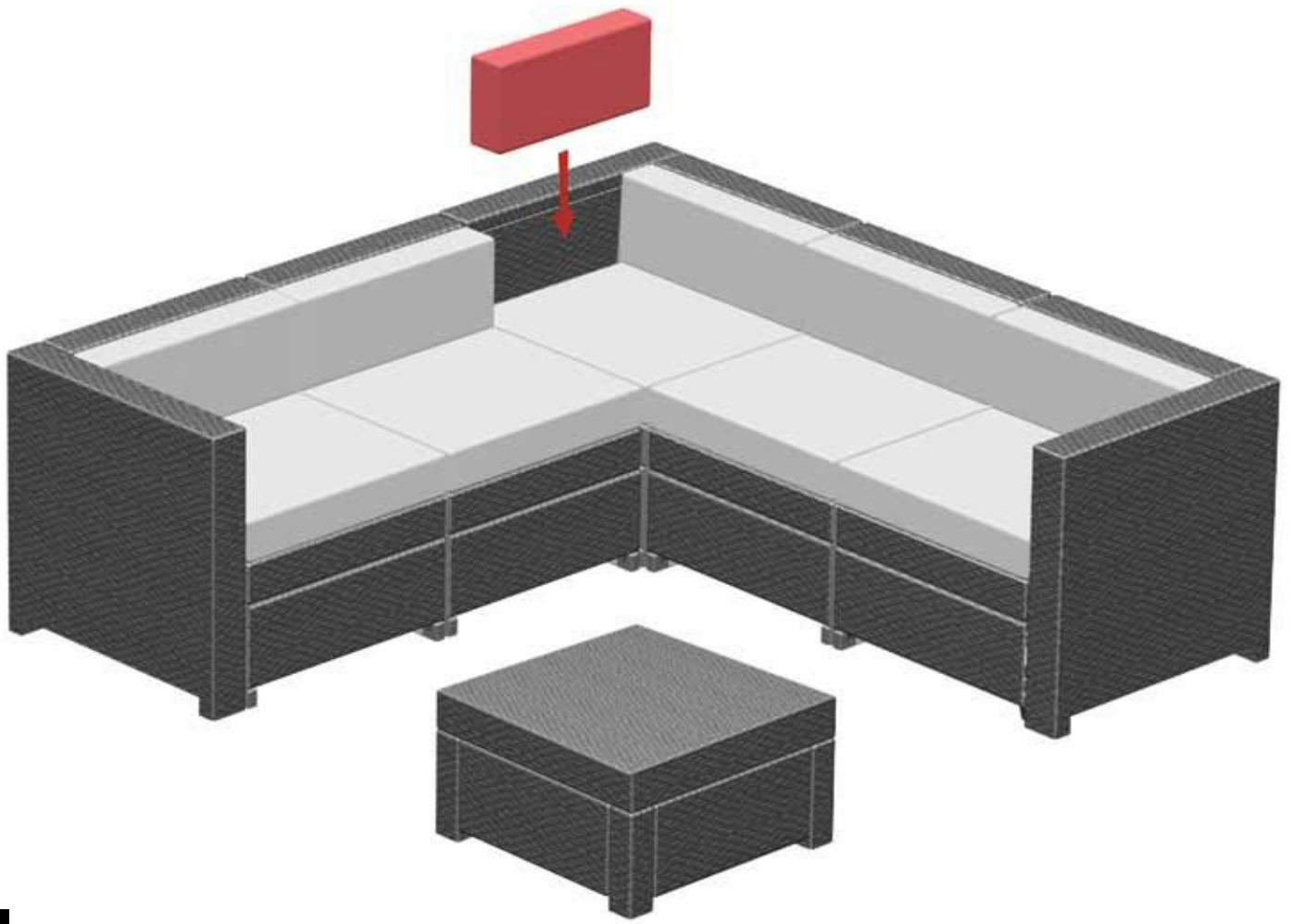

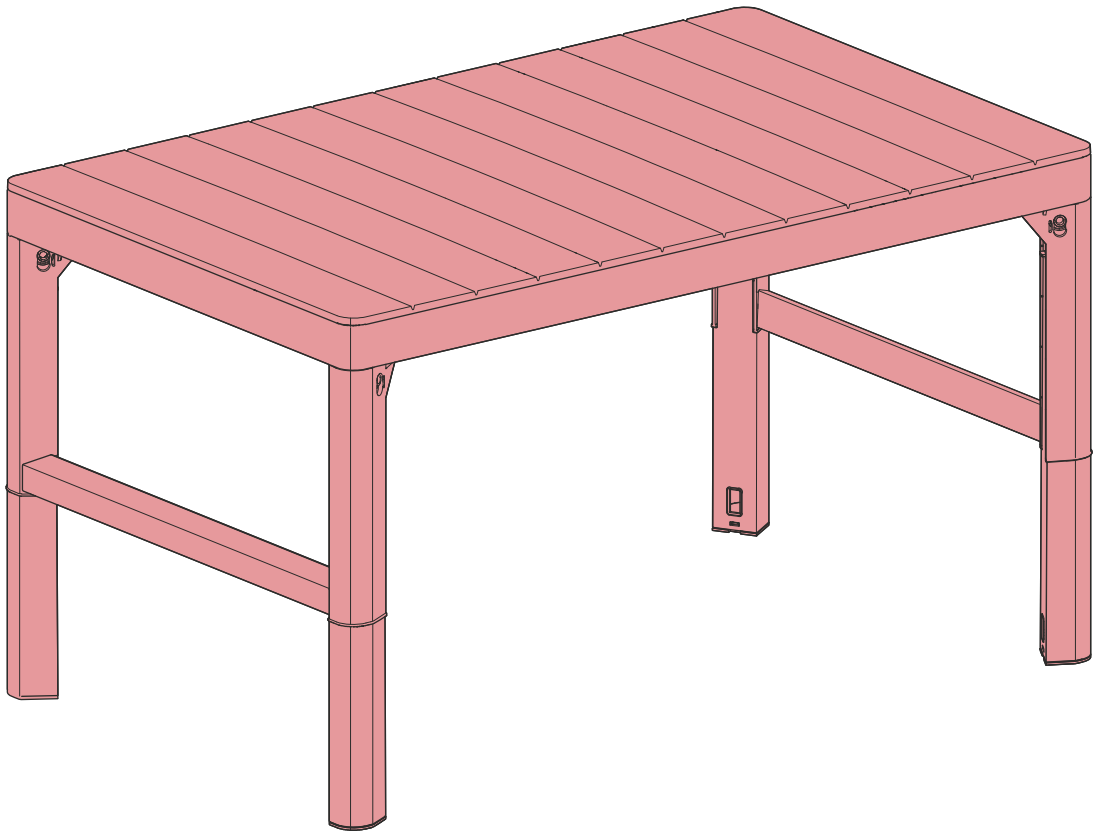
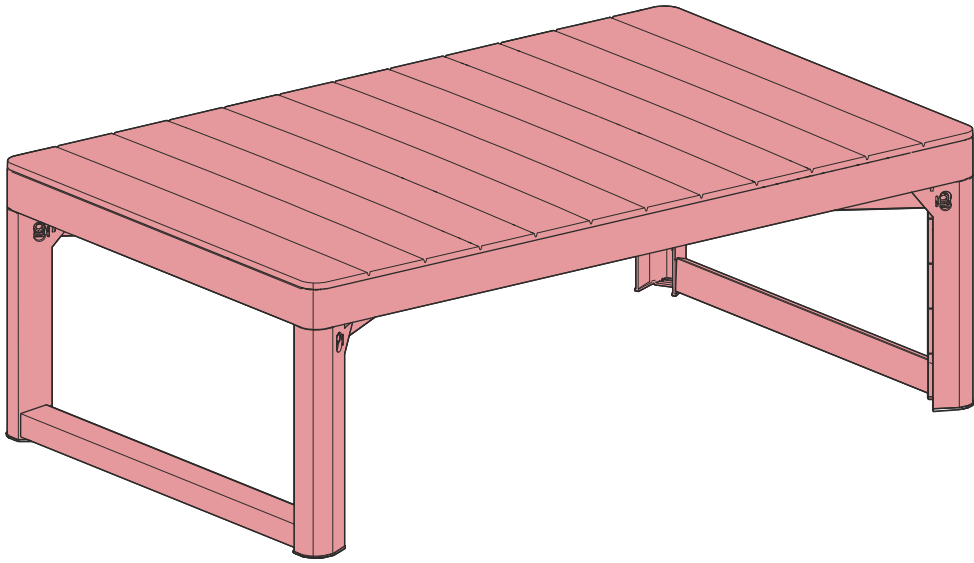

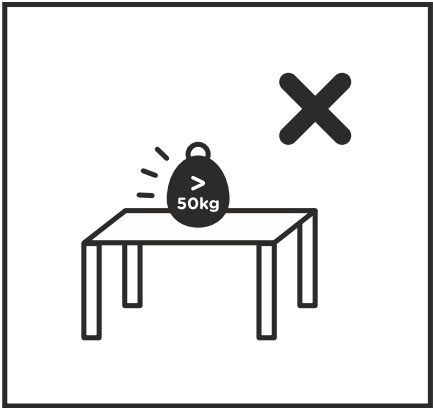
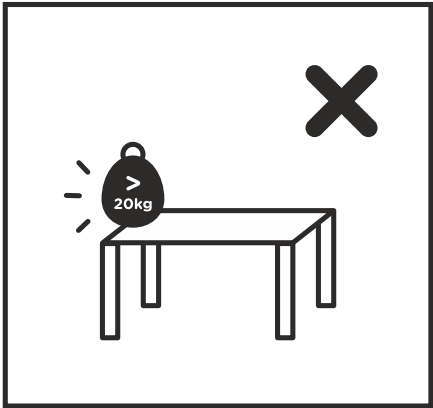
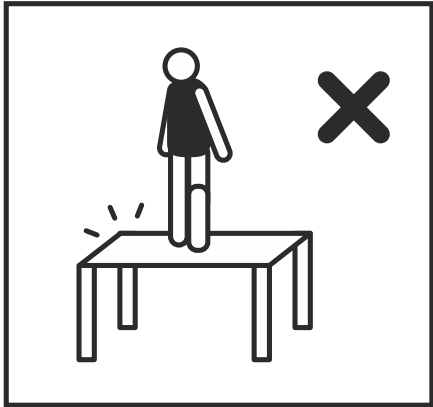
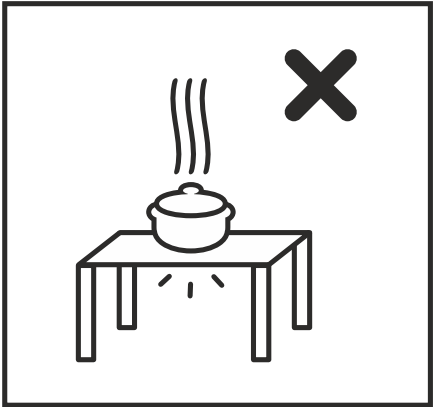
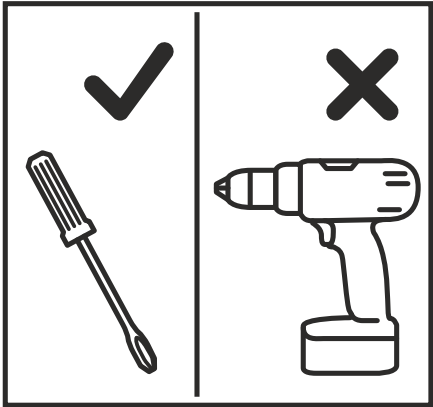
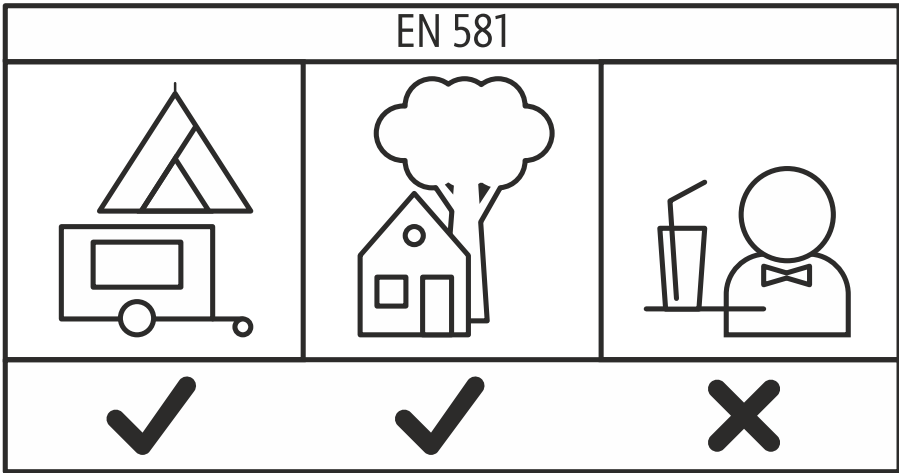
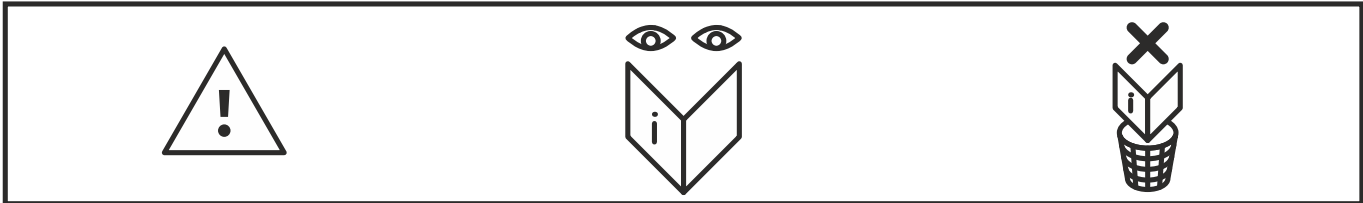

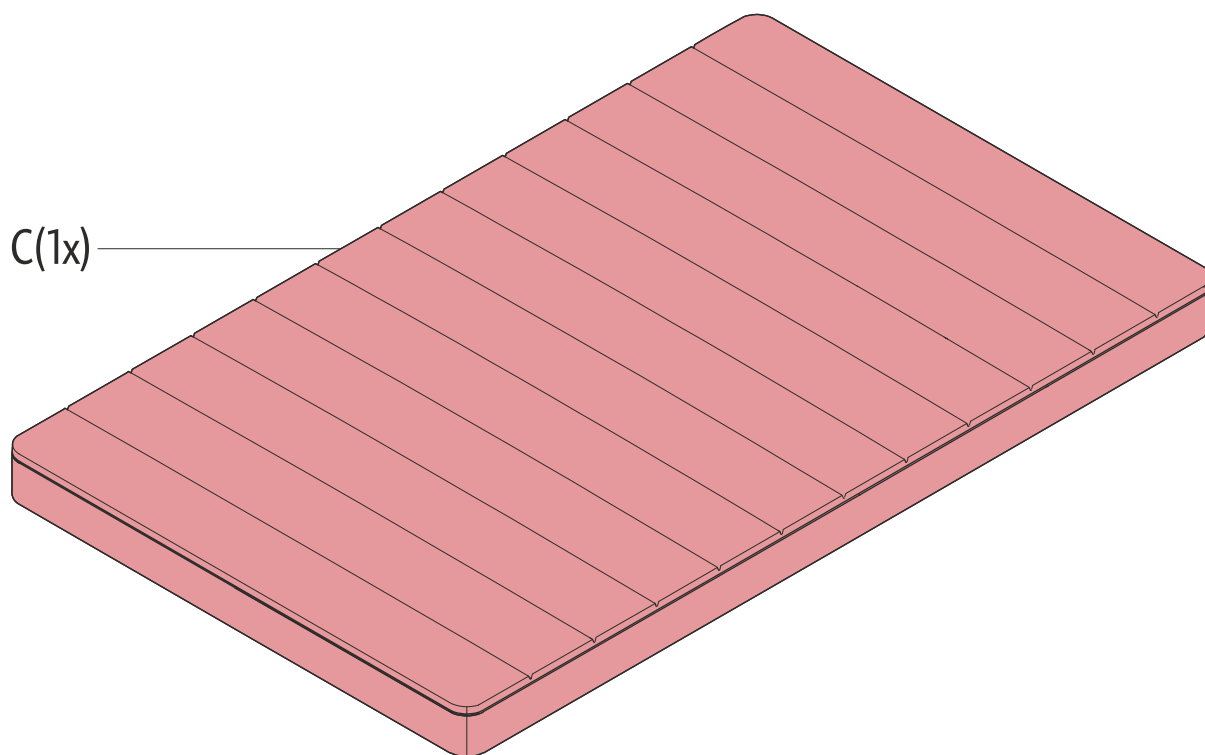
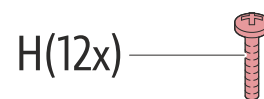
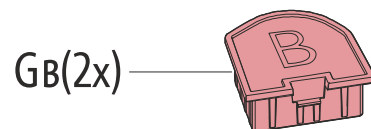
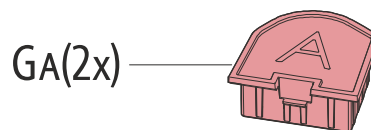
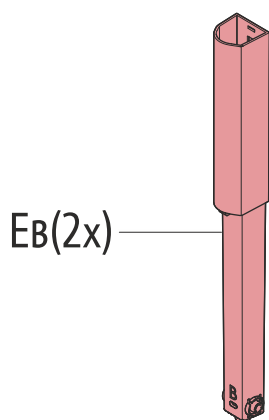
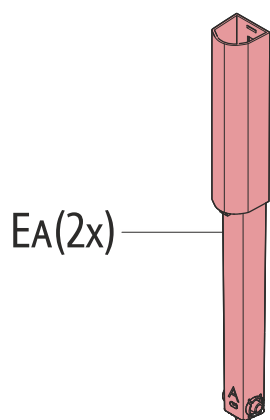
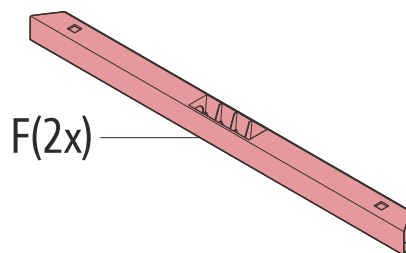
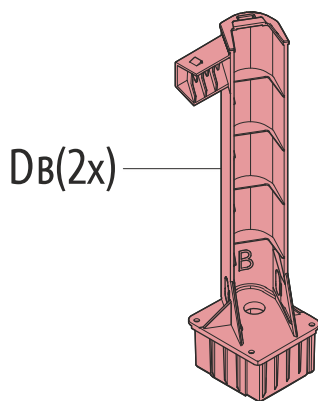
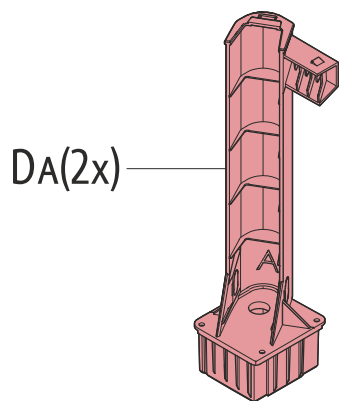

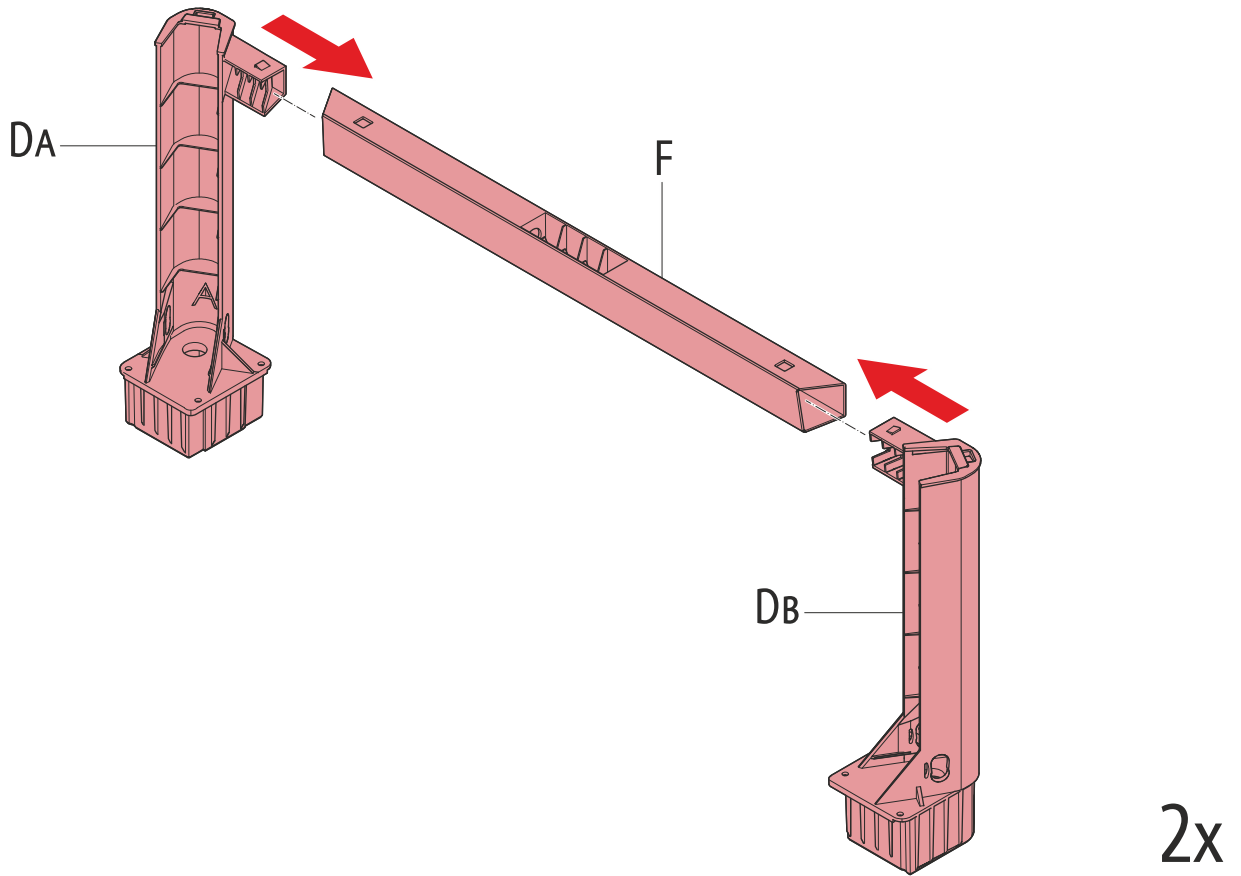

1

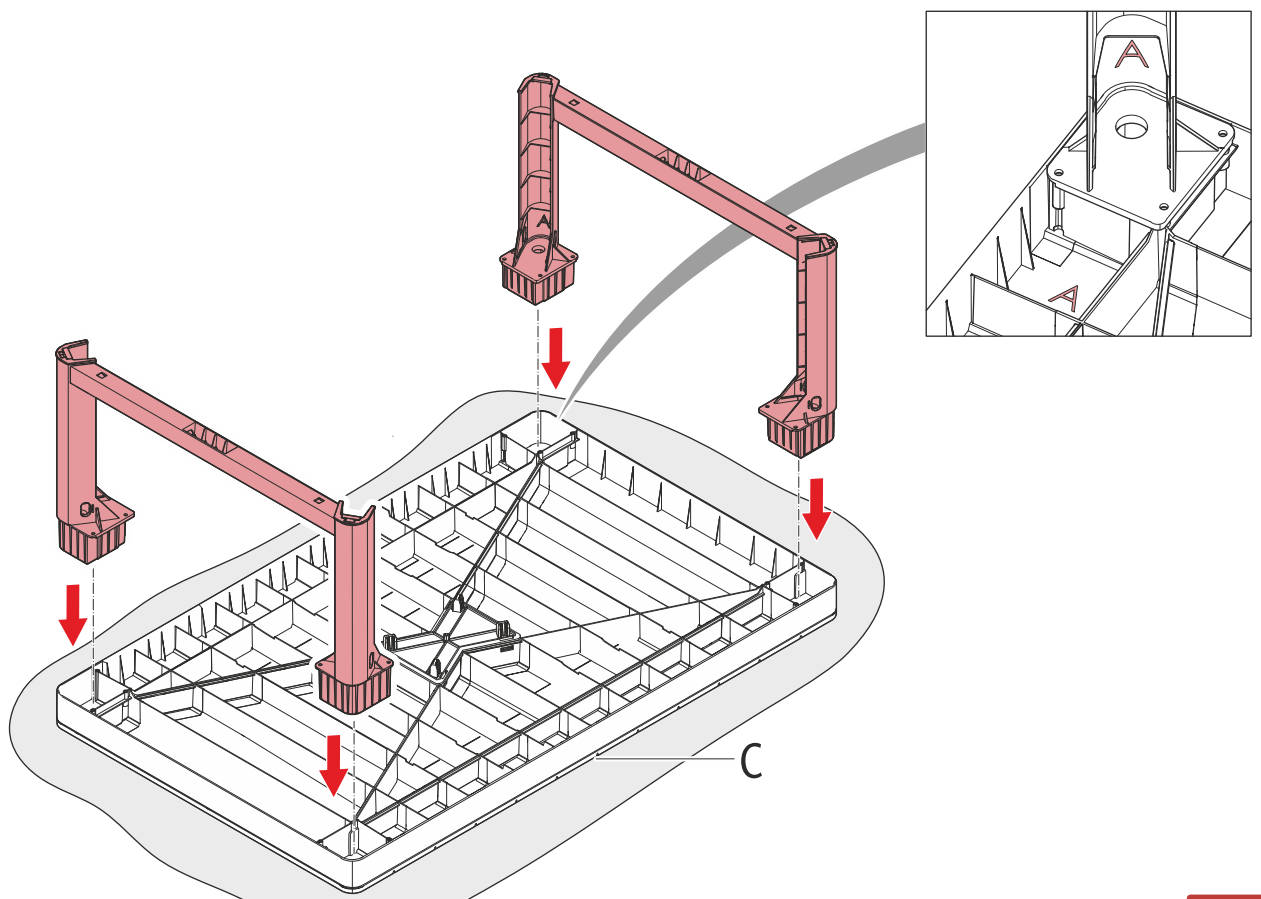

2

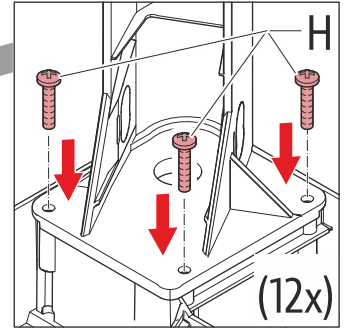
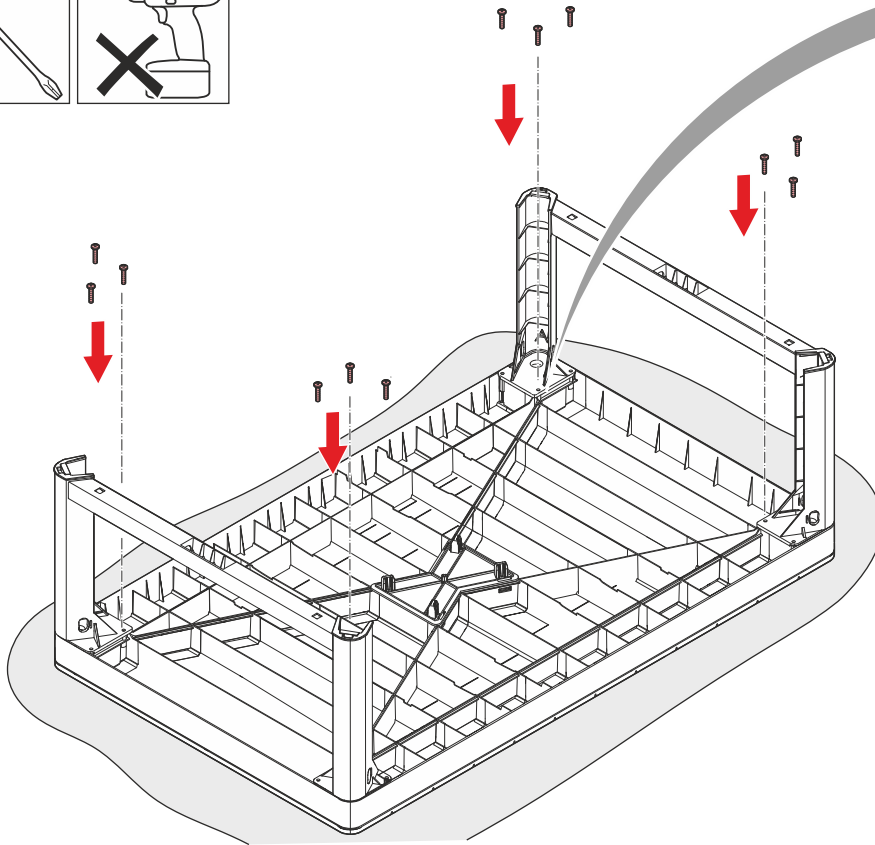
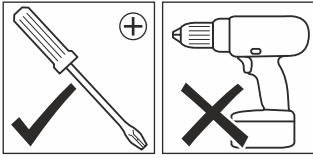

3

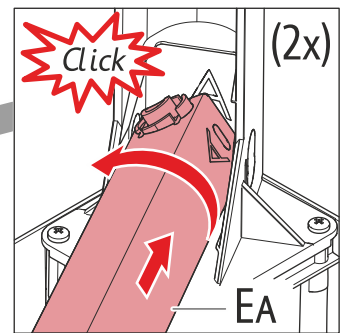
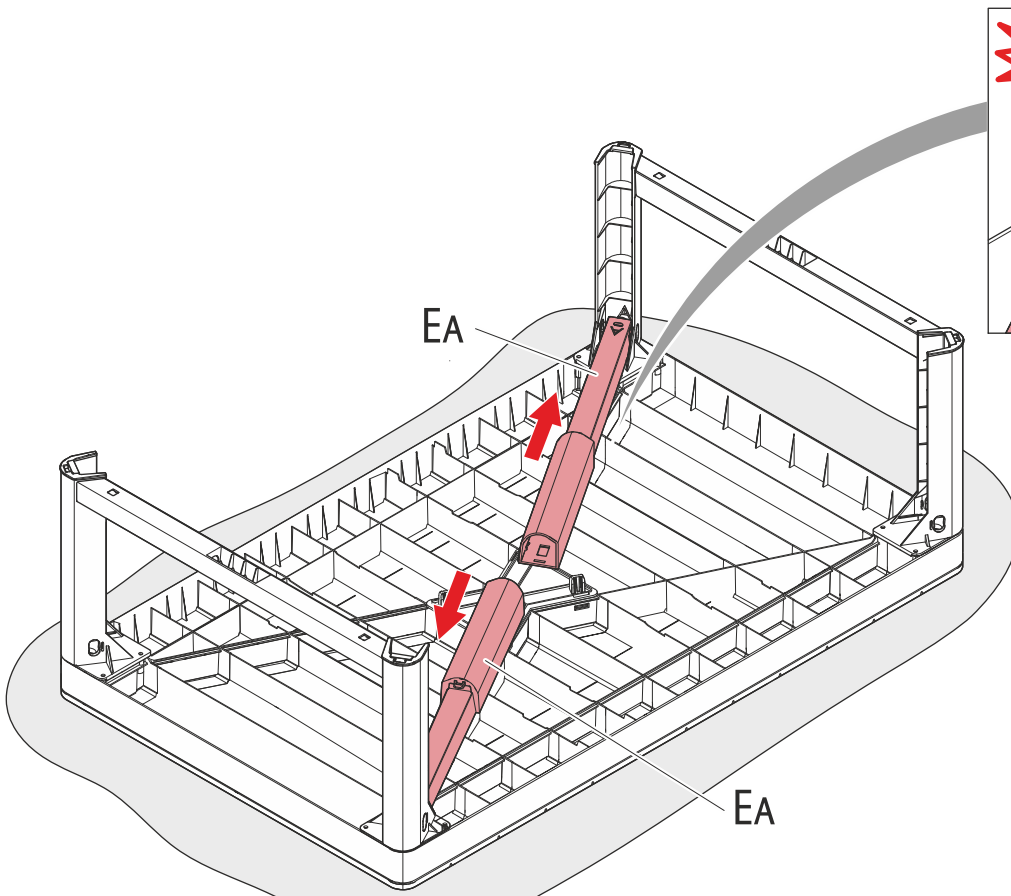

4

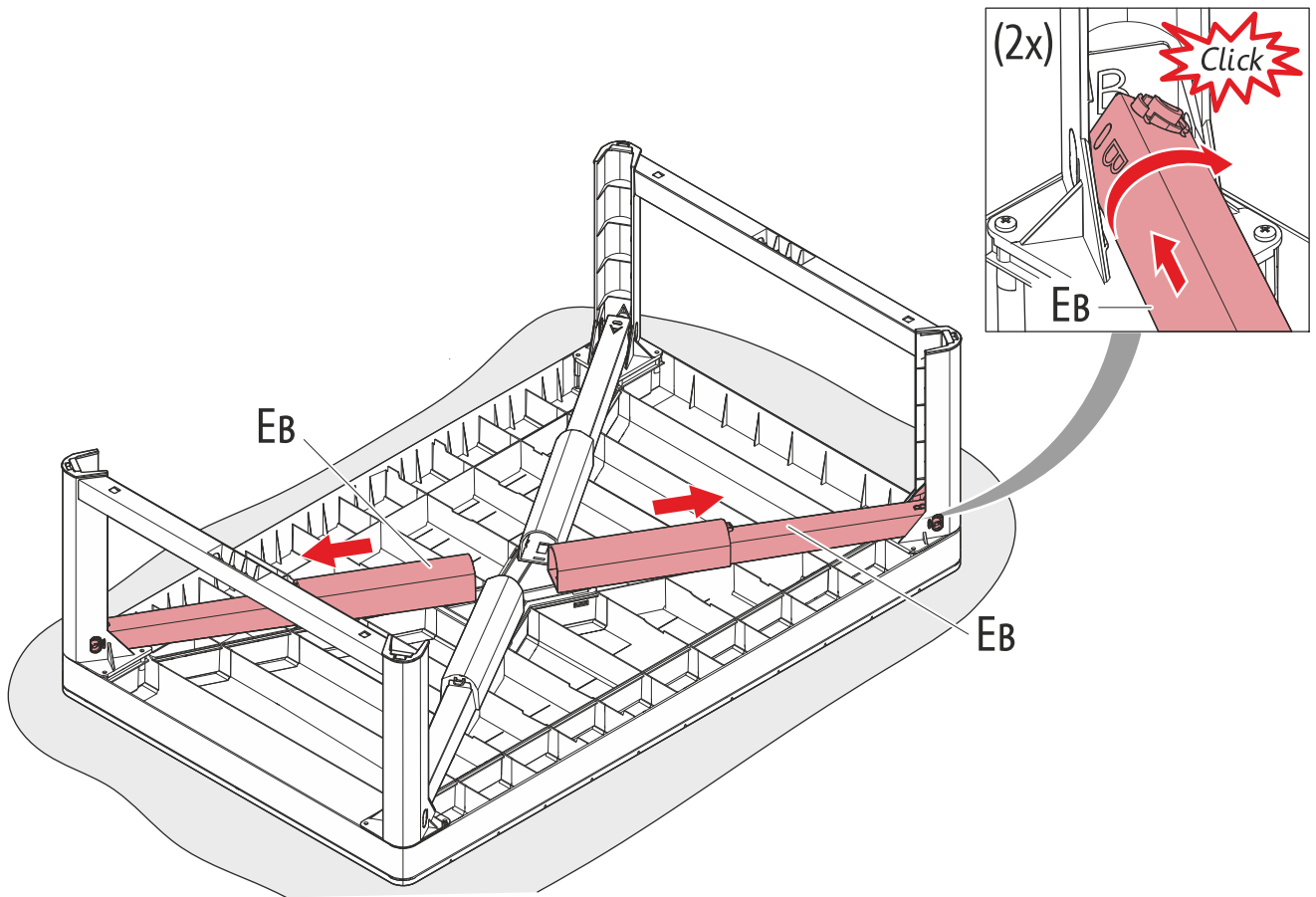

5

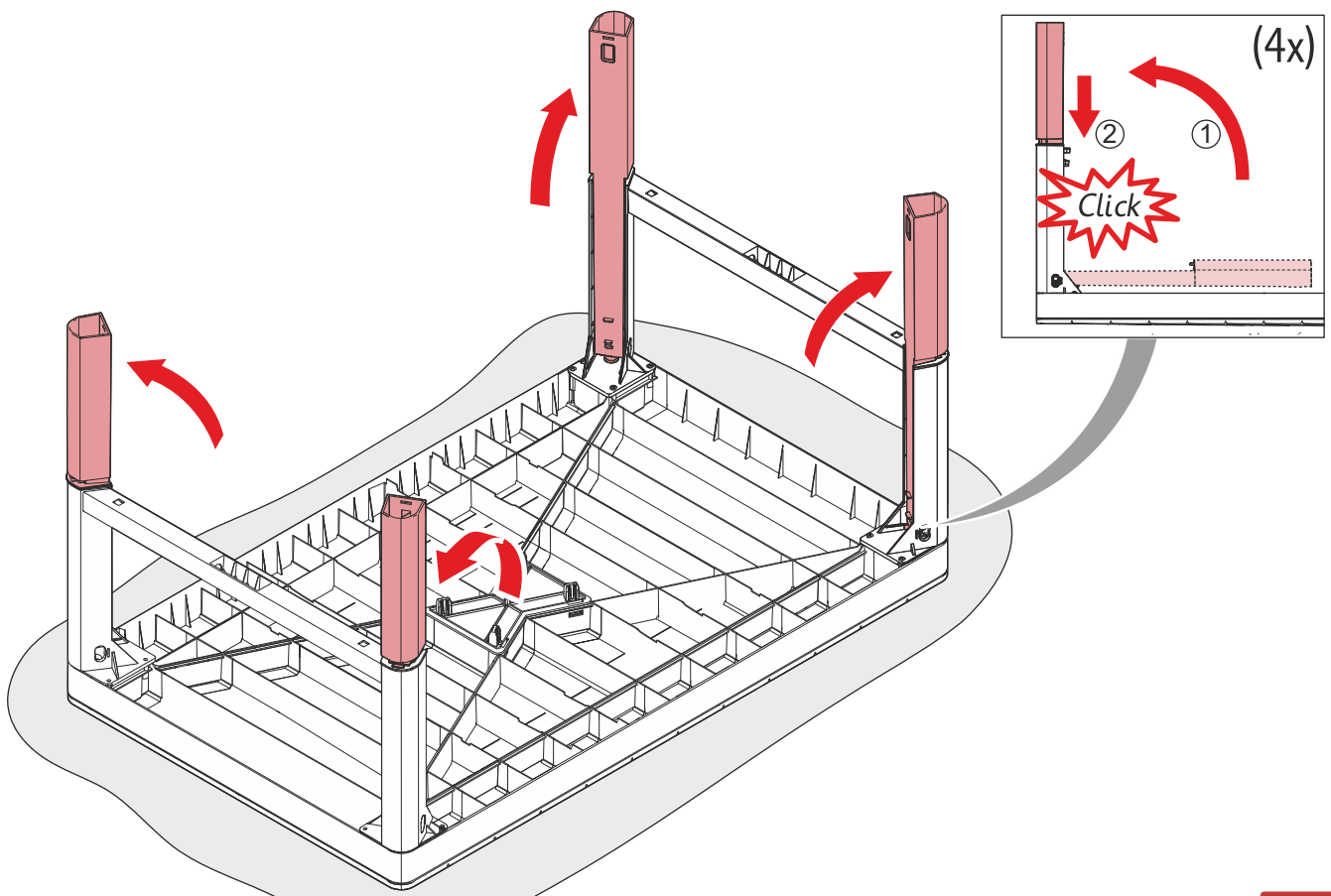

6

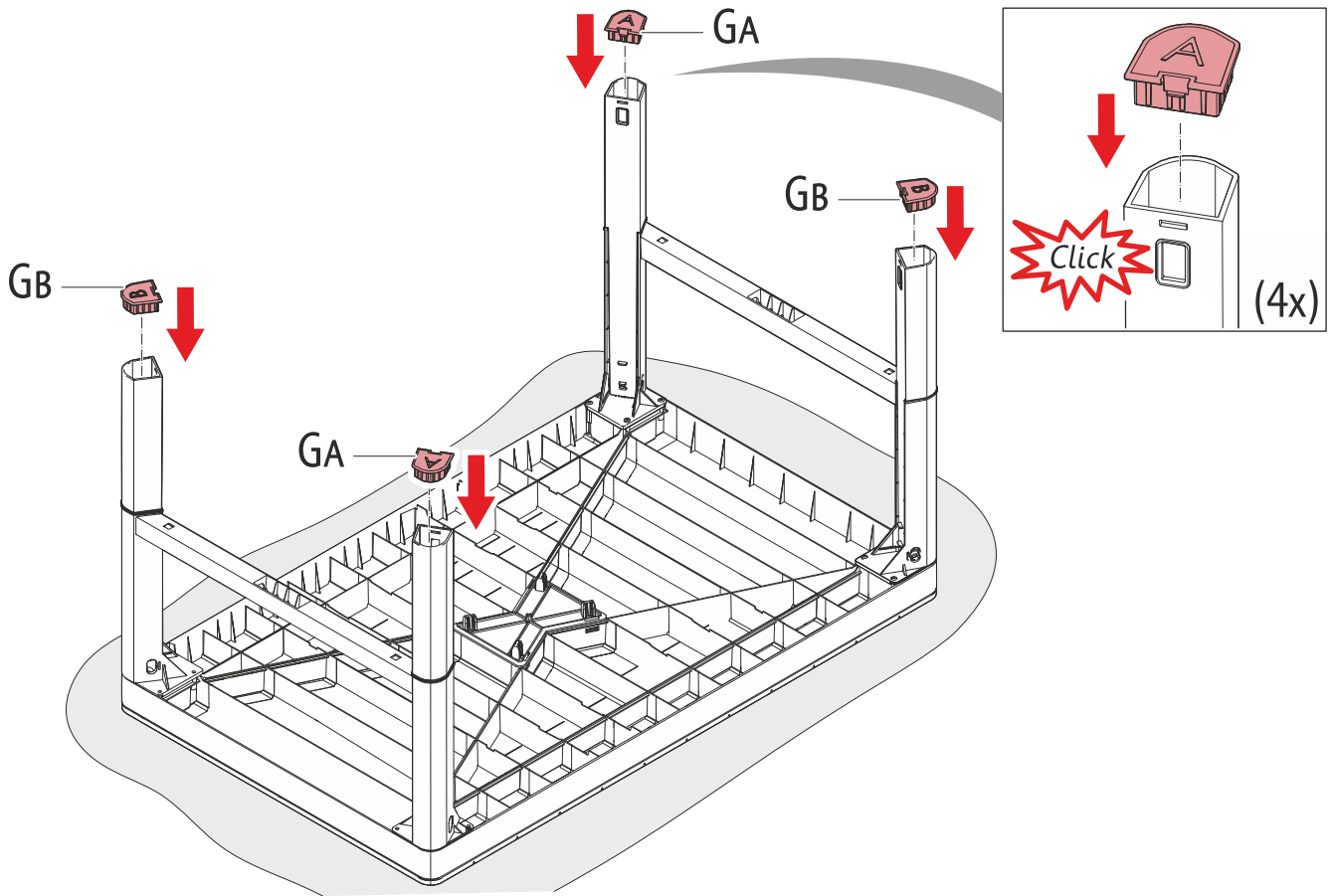

7

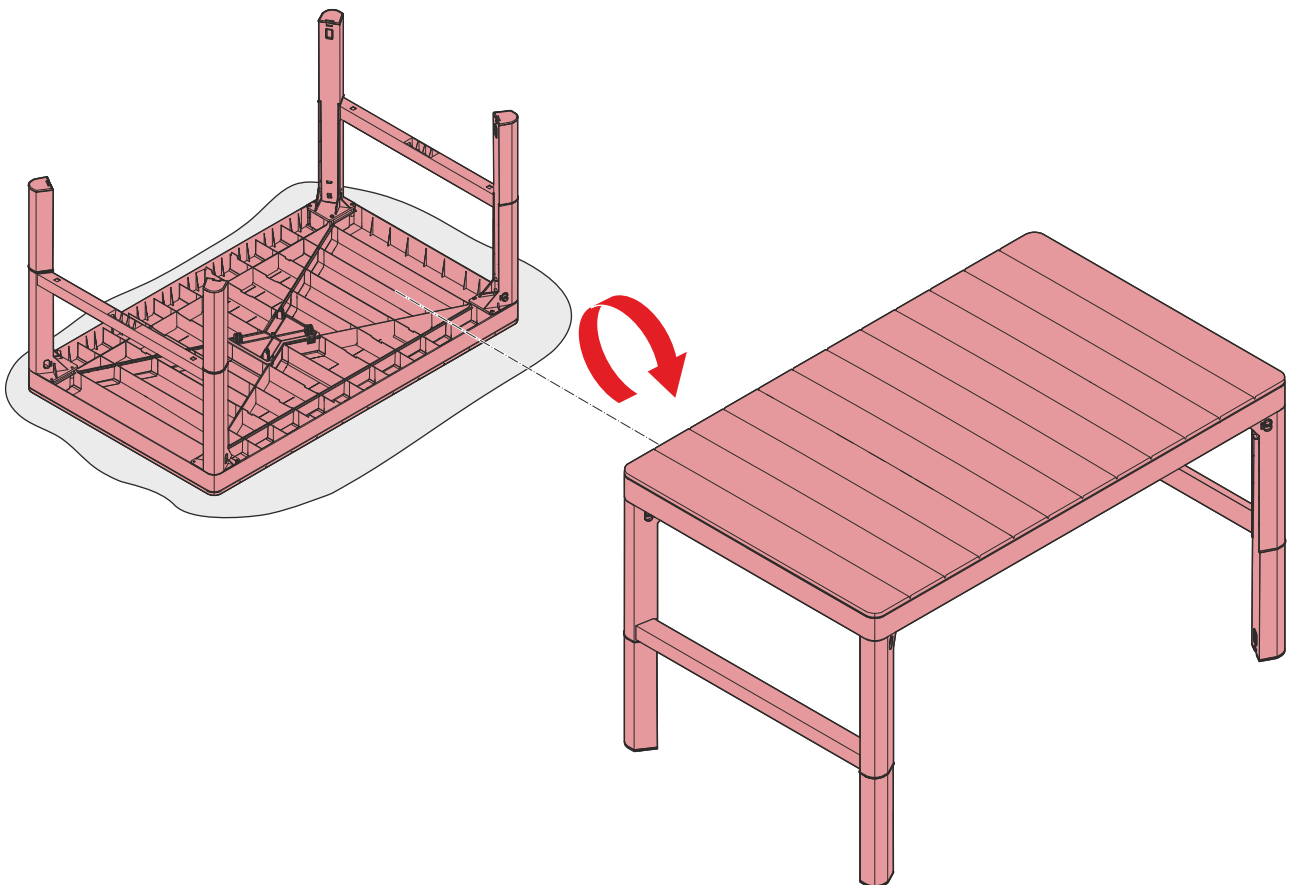

8

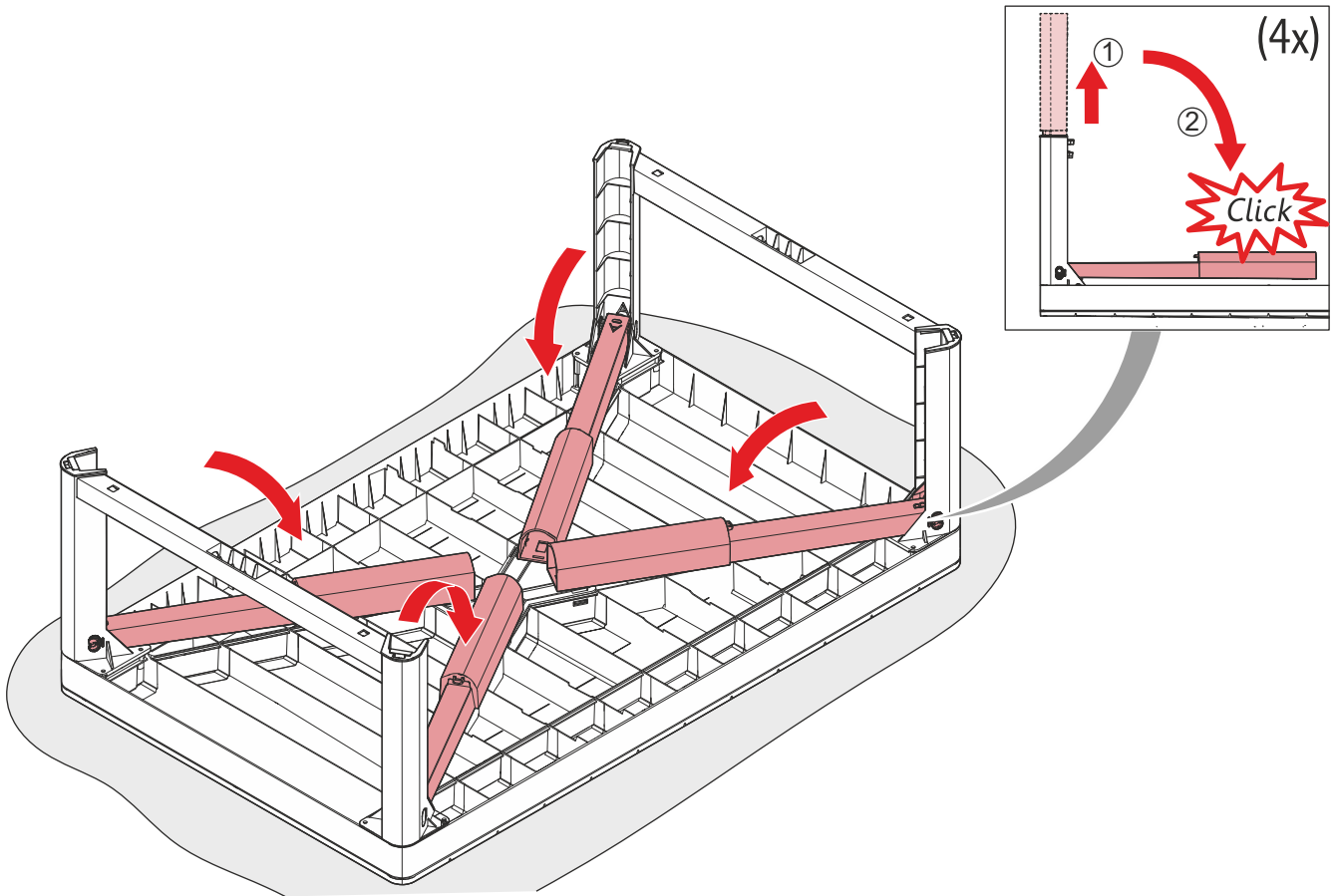

9

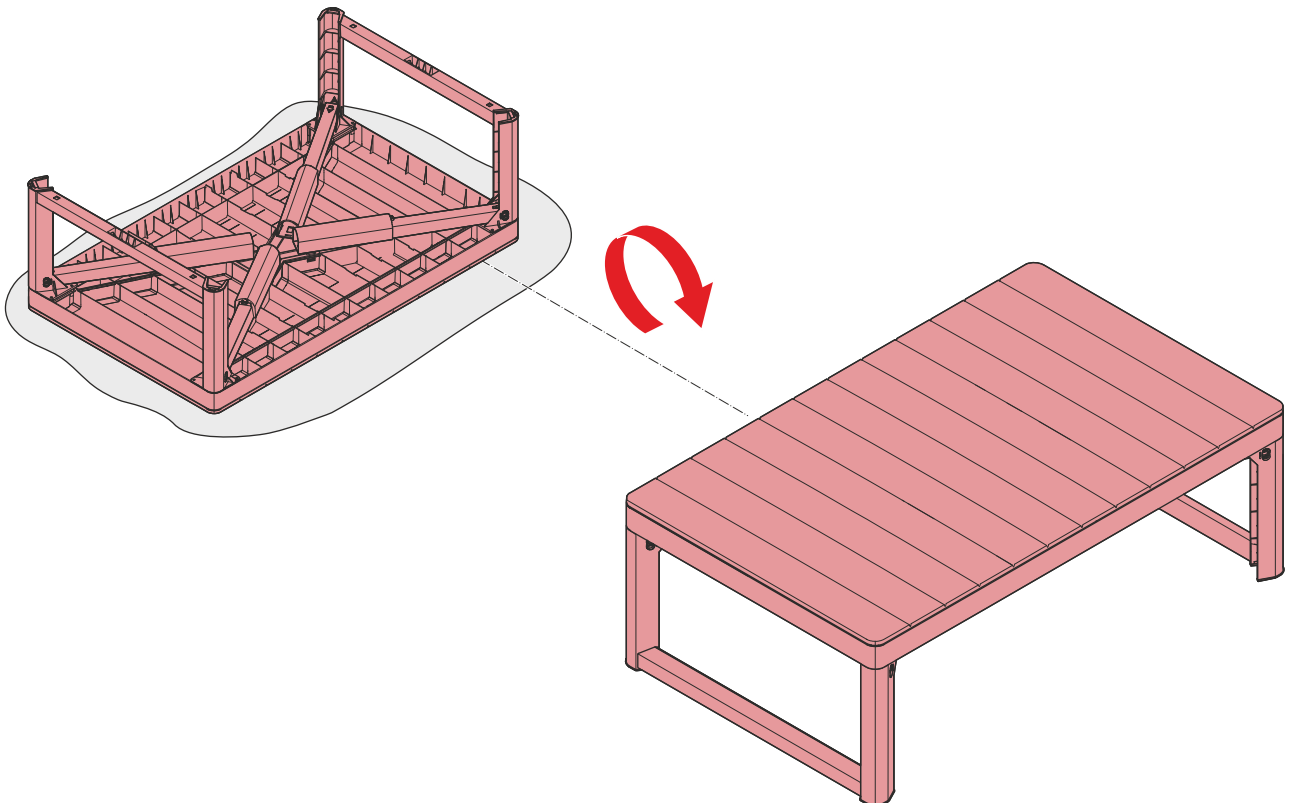

10

