

PROVENCE SET DUO KERTI BÚTOR GARNITÚRA

Instrukcja montażu | Assembly instruction | Összeszerelési útmutató | Návod k montáži |
Návod na montáž | Navodila za montažo | Instrucțiuni de montaj | Upute za montažu |
Uputstvo za montažu | Montavimo instrukcija | Montāžas instrukcija | Kokkupanekujuhend |
Посібник по монтажу | Руководство по монтажу

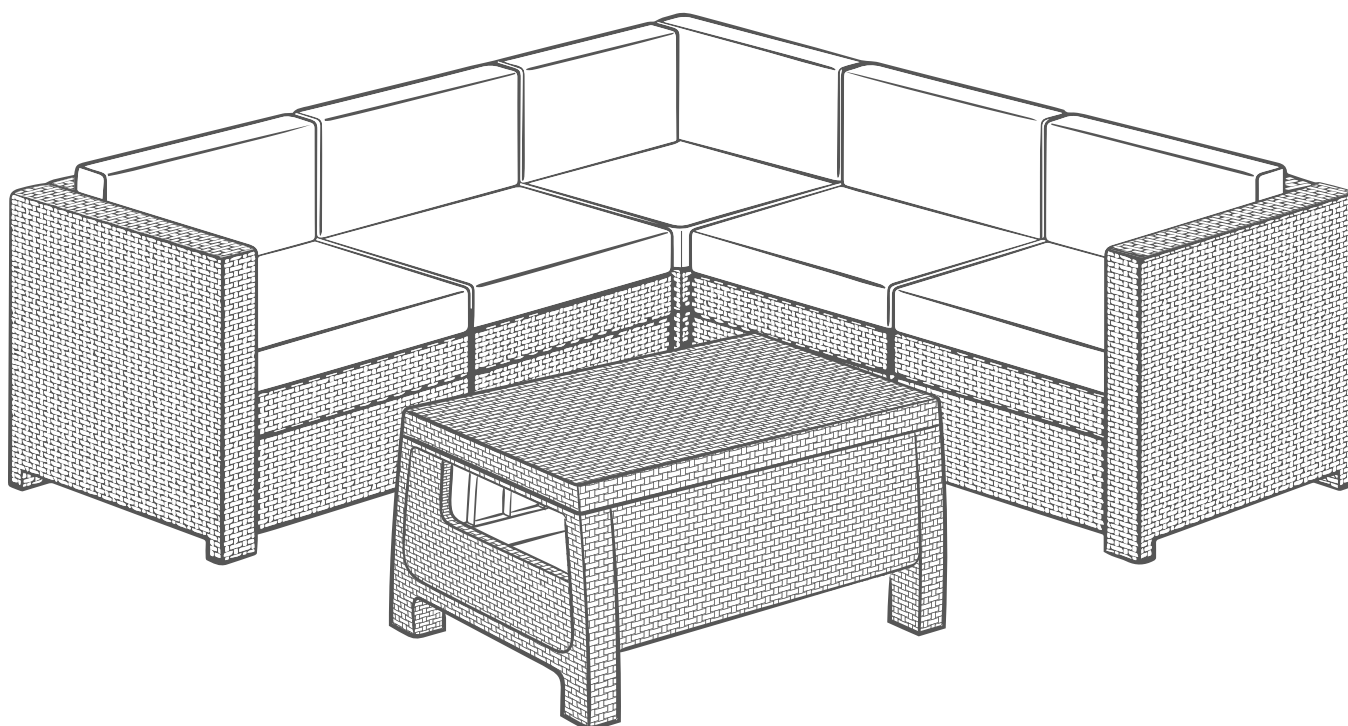

Ważne! Zachować do późniejszego stosowania. | Important! Retain for future reference |
Fontos! Kerjük megőrizni későbbi felhasználás céljából. | Důležité! Zadržet pro pozdější
použití. | Doležite! Uschovajte pre budúce použitie | Pomembno. Shranite za uporabo
v prihodnosti. | Important! Patrati pentru folosirea ulterioara | Važno! Sačuvati za upotrebu u
budućnosti. | Važno! Sačuvajte za kasnije korišćenje. | Svarbu! Išsaugoti vėlesniam
naudojimui | Svarīgi! Saglabāt turpmākai lietošanai | Таhtis! Hoidke alles hilisemaks
kasutuseks. | Важливо! Зберегти для подальшого використання. | Важно! Сохранить
для дальнейшего использования.

- PL ⚠ Uwagi i ostrzeżenia – należy przeczytać przed montażem.
- EN ⚠ Notes and warnings – please read carefully prior to assembly.
- HU ⚠ Megjegyzések és figyelmeztetések – összeszerelés előtt figyelmesen elolvasni.
- CZ ⚠ Upozornění a výstrahy – přečtěte si před montáží.
- SK ⚠ Upozornenia a výstrahy – prečítajte si pred montážou.
- SLO ⚠ Opombe in opozorila – preberite pred montažo.
- RO ⚠ Observații și avertizări – trebuie să citiți înainte de montare.
- HR ⚠ Napomene i upozorenja – pročitati prije početka montaže.
- SRB ⚠ Napomene i upozorenja – pročitati pred početak montaže.
- LT ⚠ Pastabos ir įspėjimai – perskaityti prieš montavimą.
- LV ⚠ Piezīmes un brīdinājumi – izlasīt pirms uzstādīšanas.
- EST ⚠ Märkused ja hoiatused – lugege enne kokkupanekut hoolikalt läbi.
- UA ⚠ Зауваження та застереження – необхідно уважно ознайомитися перед початком монтажу.
- RU ⚠ Примечания и предупреждения – прочитайте внимательно перед сборкой.

- PL Wszystkie elementy mebli należy montować na płaskiej powierzchni. Elementy mebli należy czyścić przy pomocy wody z mydłem i miękkiej ściereczki. Meble przeznaczone są tylko do użytku domowego.
- EN Please assemble each piece of furniture on a flat surface. The pieces of furniture should only be cleaned using soap, water, and a soft cloth. The pieces of furniture are only intended for reasonable domestic use.
- HU A bútort sík felületen kell összeszerelni. A bútort szappanos vízzel és puha törölkendővel tisztítani. A bútort otthoni használatra szolgál.
- CZ Všechny části nábytku montujte na rovném povrchu. Části nábytku očistěte vodou s mýdlem a měkkým hadříkem. Nábytek je určen pouze pro domácí použití.
- SK Všetky časti nábytku montujte na rovnom povrchu. Časti nábytku očistite vodou s mydlom a mäkkou handričkou. Nábytok je určený len pre domáce použitie.
- SLO Vse elemente pohištva montirajte na ravni površini. Elemente pohištva čistite z vodo z dodatkom mila in mehko krpo. Pohištvo je namenjeno le uporabi doma.
- RO Toate elementele mobilei trebuie să fie montate pe suprafețe plane. Elementele mobilei trebuie să fie curățate cu ajutorul apei cu săpun și a unei cârpe moi. Mobilă este destinată numai pentru uz casnic.
- HR Sve radnje pri montaži elemenata namještaja obavljati na ravnoj površini. Elemente namještaja prebrisati vodom s dodatkom sapuna i mekanom krpicom. Namještaj je namjenjen samo za kućnu uporabu.
- SRB Sve radnje pri montaži elemenata nameštaja obavljati na ravnoj površini. Elemente nameštaja prebrisati vodom sa dodatkom sapuna i mekanom krpicom. Nameštaj je namenjen samo za kućnu upotrebu.
- LT Visus baldų elementus reikia montuoti ant plokščio paviršiaus. Baldų elementus nuvalyti vandeniu su muilu ir minkštu skudurėliu. Baldai yra skirti naudoti namuose.
- LV Mēbeļu salikšana jāveic uz plakanas virsmas. Mēbeļu elementus attīrīt ar ūdeni ar ziepēm un mīkstu lupatiņu. Mēbeles ir paredzētas lietošanai mājās apstākļos.
- EST Pange iga mööbliese kokku tasasel pinnal. Puhastage mööbliesemed ainult seebi, vee ja pehme lapiga. Mööbliesemed on mõeldud ainult mõistlikuks koduseks kasutamiseks.
- UA Усі елементи меблів потрібно монтувати на плоскій поверхні. Елементи меблів потрібно очистити м'якою ганчіркою, зволоженою у воді з милом. Меблі призначені виключно для домашнього використання.
- RU Каждую часть мебели необходимо собрать на плоской поверхности. Мебель рекомендуется чистить мылом, водой и мягкой тканью. Мебель предназначен для рационального домашнего использования.

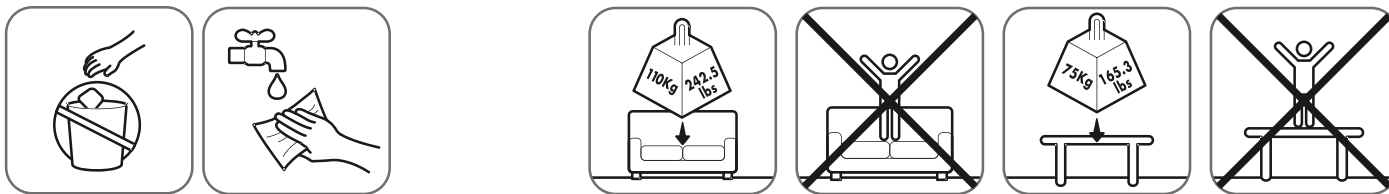

- PL W PRZYPADKU BRAKUJĄCYCH BĄDŹ ZŁAMANYCH CZĘŚCI PROSIMY NIE ZWRACAĆ PRODUKTU DO SKLEPU.
W przypadku stwierdzenia braku lub uszkodzenia części przed montażem - prosimy nie zwracać produktu, tylko skontaktować się z Działem Obsługi Klienta Dystrybutora produktu.
- EN IF THERE ARE MISSING OR BROKEN PARTS, PLEASE DO NOT RETURN THE PRODUCT TO THE STORE.
In case of any missing or damaged parts before assembly - please do not return the product just contact Distributors Customer Service.
- HU HIÁNYZÓ VAGY TÖRÖTT ELEM EK ESETÉN KÉRJÜK NE KÜLDJE VISSZA A TERMÉKET AZ ÜZLETBE.
Amennyiben hiányzó vagy sérült elemet észlel az összeszerelés előtt – kérjük, ne küldje vissza a terméket, hanem lépjen kapcsolatba a termék Forgalmazójának Ügyfélszolgálati Osztályával.
- CZ V PŘÍPADĚ CHYBĚJÍCÍCH NEBO POŠKOZENÝCH SOUČÁSTÍ PROSÍME NEVRACEJTE PRODUKT DO OBCHODU.
Pokud zjistíte poškozené či chybějící díly ještě před montáží, produkt nevracejte, ale obraťte se na zákaznické oddělení distributora produktu.
- SK V PRÍPADE CHÝBAJÚCICH ALEBO POŠKODENÝCH SÚČASŤÍ PROSÍME NEVRACAJTE PRODUKT DO OBCHODU. V prípade zistenia absencie alebo poškodenia dielu pred montážou - produkt prosím nevracajte, iba kontaktujte oddelenie starostlivosti o zákazníkov distribútora produktu.
- SLO V PRIMERU, ČE NI VSEH DELOV OZIROMA SO DELI POLOMLJENI, PROSIMO, DA NE VRAČATE IZDELKA V TRGOVINO.
Če pred montažo ugotovite, da neki elementi manjkajo oziroma so poškodovani, prosimo, da se obrnete na Oddelek za storitve za stranke Distributerja izdelka, ne pa izdelek vrnete.
- RO DACĂ SÎNT PIESE CARE LIPSESC SAU CARE SÎNT RUPTE VĂ ROG SĂ NU RETURNAȚI PRODUSUL LA MAGAZINUL.
În cazul în care se constată lipsa sau defectarea unei piese înainte de montaj, vă rugăm să nu returnați produsul ci să luați legătura cu Departamentul de Relații cu Clienții al distribuitorului produsului.
- HR U SLUČAJU NEDOSTATKA ILI SLOMLJENIH DIJELOVA, MOLIMO NEMOJTE VRATITI PROIZVOD U TRGOVINU. U slučaju nestalog dijela ili oštećenja nekog dijela prije montaže, nemojte vratiti proizvod, samo kontaktirajte Službu za korisnike distributera proizvoda.
- SRB U SLUČAJU AKO NE DOSTAJU DELOVI ILI AKO SU POLOMLJENI, MOLIMO VAS NEMOJTE DA VRATITE PROIZVOD U PRODAVNICU.
Ako pre montaže konstatujete nedostatak ili oštećenje delova, molimo ne vraćajte proizvod, samo kontaktirajte Korisnički servis distributera proizvoda.
- LT DALIŲ TRŪKUMO AR SULŪŽIMO ATVEJU PRAŠOME PRODUKTO NEGRAŽINTI Į PARDUOTUVĘ.
Pastebėjus kokius nors trūkumus ar dalių pažeidimus prieš montavimą, prašome negražinti produkto, tik susisiekti su produkto platintojo Klientų aptarnavimo skyriumi.
- LV DETAĻU TRŪKUMA VAI SABOJĀTU DETAĻU GADĪJUMĀ LŪDZAM PRODUKTU NEATDOT VEIKALĀ.
Gadījumā, ja pirms montāžas tiks konstatēti detaļu defekti vai bojājumi, lūdzam produktu neatdot, tikai kontaktēties ar produkta izplatītāja Klientu Apkalpošanas Daļu.
- EST KUI AVASTATE, ET TOODE EI OLE KOMPLEKTNE VÕI ON PURUNENUD, ÄRGE SAATKE SEDA MÜÜJALE TAGASI.
Osade puudumise või kahjustuste avastamisel enne paigaldamist ärge tagastage toodet, vaid võtke ühendust toote turustaja Klienditeenindusosakonnaga.
- UA В СЛУЧАЄ ОТСУТСТВИЯ ІЛИ БРАКОВАННИХ ЧАСТЕЙ ПРОСЬБА НЕ ВОЗВРАЩАТЬ ПРОДУКТ В МАГАЗИН.
У разі виявлення дефекту або пошкодження, будь ласка, не повертайте продукт, просто зв'яжіться з Відділом обслуговування покупців дистриб'ютора продукту.
- RU В СЛУЧАЙ, ЧЕ ИМА ЛИПСВАЩИ ИЛИ СЧУПЕНИ ЧАСТИ, ВИ МОЛИМ ДА НЕ ВРЪЩАТЕ ПРОДУКТА В МАГАЗИНА.
В случае выявления дефекта или повреждения до монтажа, пожалуйста, не возвращайте продукт, просто свяжитесь с Отделом обслуживания покупателей дистрибьютора продукта.

Producent / Producer / Gyártó / Výrobce / Výrobca / Proizvajalec / Producător / Proizvođač / Proizvođač / Gamintojas / Ražotājs /
Tootja / Виробник / Производитель: CURVER Hungary, Zsong Völgy 2, H-4211 Ebes, Hungary.

Dystrybutor / Distributor / Forgalmazó / Distributor / Distribútor / Distributor / Distributor / Distributor / Platintojas /
Izplatītājs / Turustaja / Дистриб'ютор / Дистрибьютор: CURVER Poland Sp. z o. o., ul. Wrocławska 34, 76-200 Słupsk, Polska;
CURVER Hungary, Zsong Völgy 2, H-4211 Ebes, Hungary.

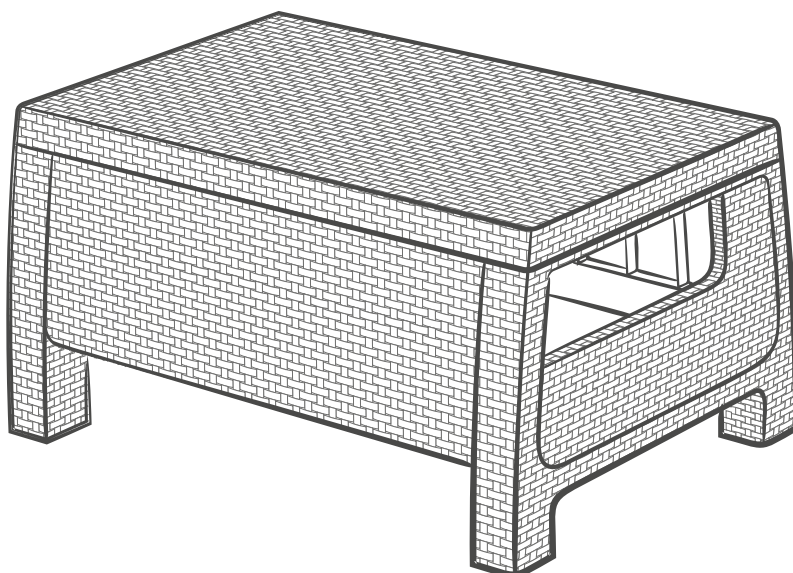

Zawartość | Contents | Tartalom | Obsah | Obsah | Vsebina | Conținut | Sadržaj | Sadržaj | Turinys | Saturs | Sisu | Комплектація | Содержание

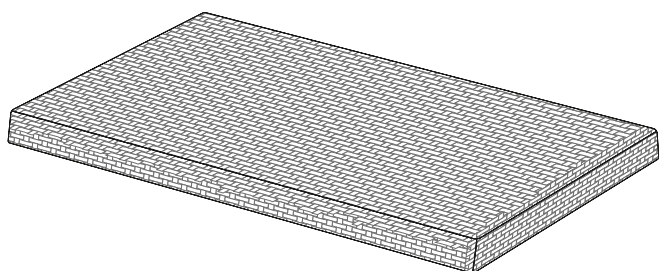

Tx1

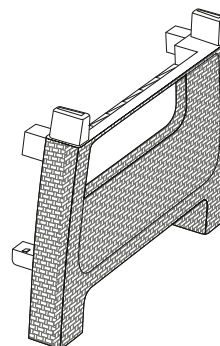

SSTx2

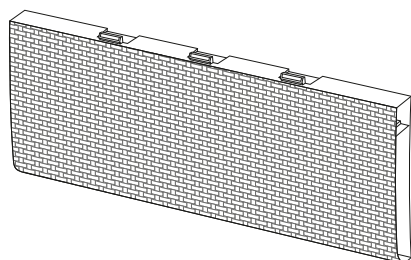

LSTx2



LPx4

1

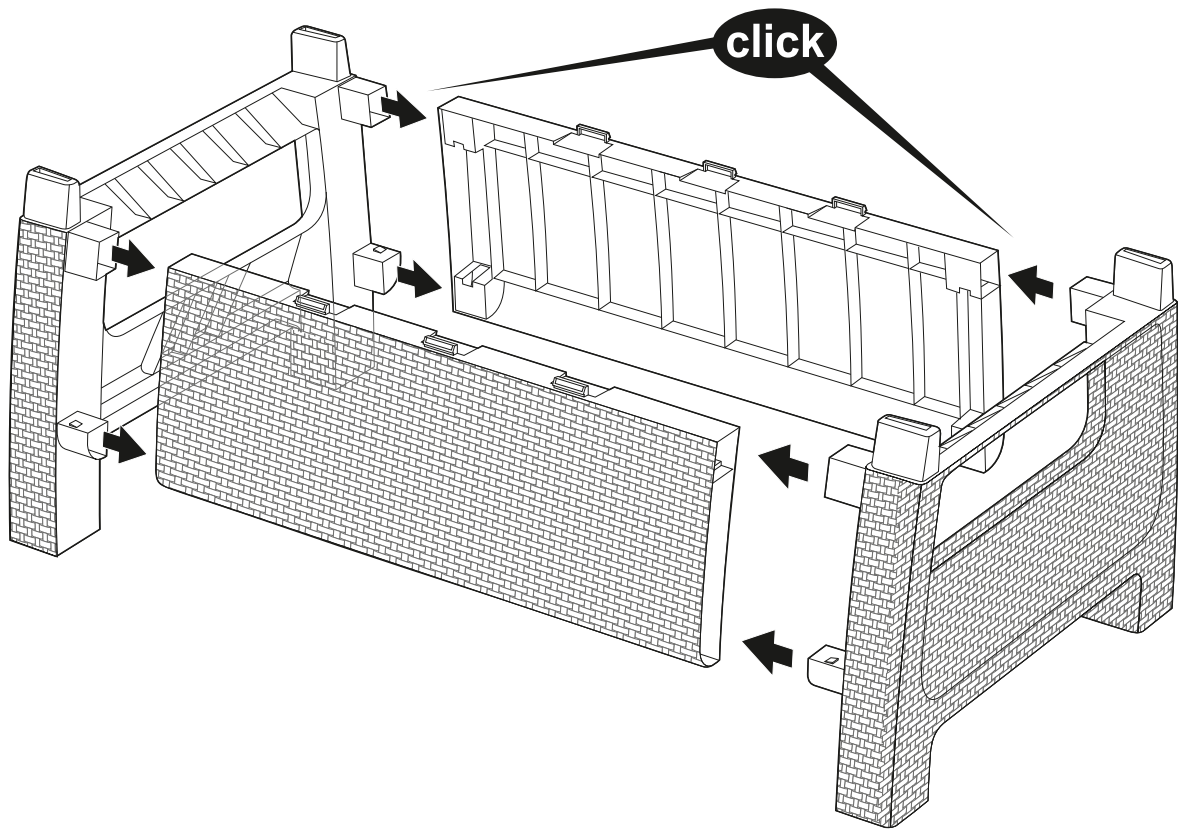

2

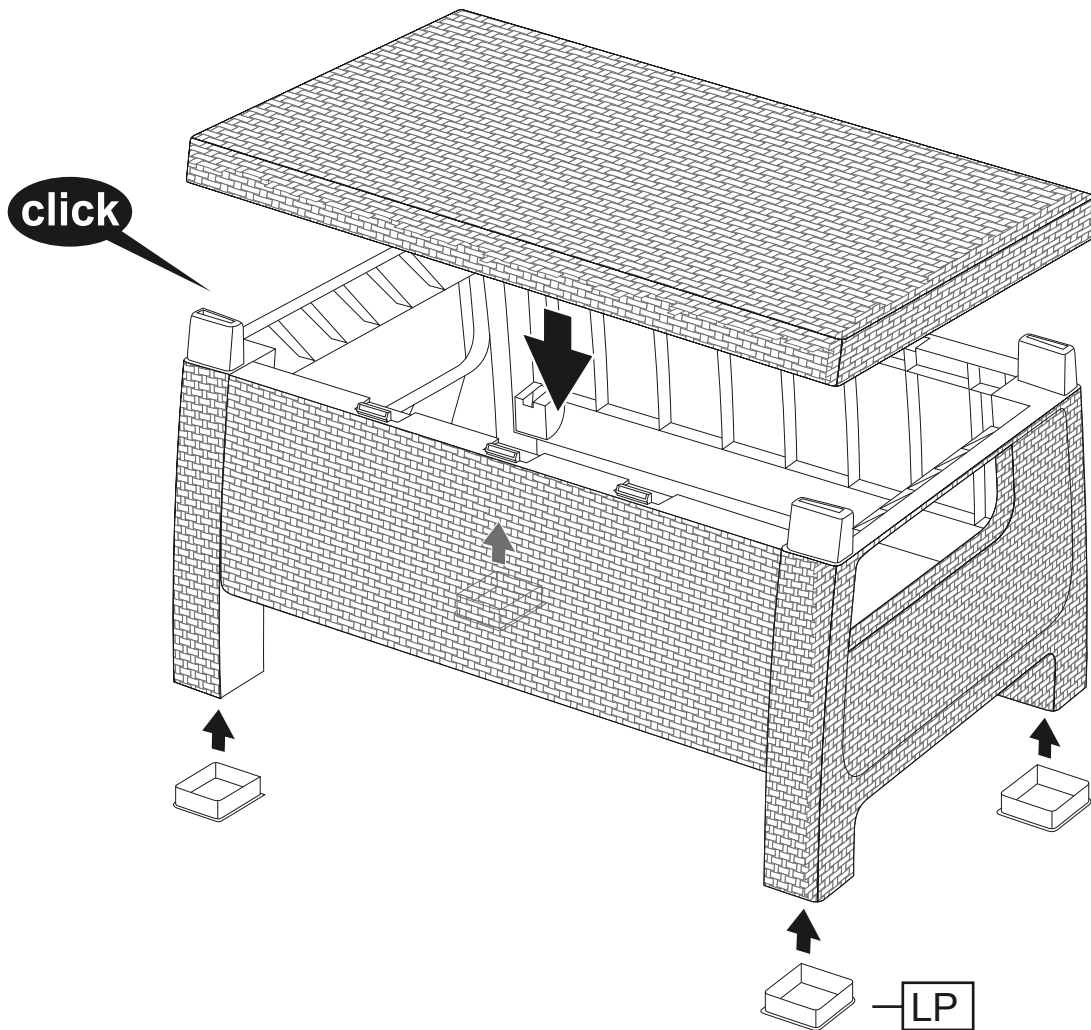
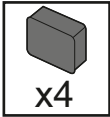



Zawartość | Contents | Tartalom | Obsah | Obsah | Vsebina | Conținut | Sadržaj | Sadržaj | Turinys | Saturs | Sisu | Комплектація | Содержание

<p>F x1</p>	<p>LS x1</p>	<p>SP x2</p>	<p>G x1</p>	
<p>PR x1</p>	<p>BC x1</p>	<p>x4</p>	<p>x1</p>	
<p>Seat x1</p>	<p>Back x1</p>	<p>x1</p>	<p>x20</p>	
<p>L x1</p>	<p>x1</p>	<p>x1</p>	<p>x18</p>	<p>x1</p>
			<p>x1</p>	<p>x2</p>

F

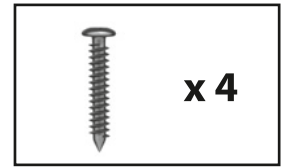
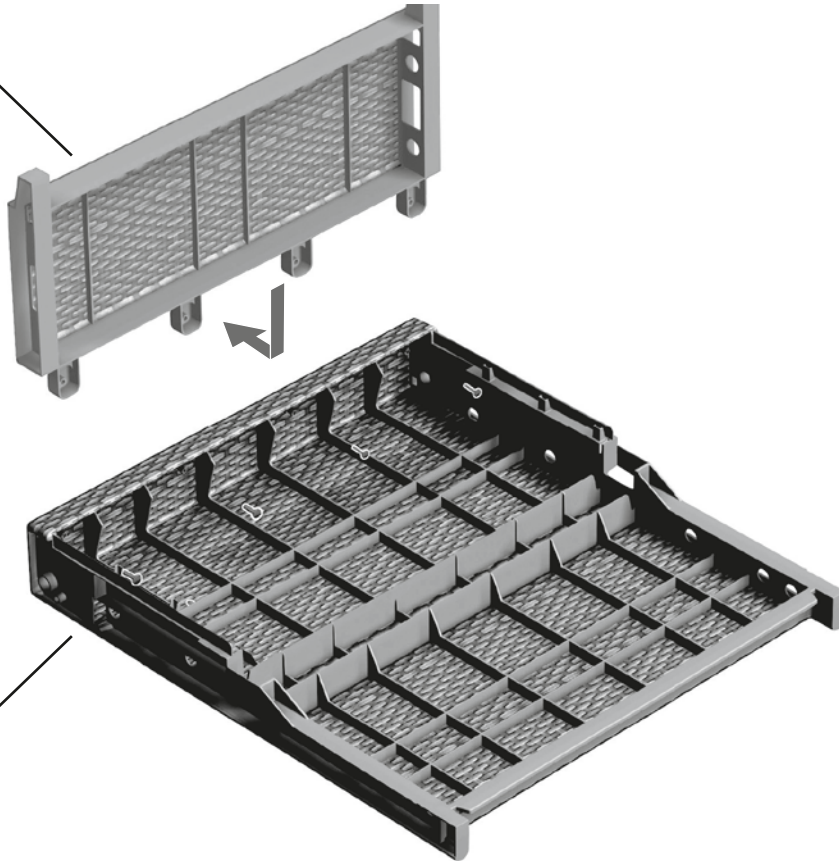

Seat

1

L

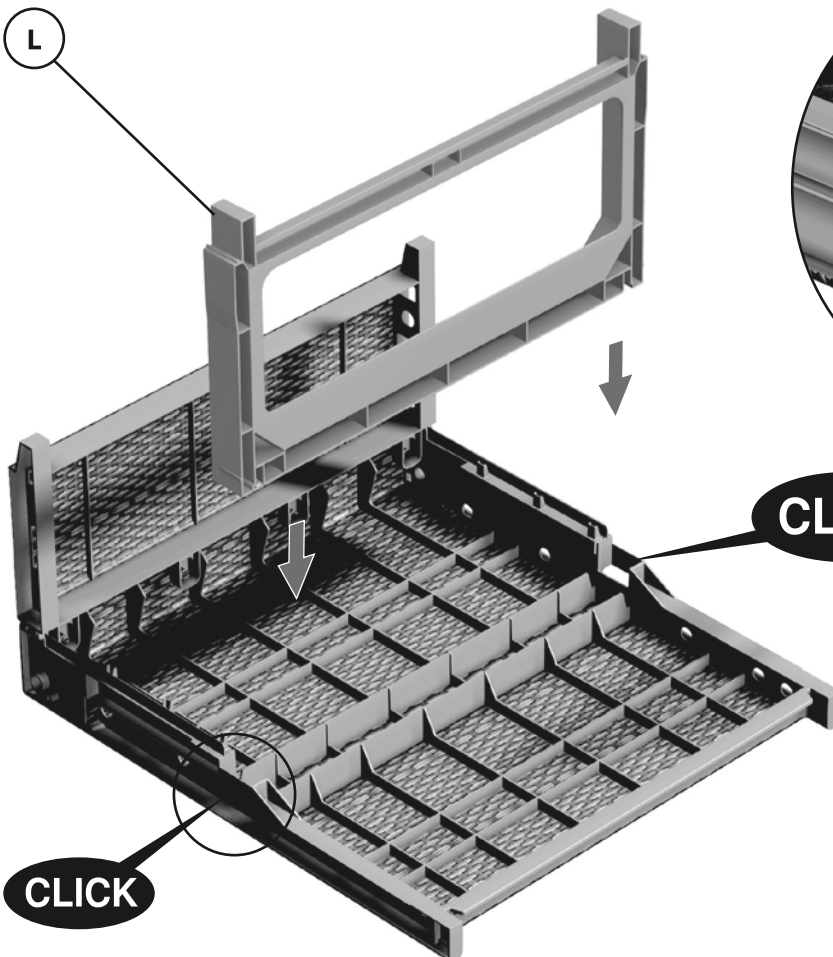

CLICK

CLICK

2

Back

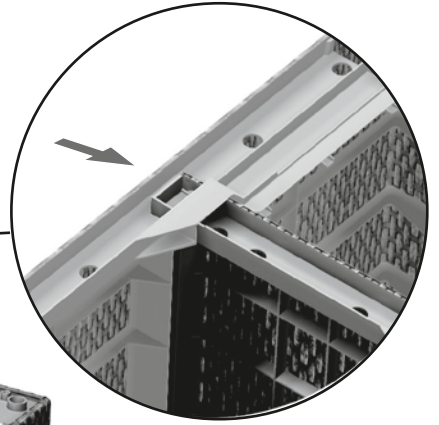
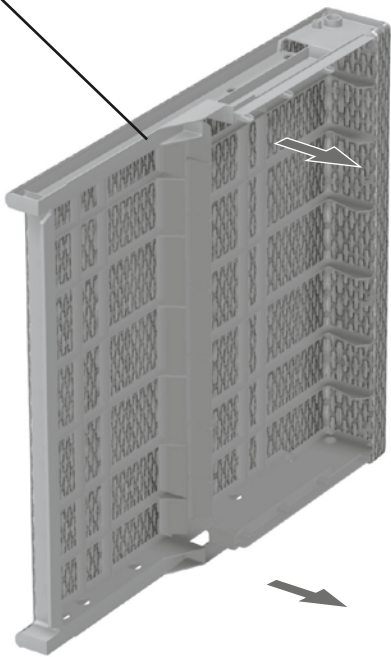

3

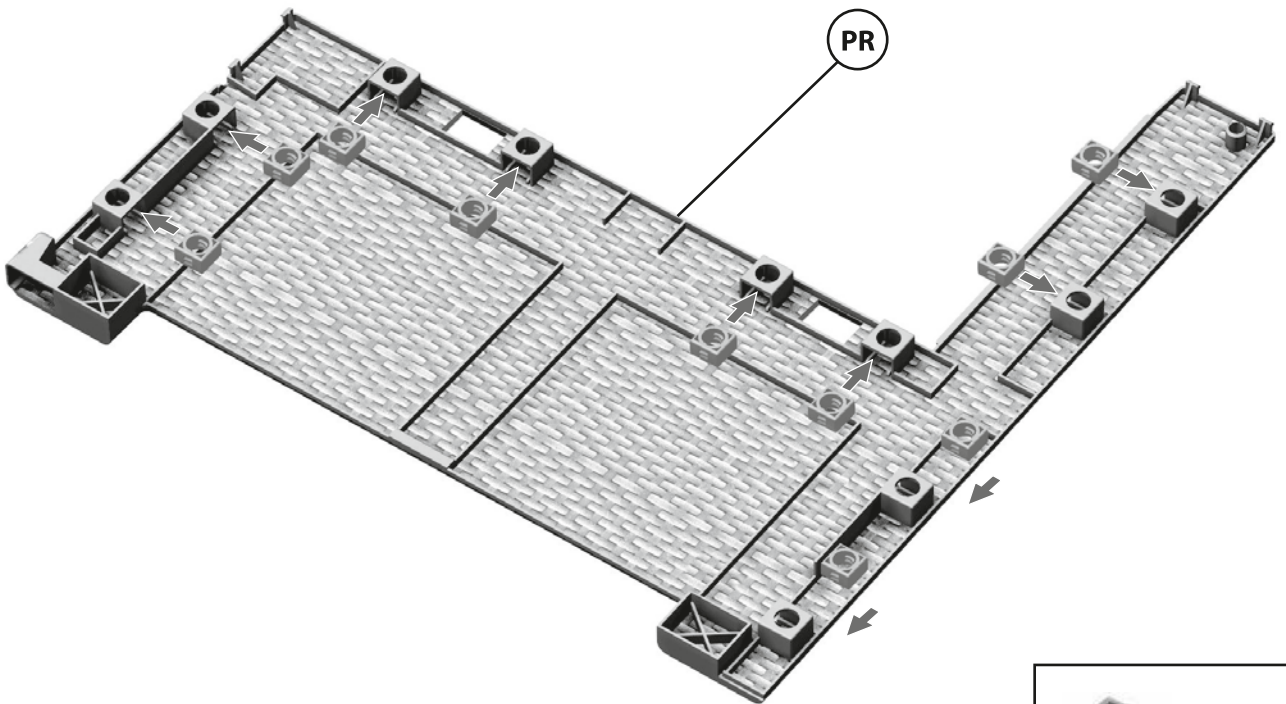

4

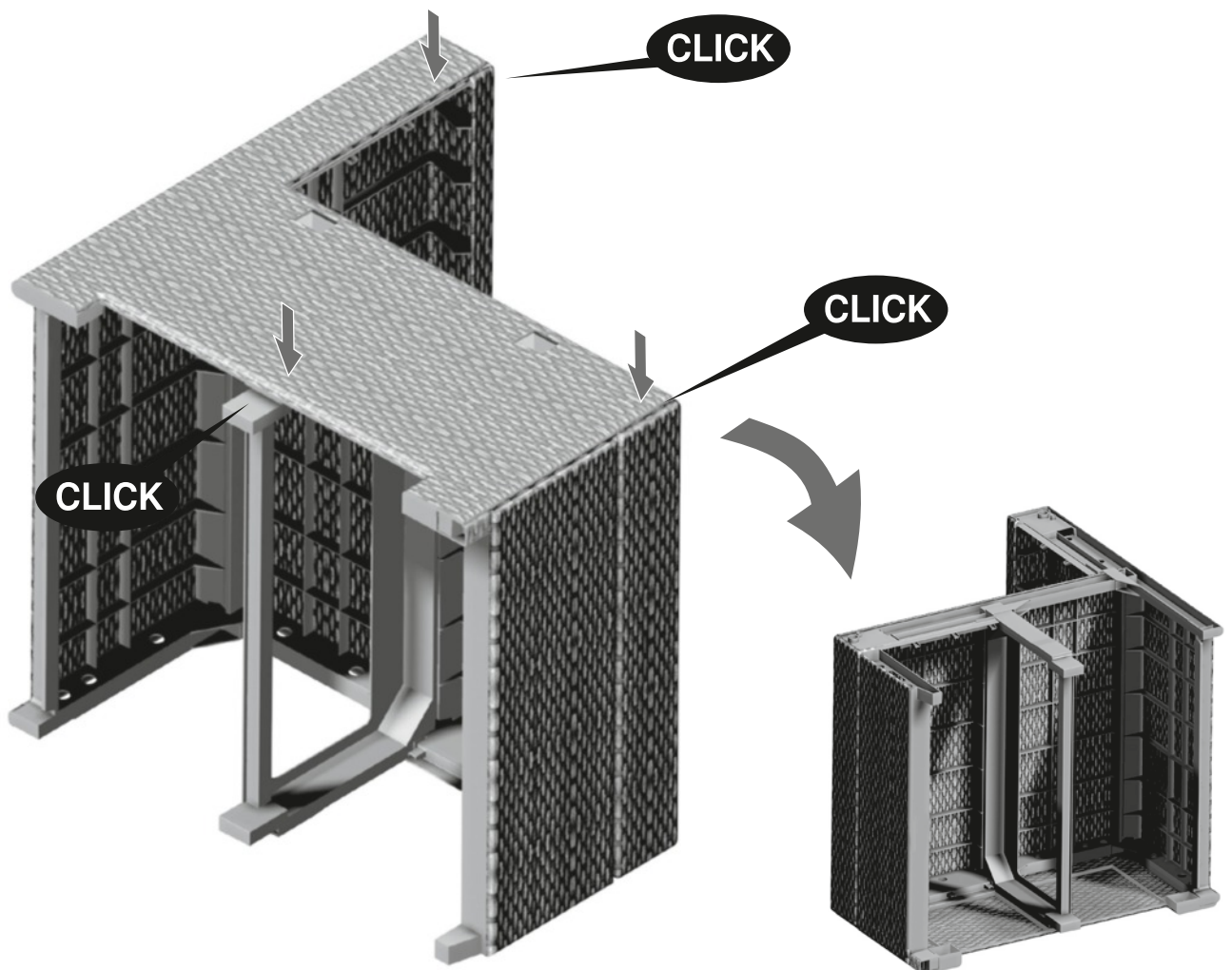
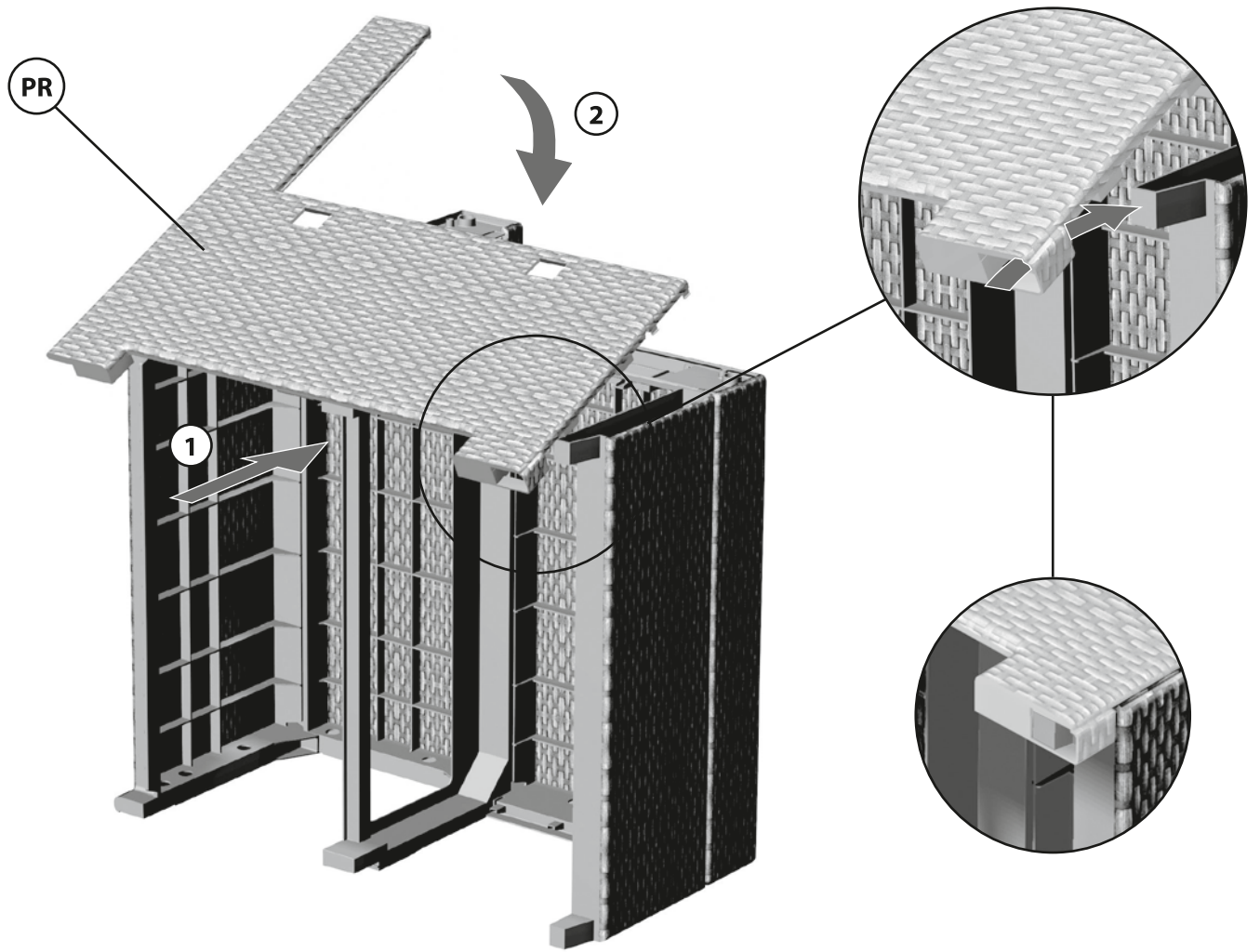

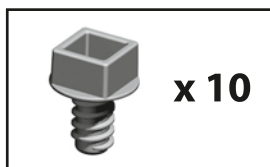
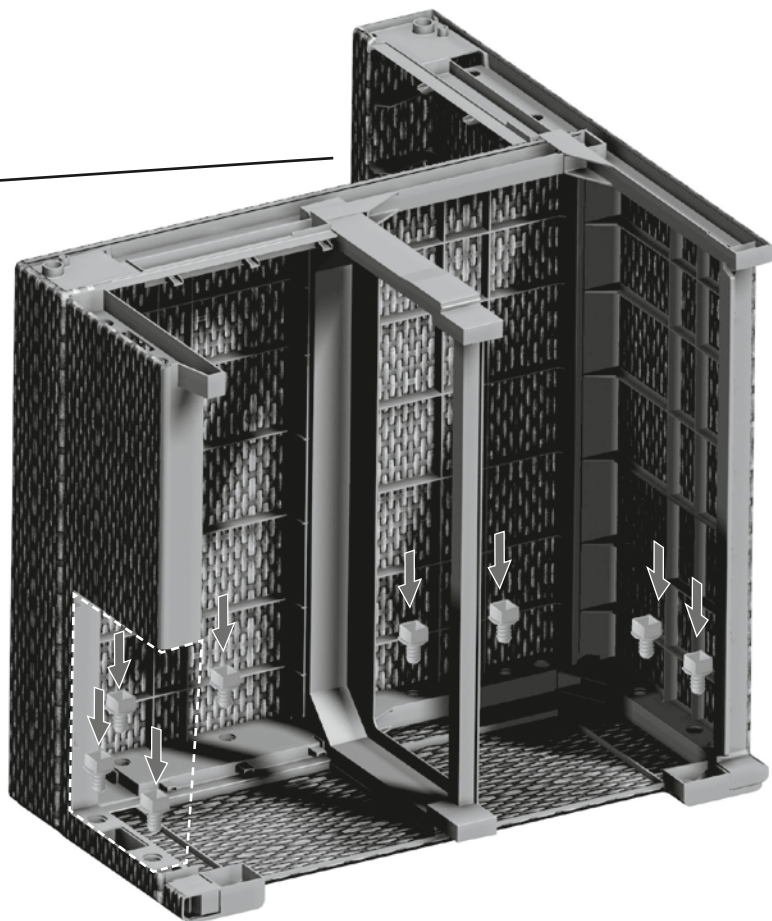
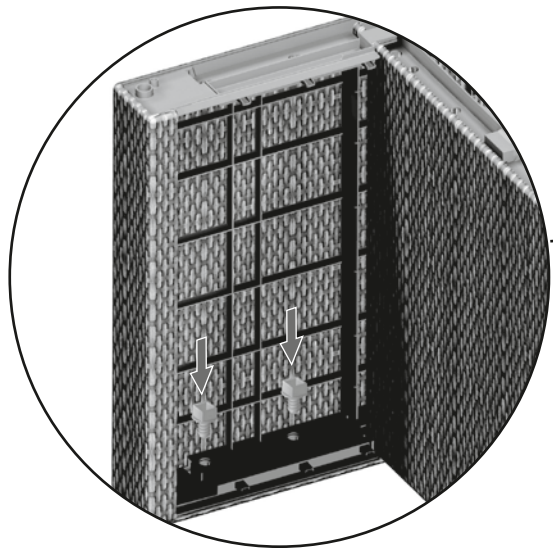

7

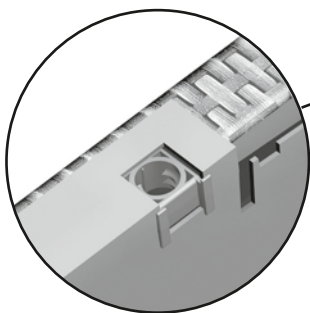
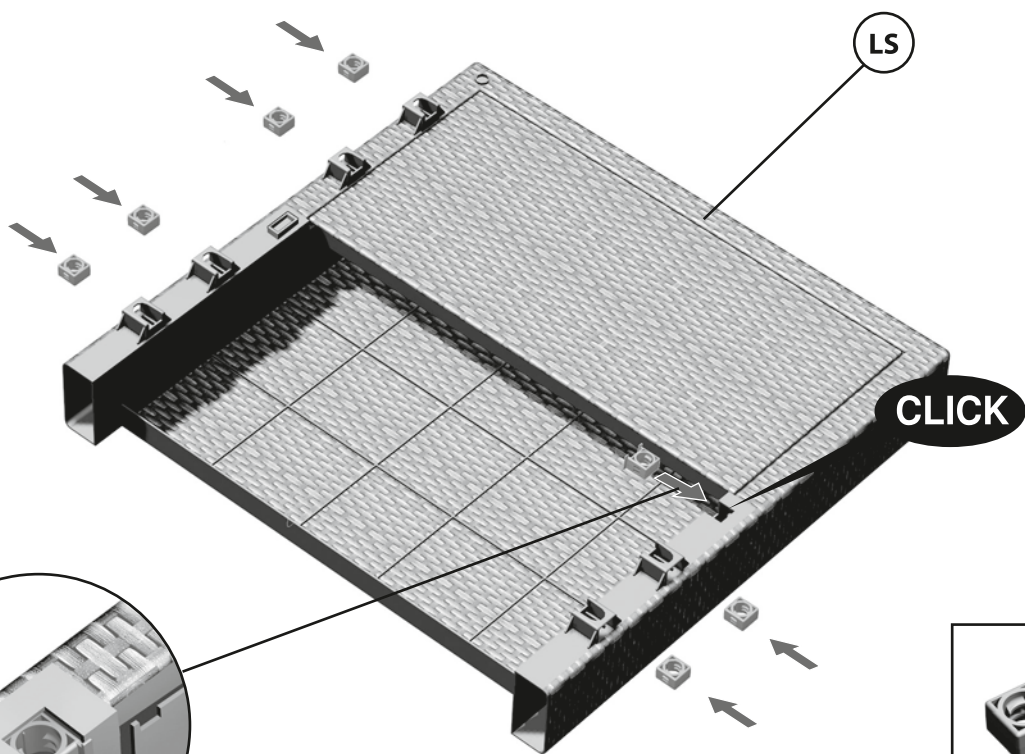

8

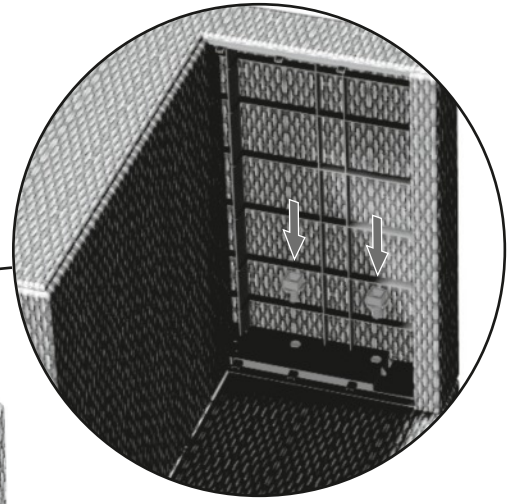
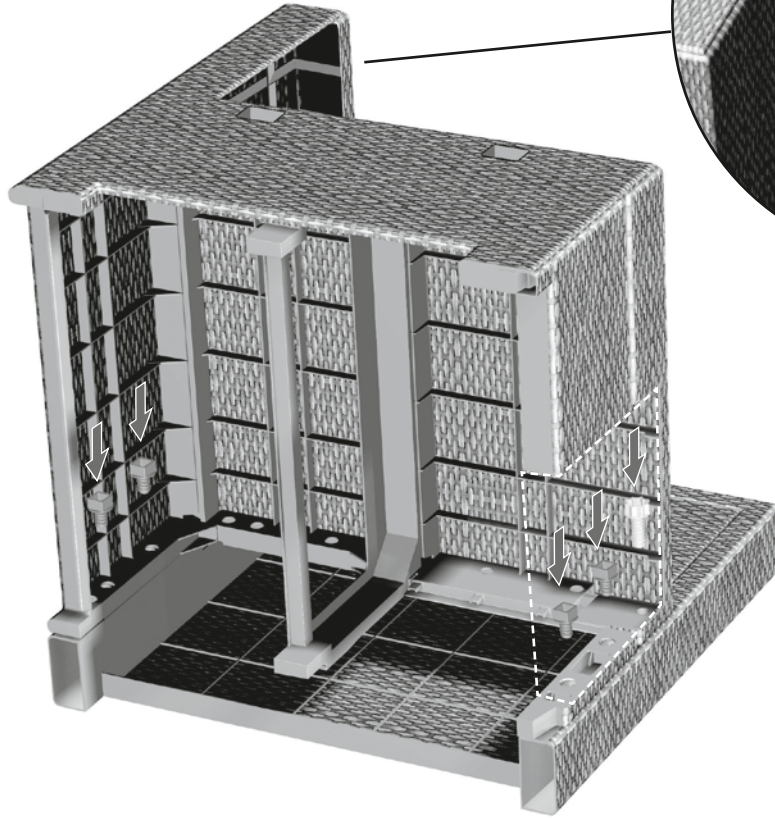
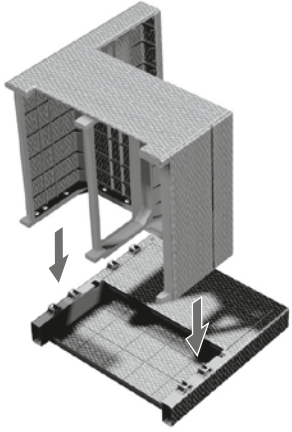

x 1



x 6

9

SP

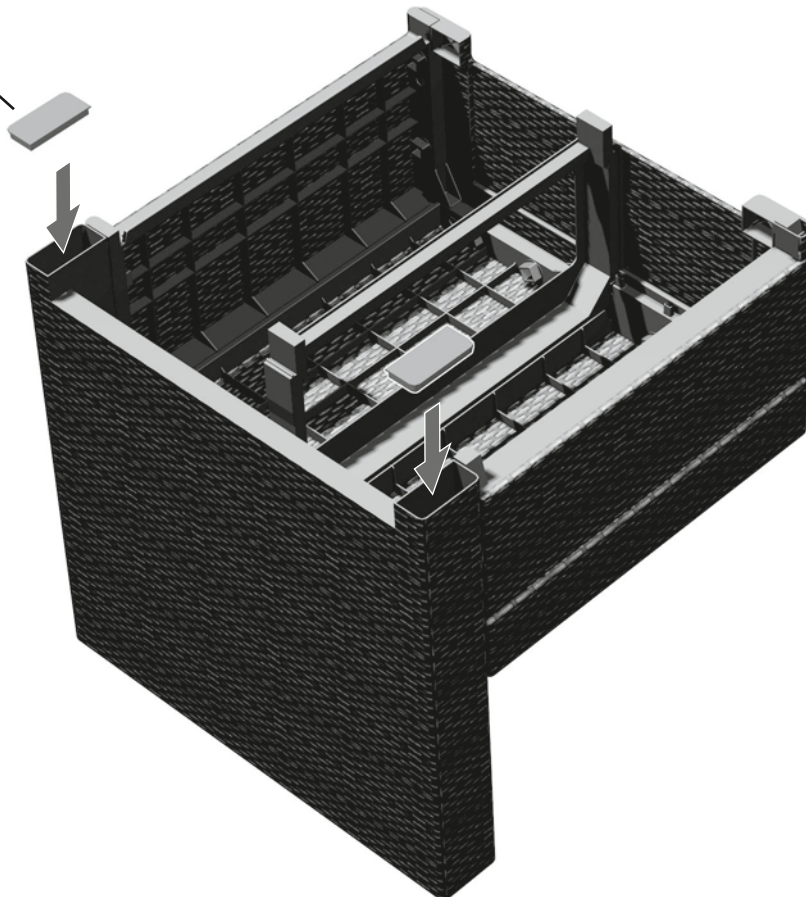

x 2

10

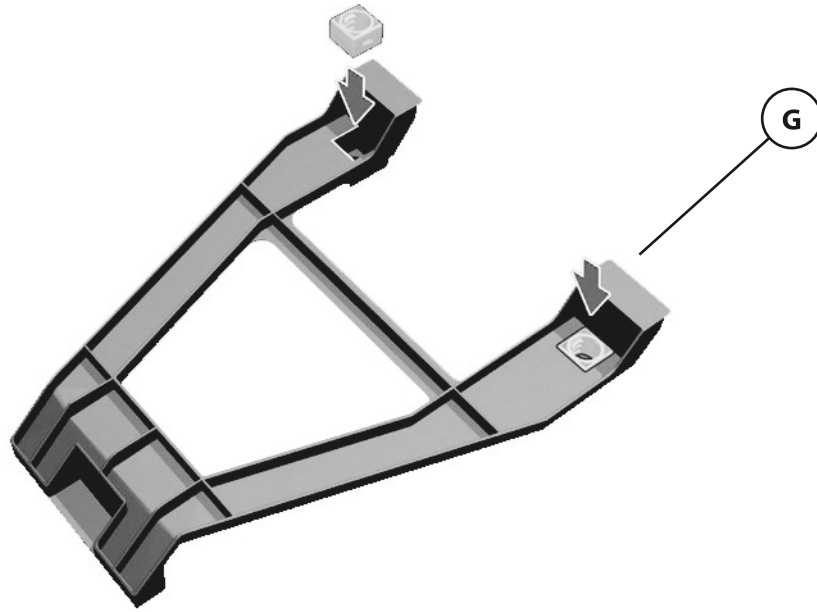
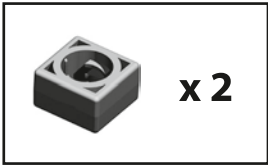

11

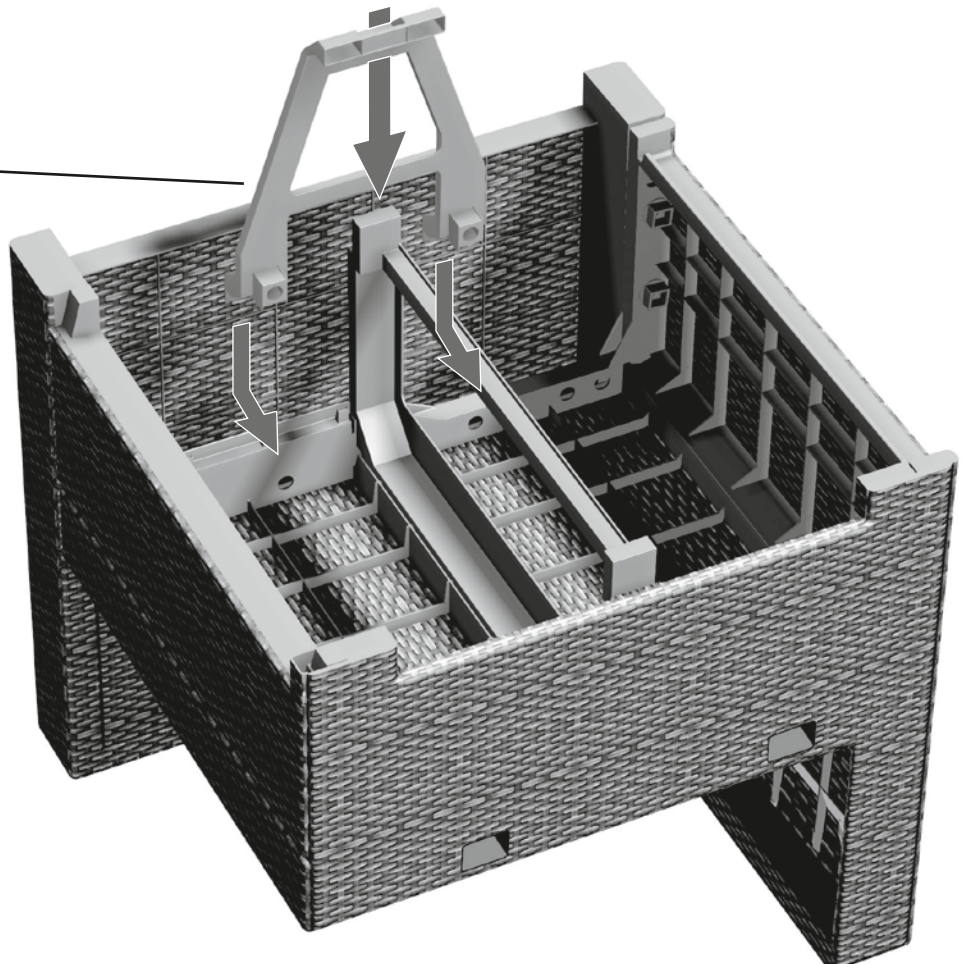

12

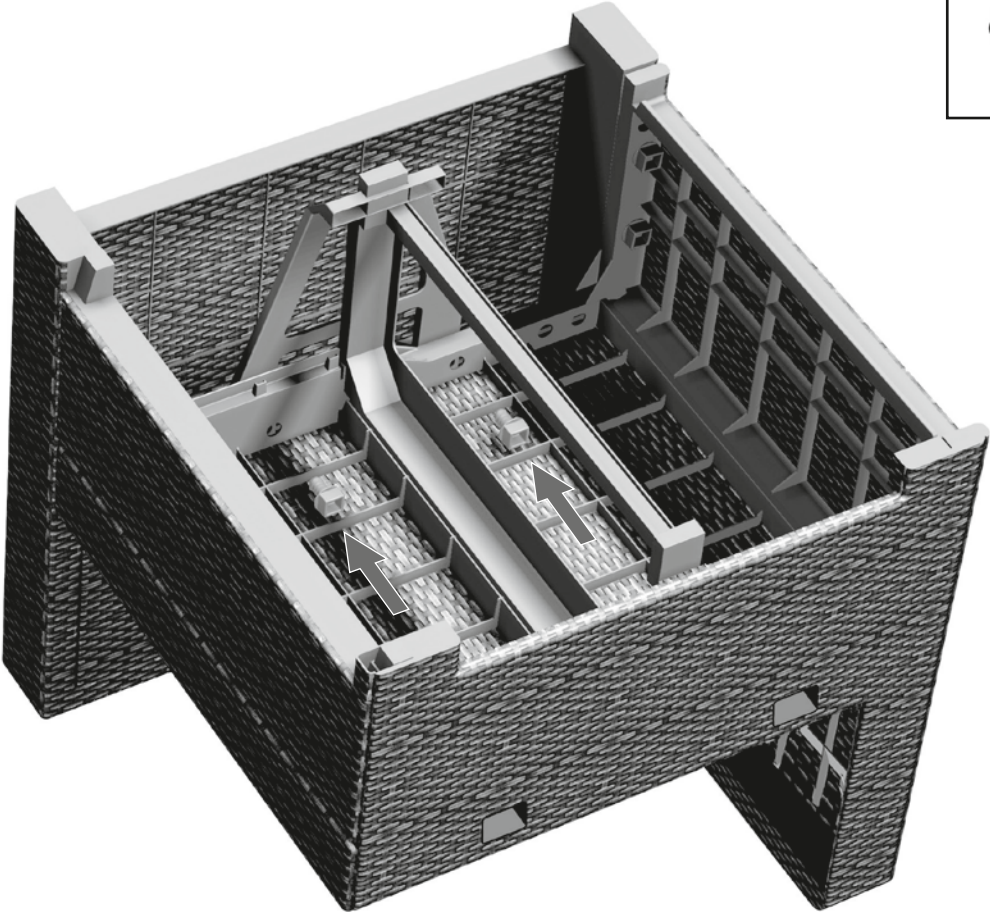
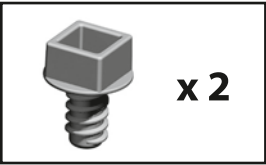

13

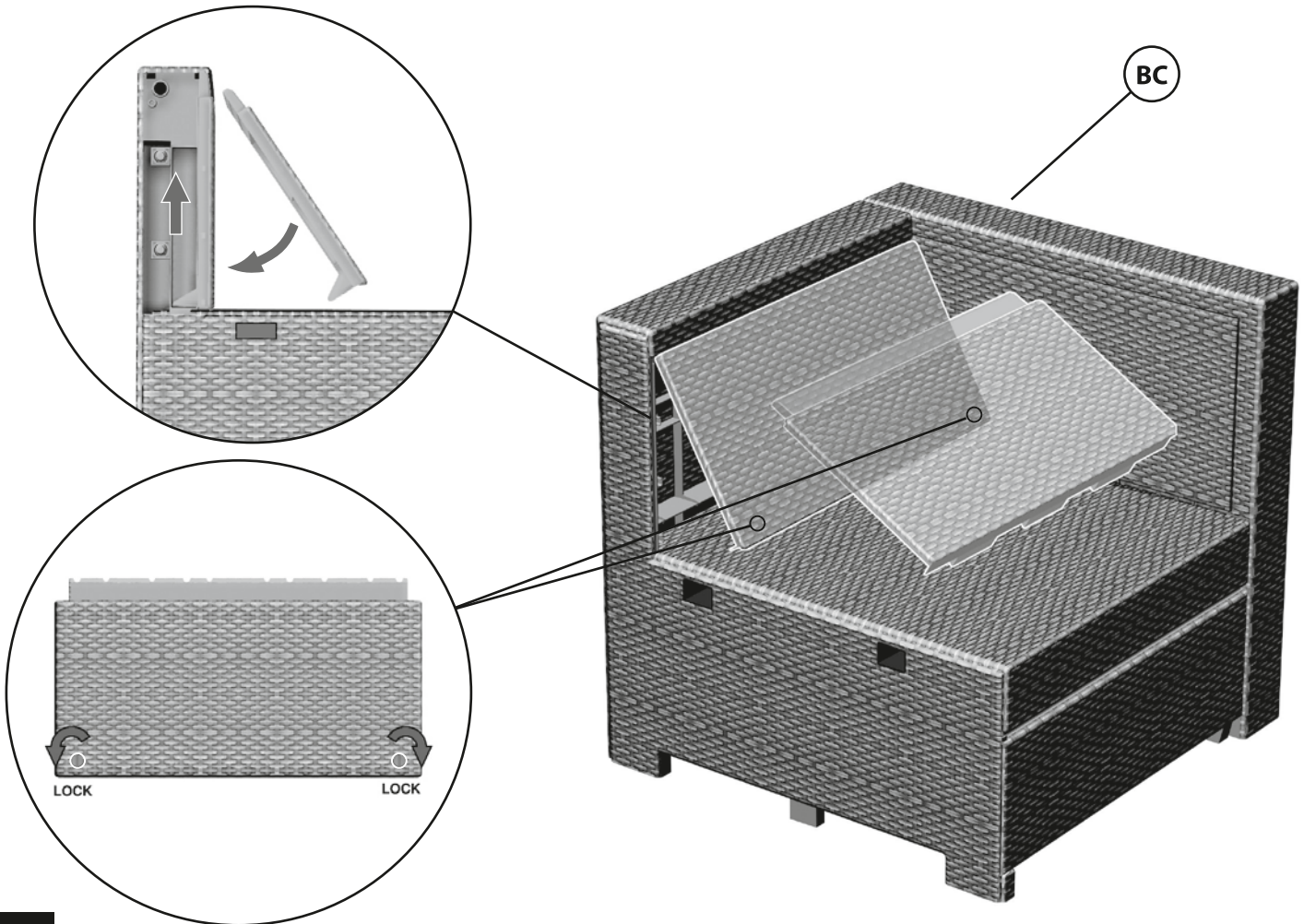

14

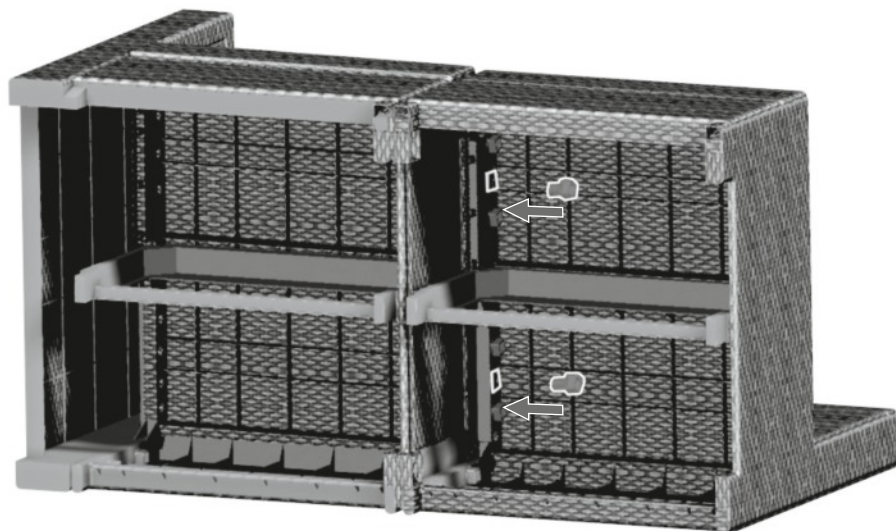
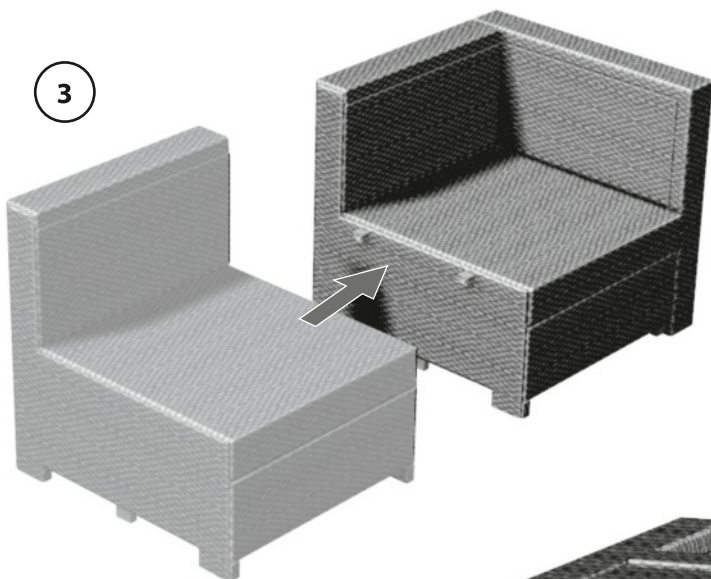
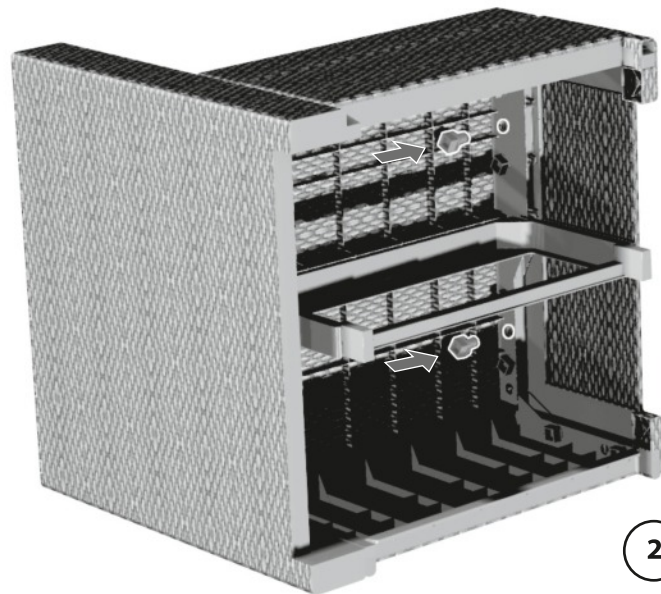
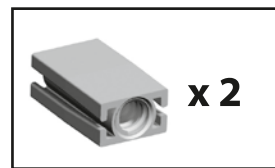
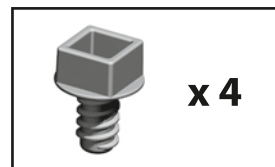
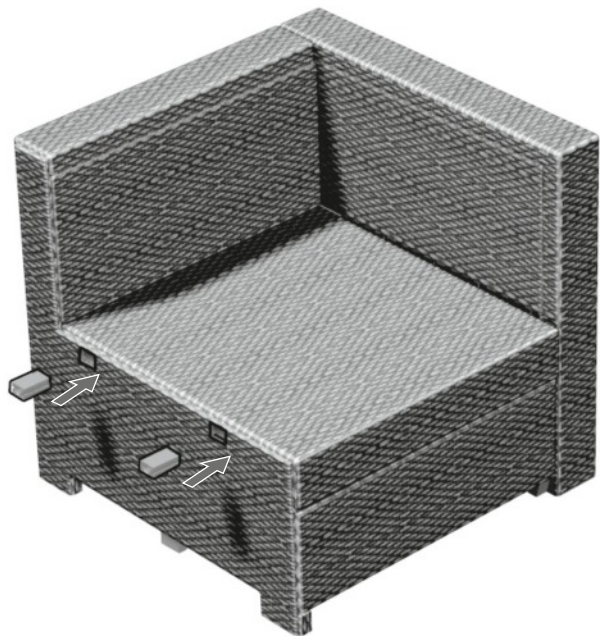

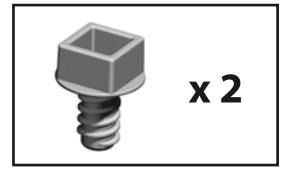
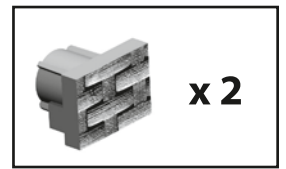
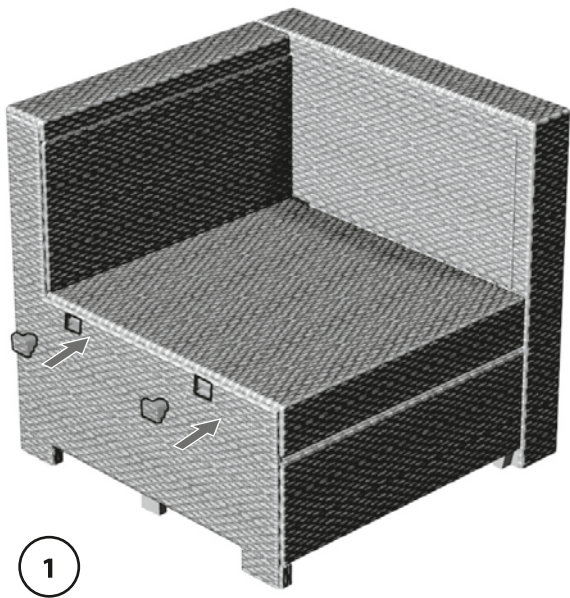

2

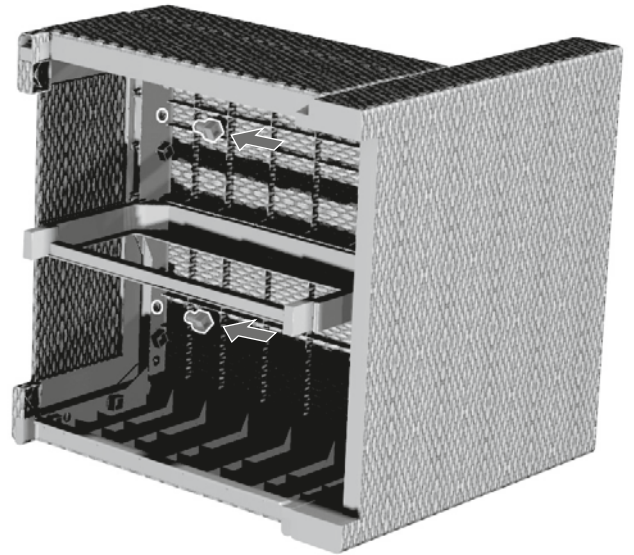

15B

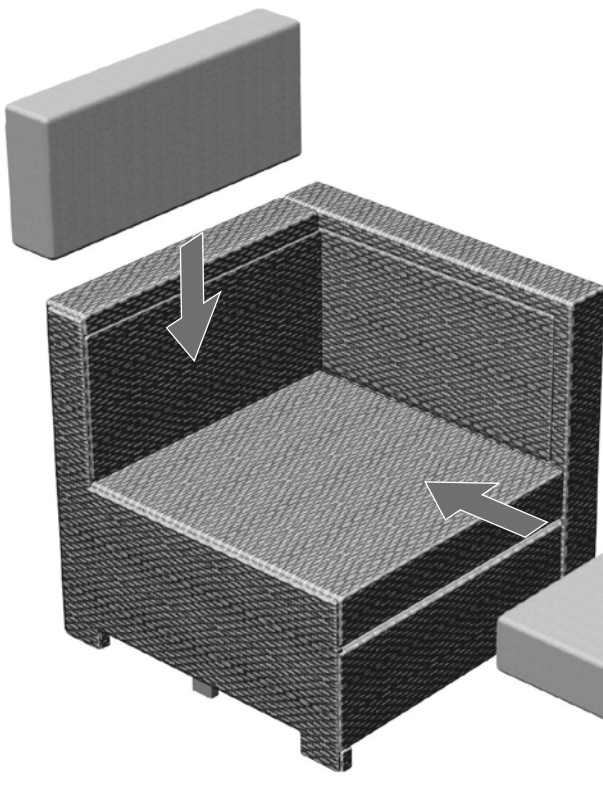

16

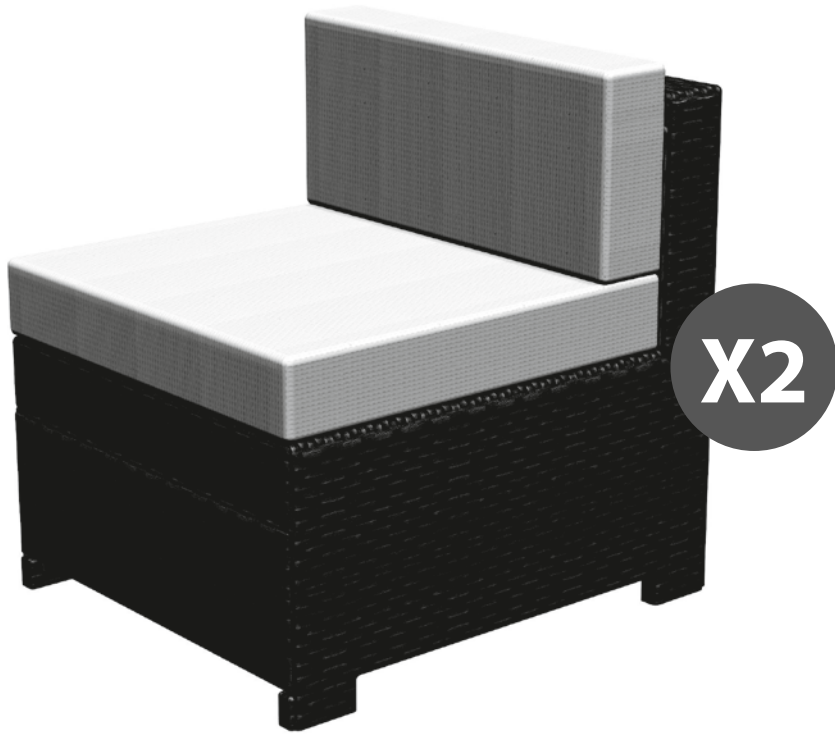

X2

Zawartość | Contents | Tartalom | Obsah | Obsah | Vsebina | Conținut | Sadržaj | Sadržaj | Turinys | Saturs | Sisu | Комплектація | Содержание

<p>F x1</p>	<p>BC x1</p>	<p>x4</p>
<p>PL x1</p>	<p>PR x1</p>	<p>x1</p>
<p>Back x1</p>	<p>Seat x1</p>	<p>x24</p>
<p>L x1</p>	<p>x1</p>	<p>x1</p>
		<p>x20</p>
		<p>x4</p>
		<p>x2</p>

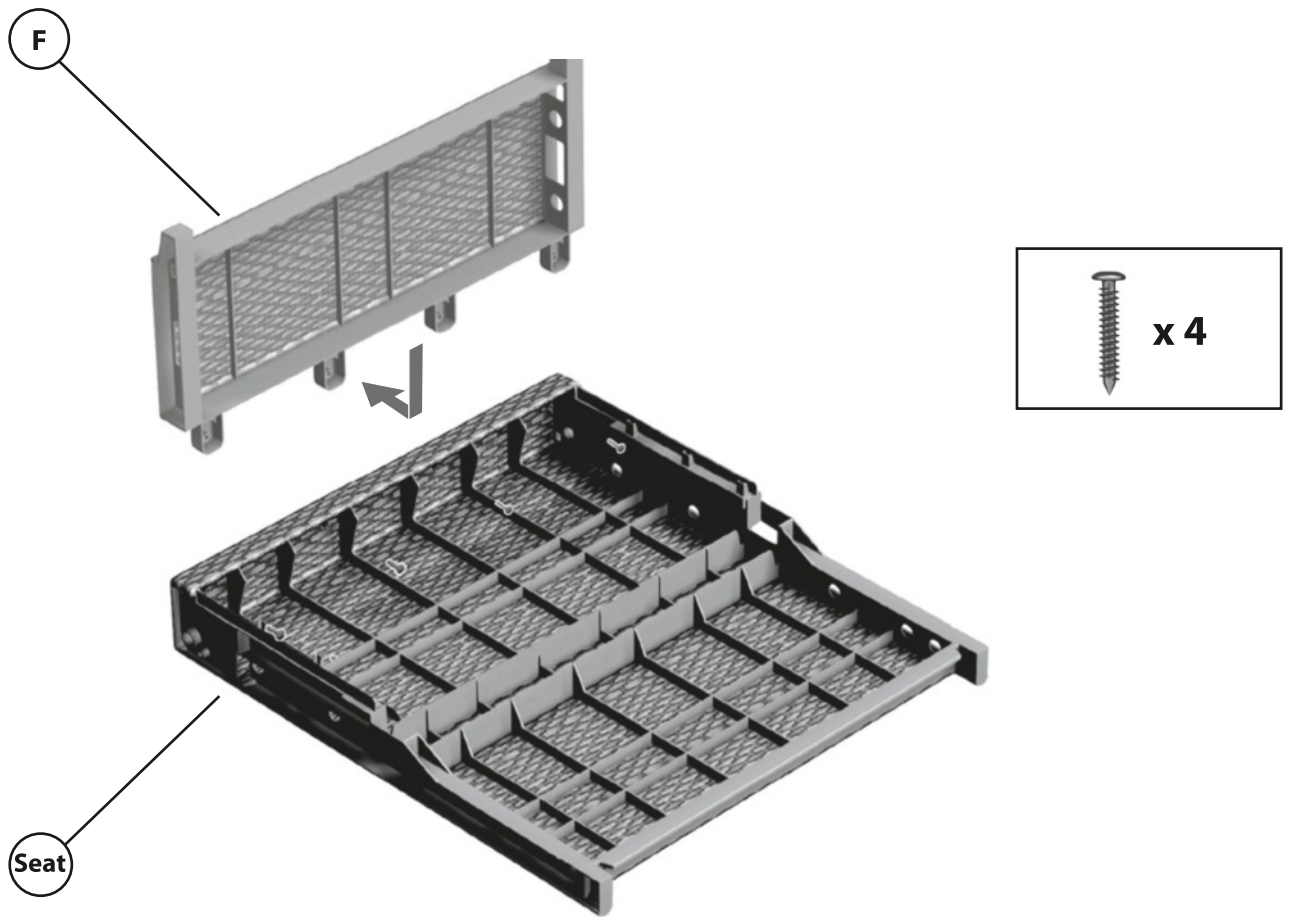

1

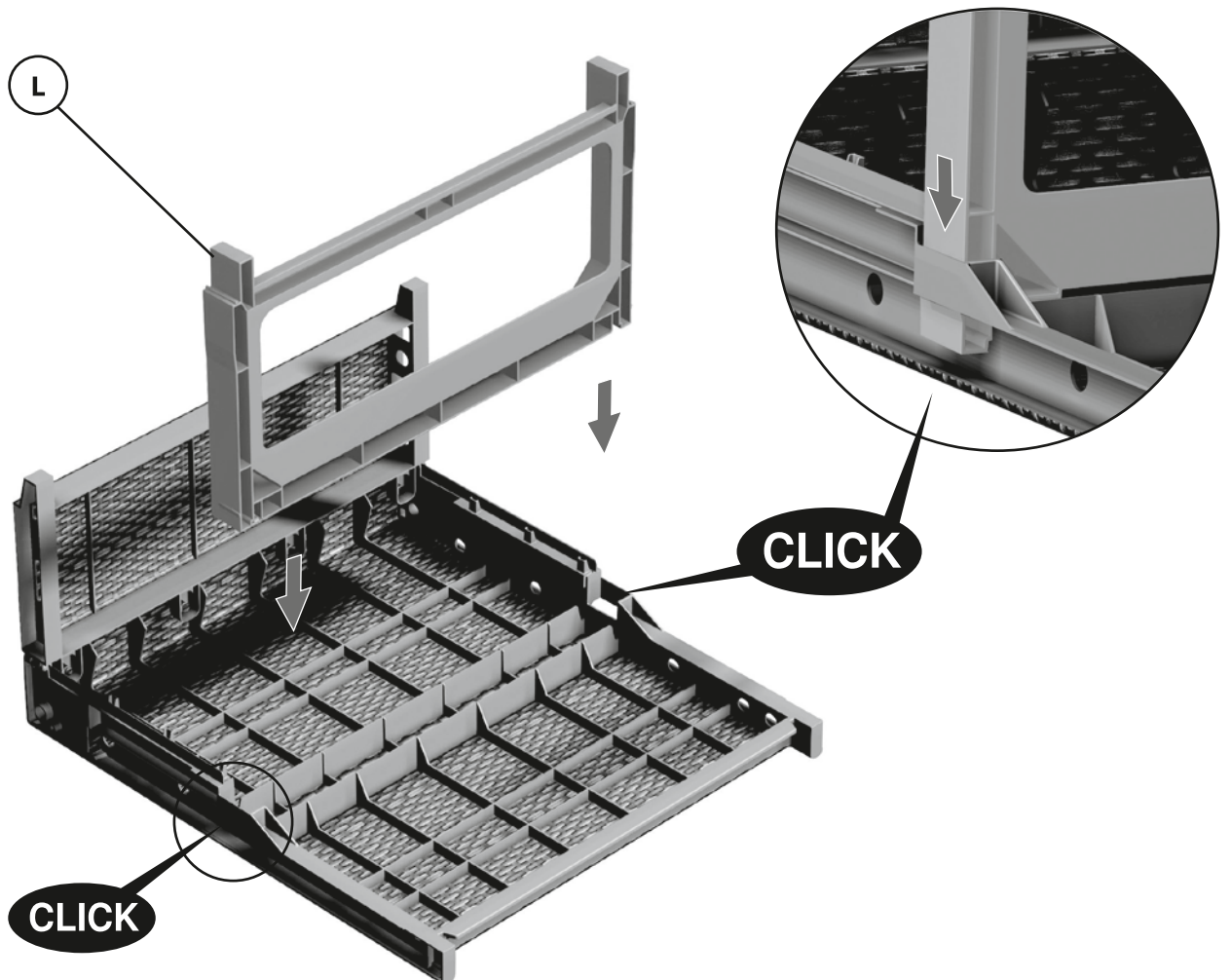

2

Back

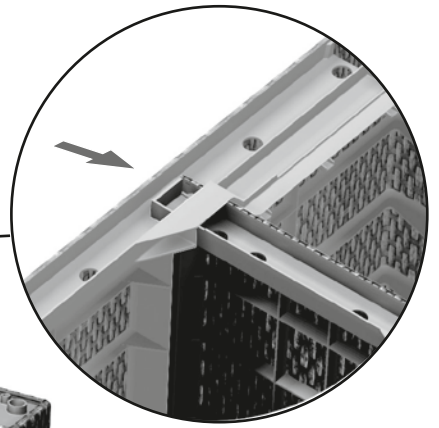
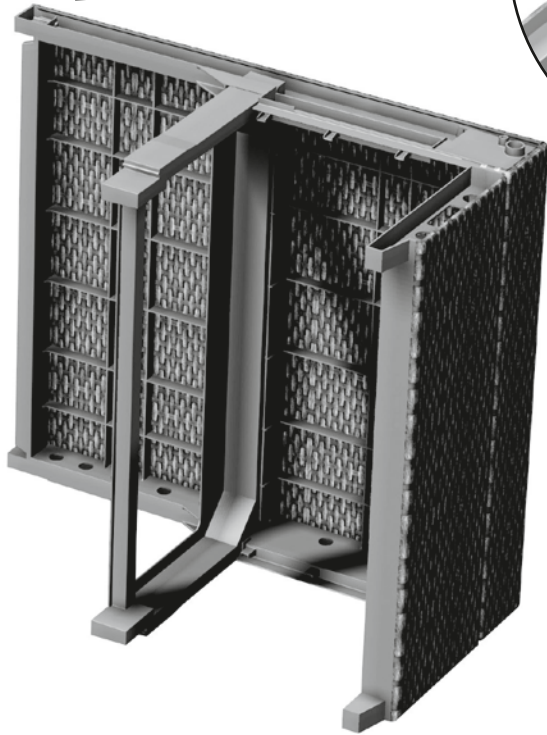
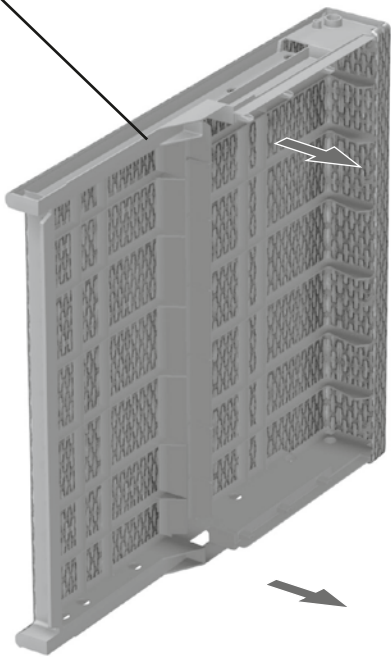

3

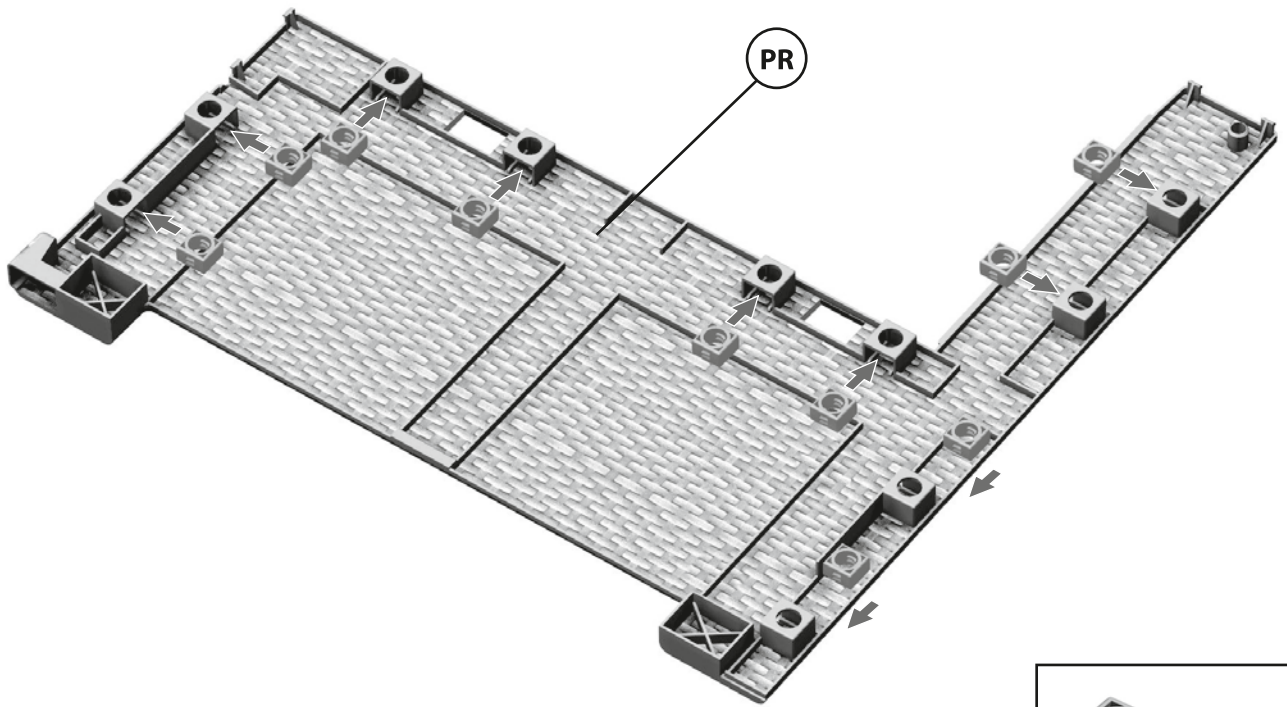

PR

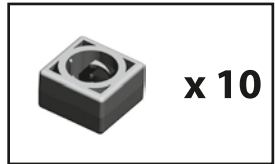

4

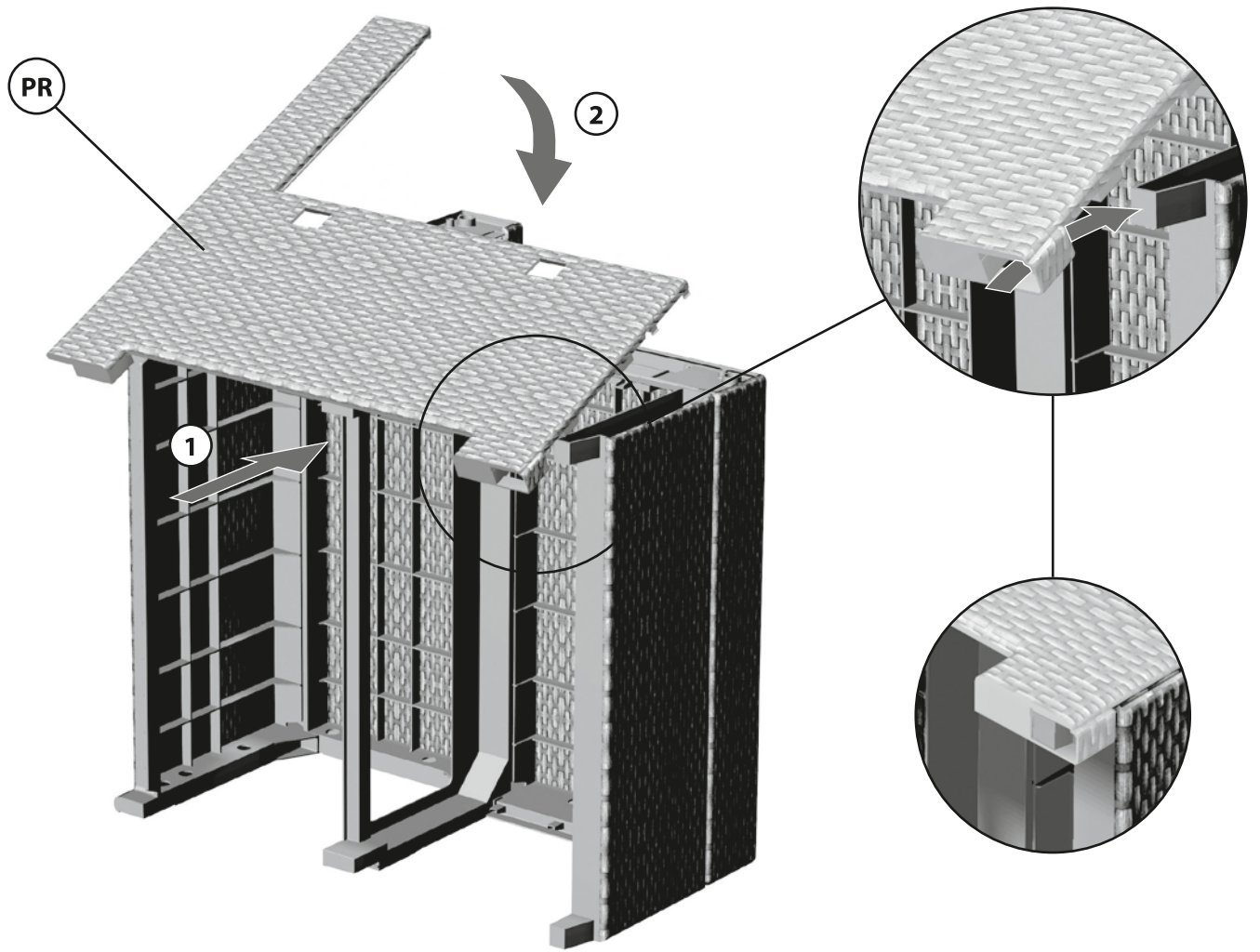

5

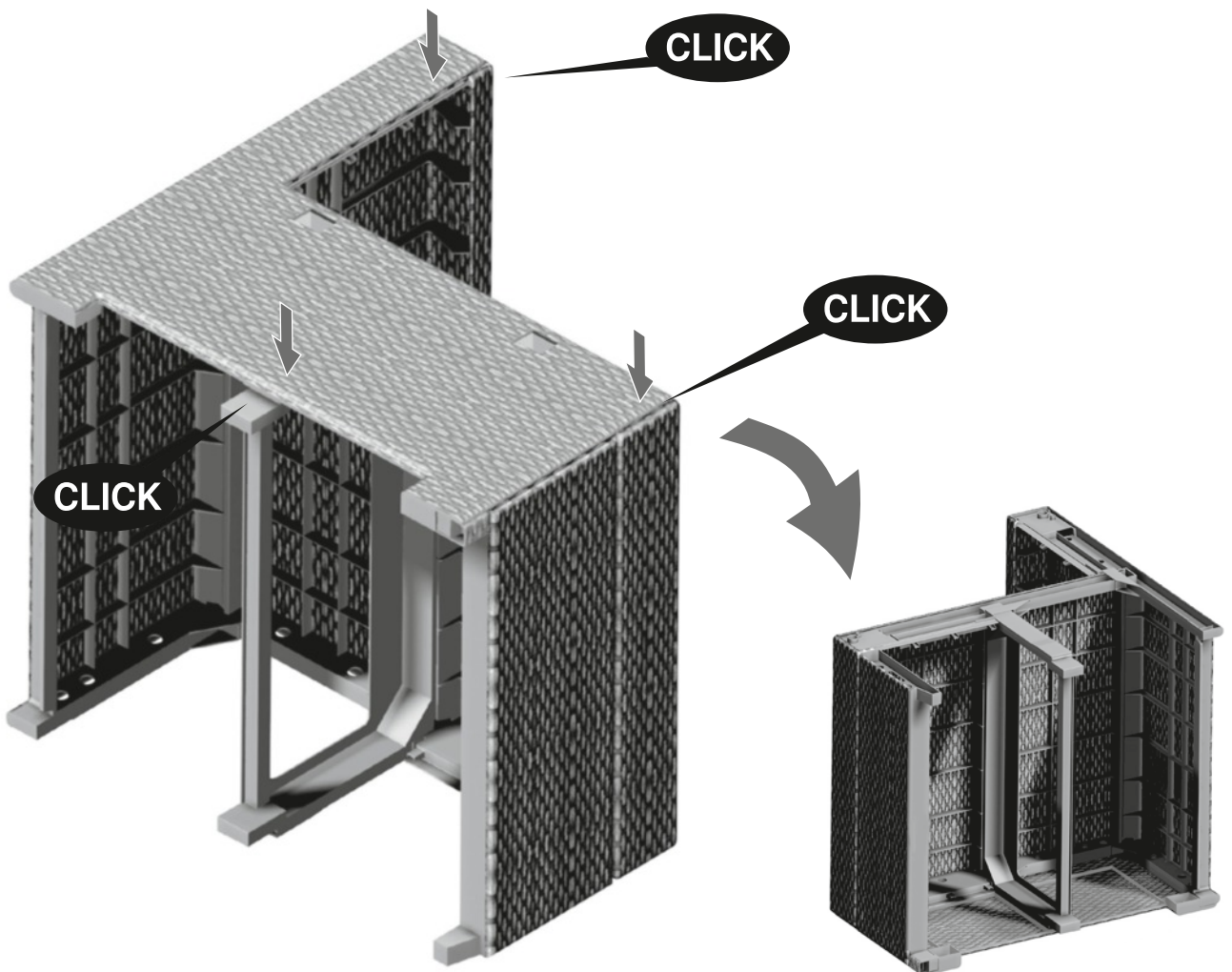

6

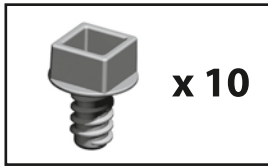
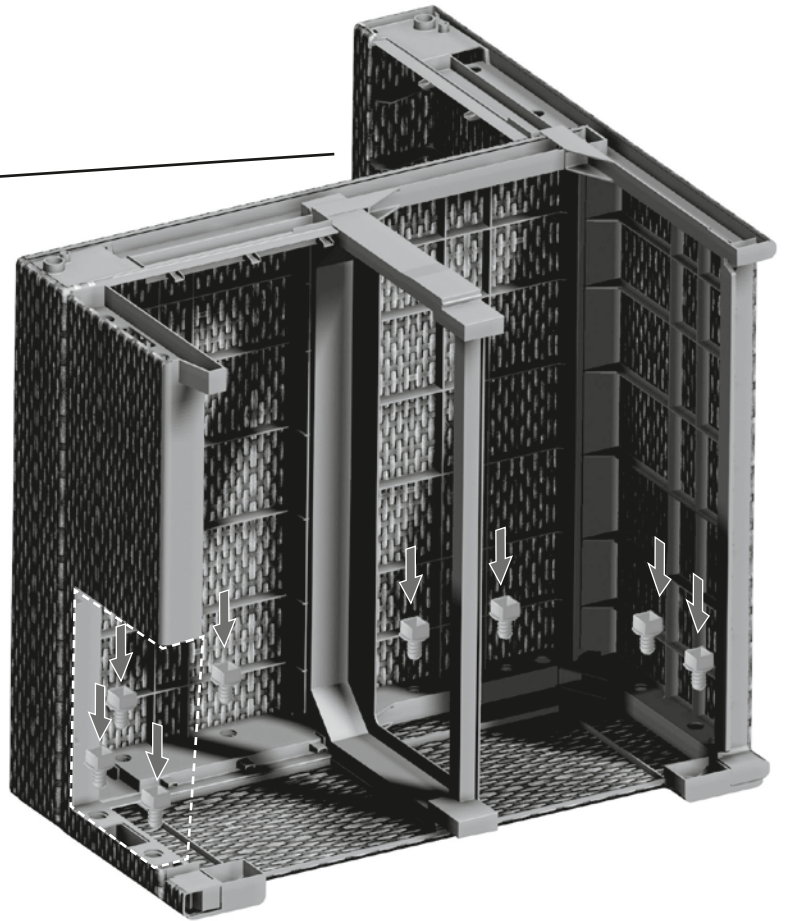
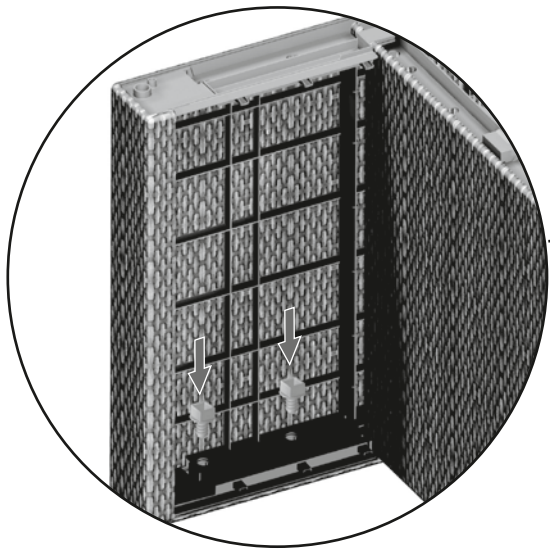

x 10

7

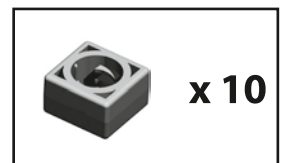
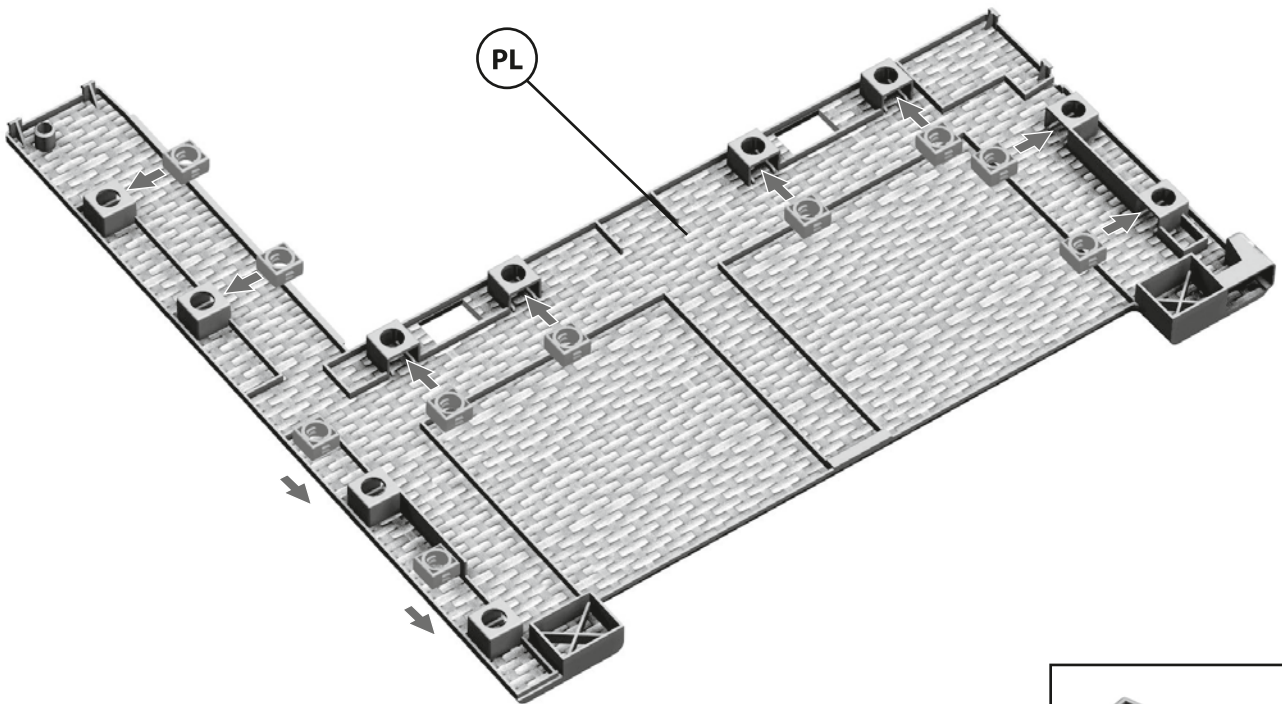

x 10

8

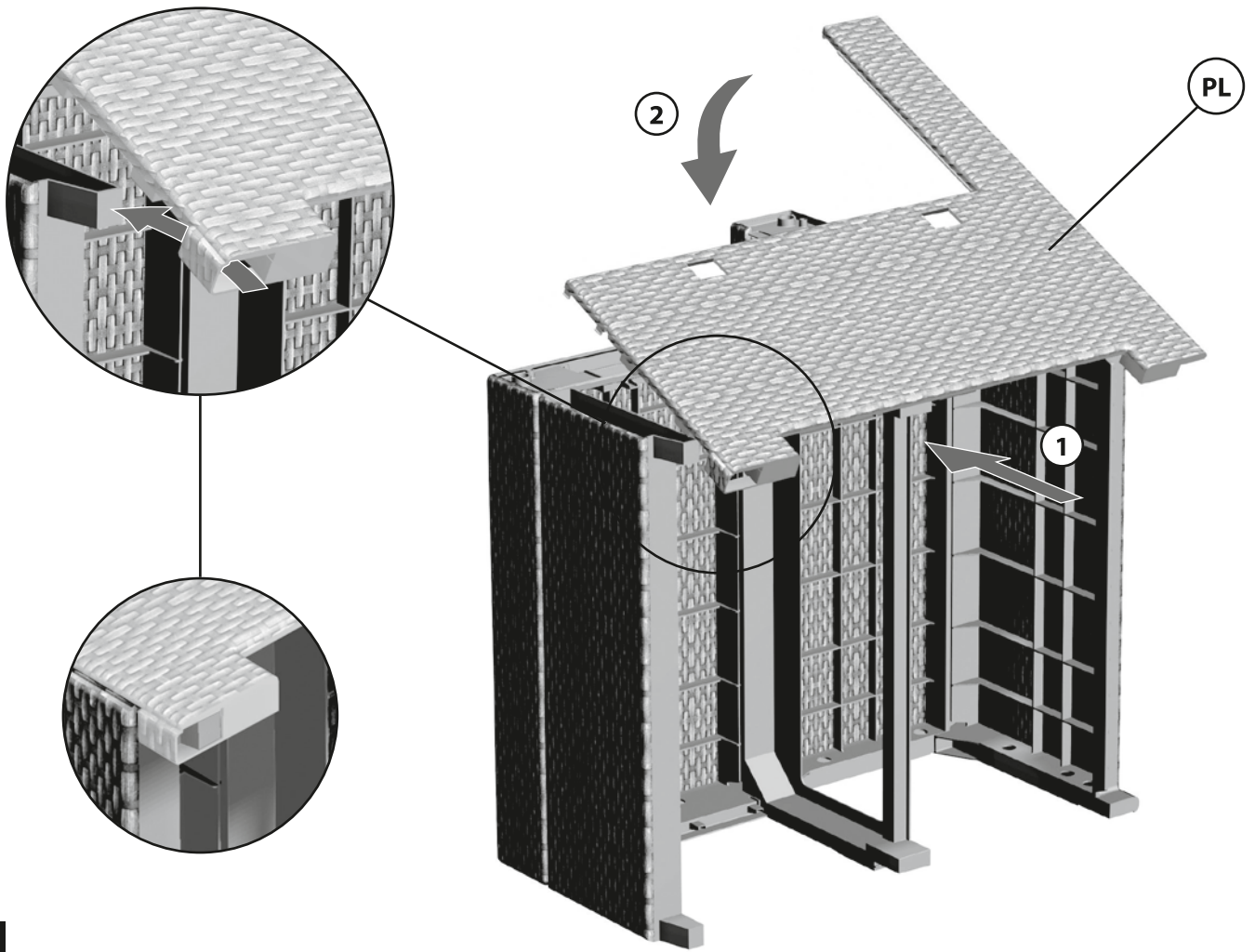

9

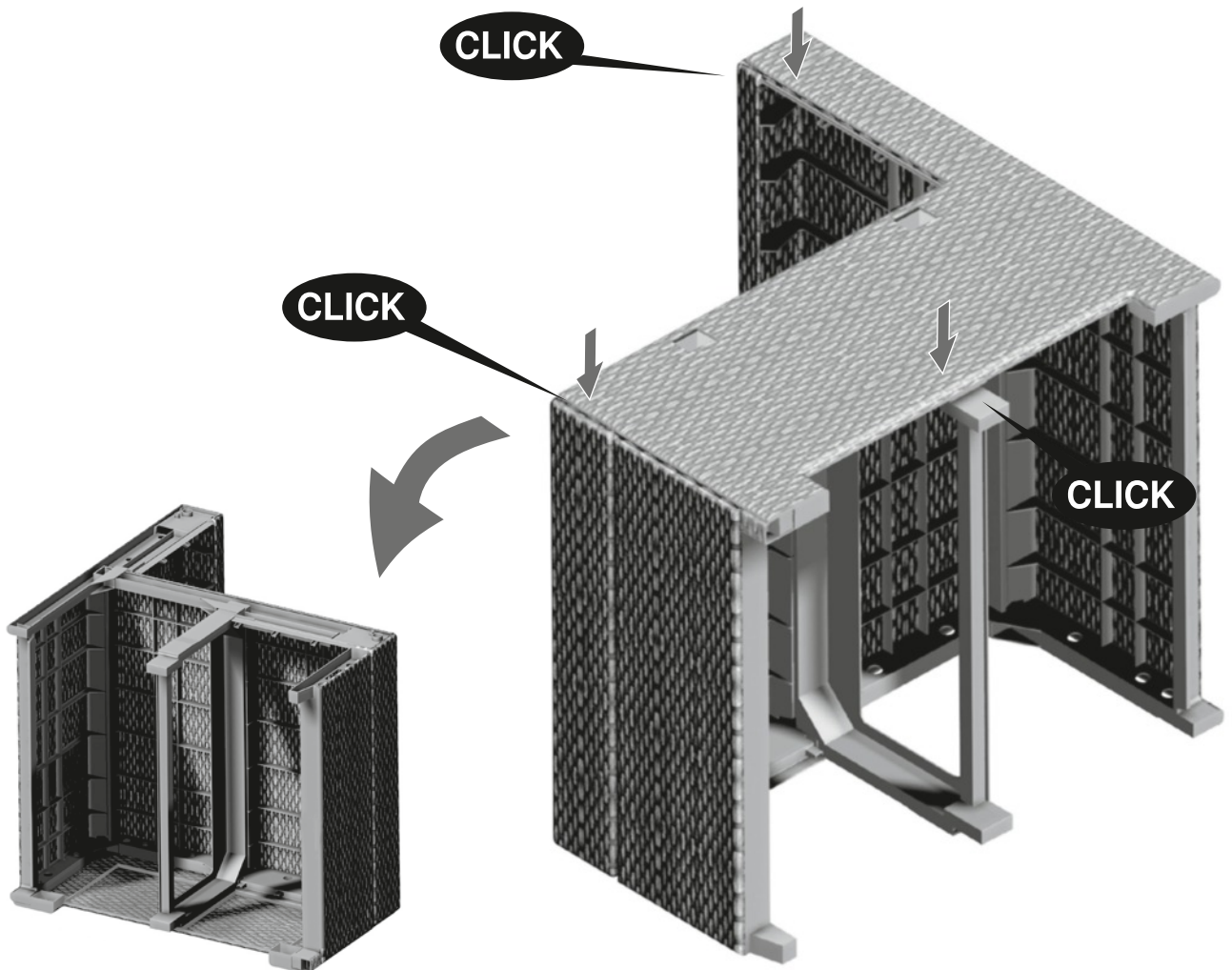

10

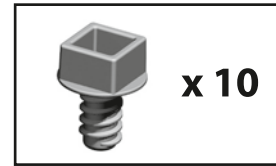
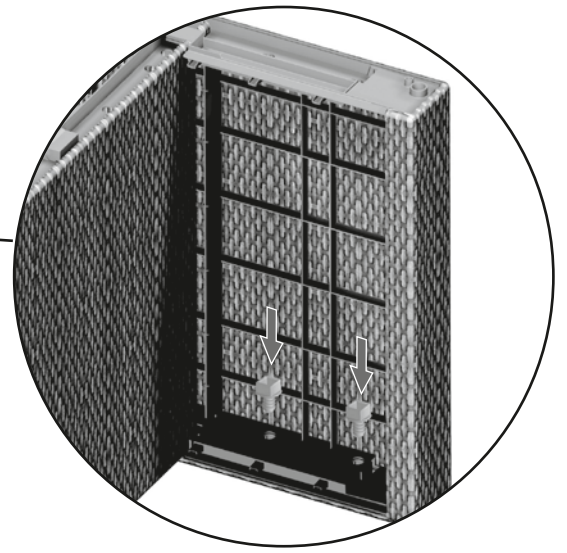
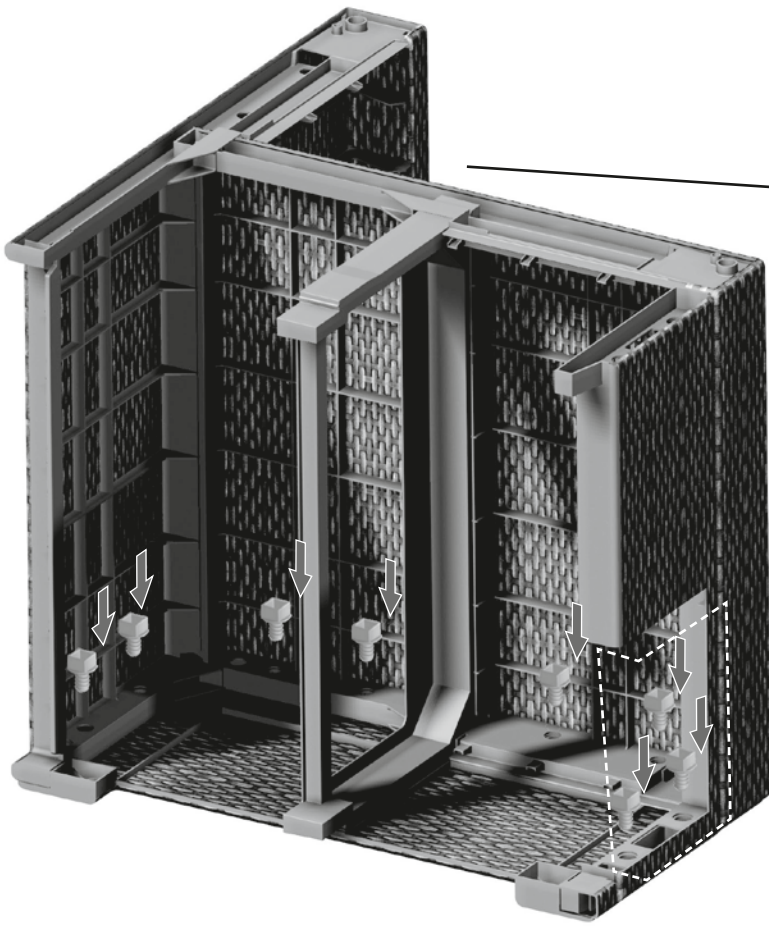

11

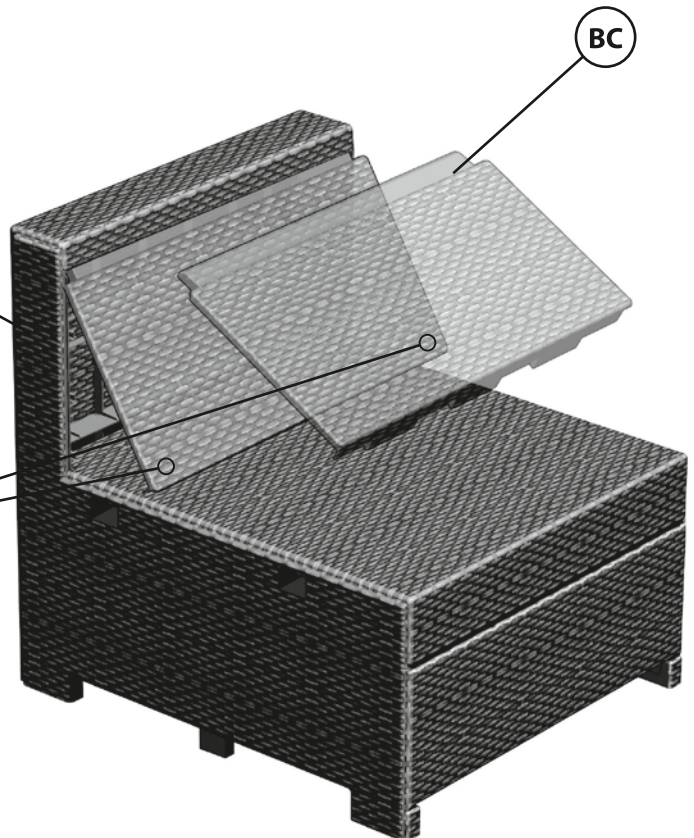
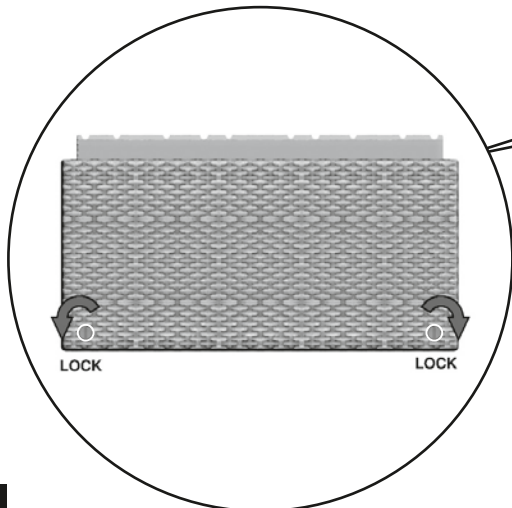
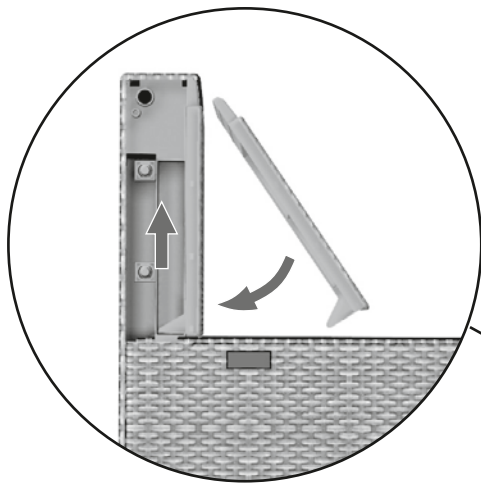

12

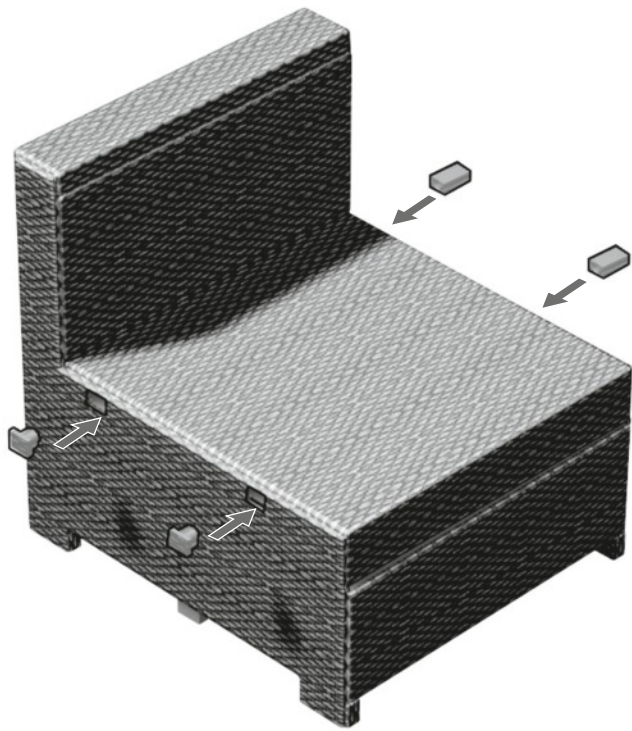

1

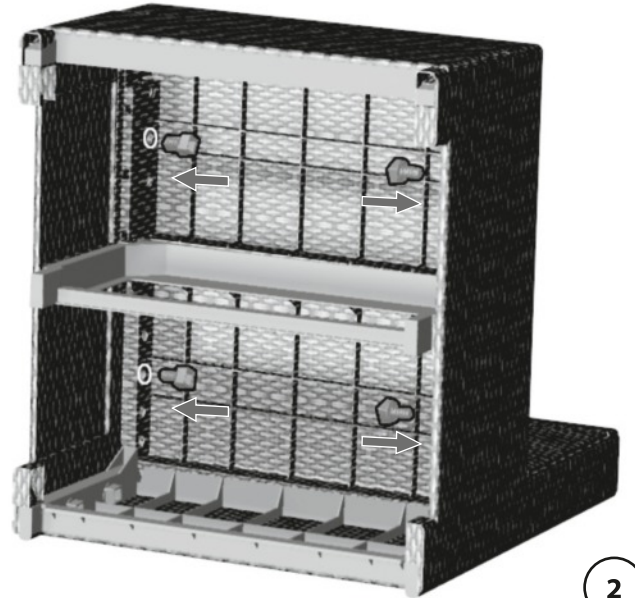
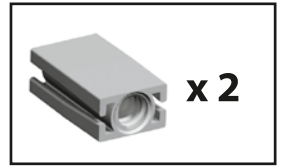
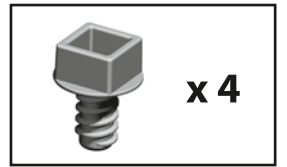
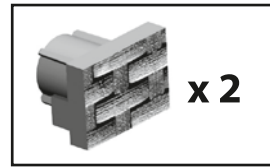

2

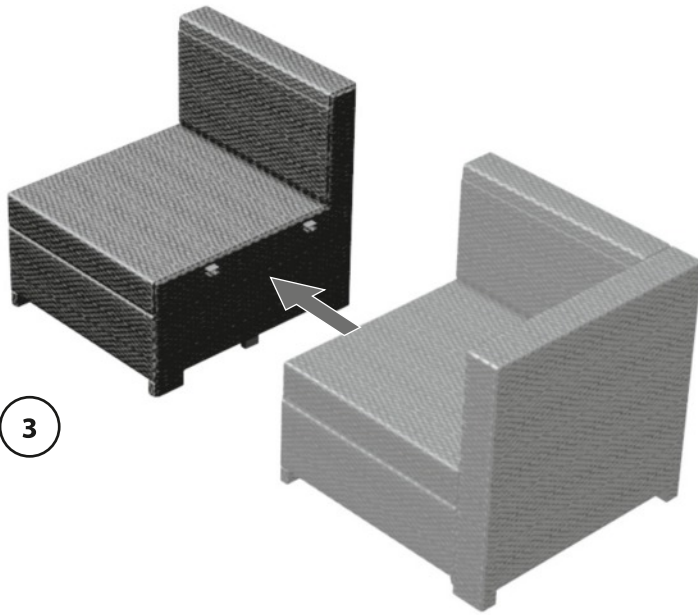

3

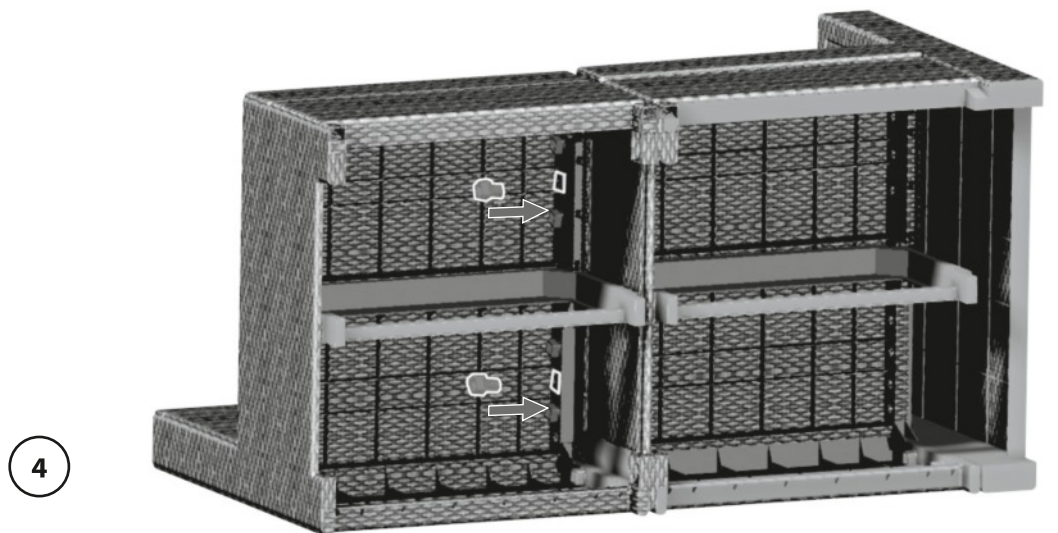

4

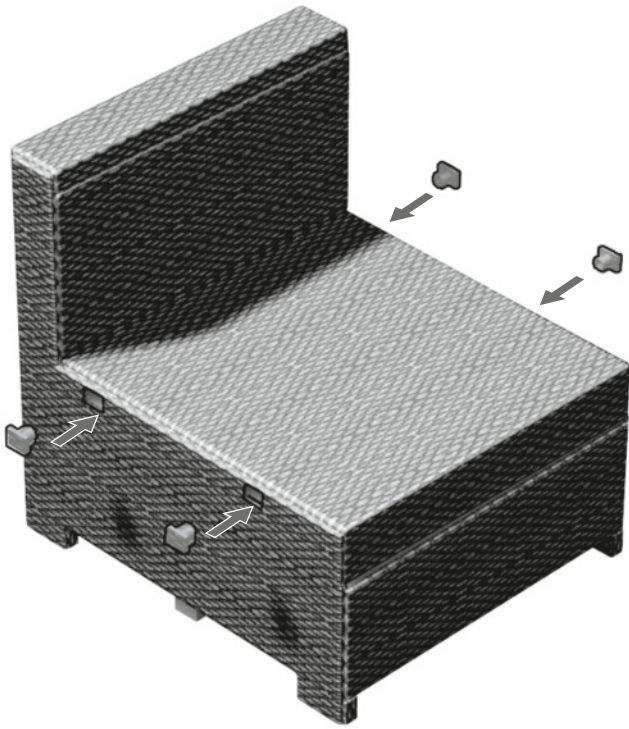

1

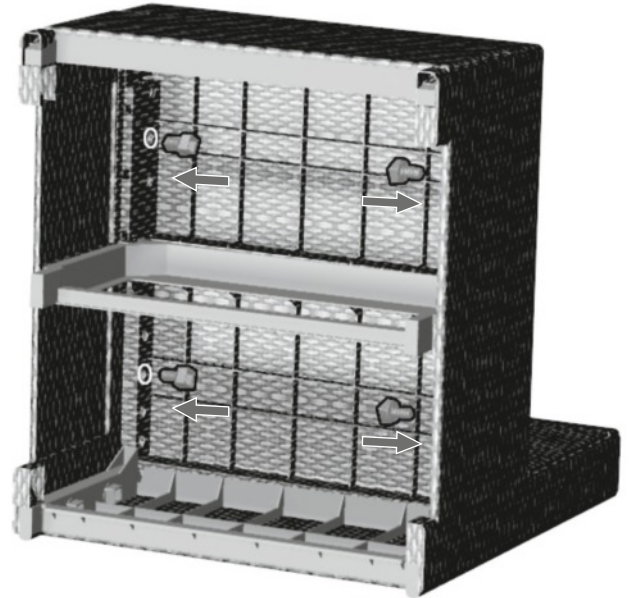
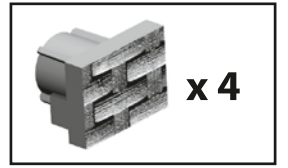
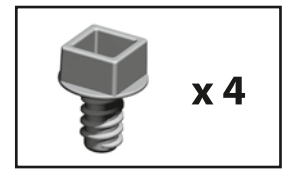

2

13B

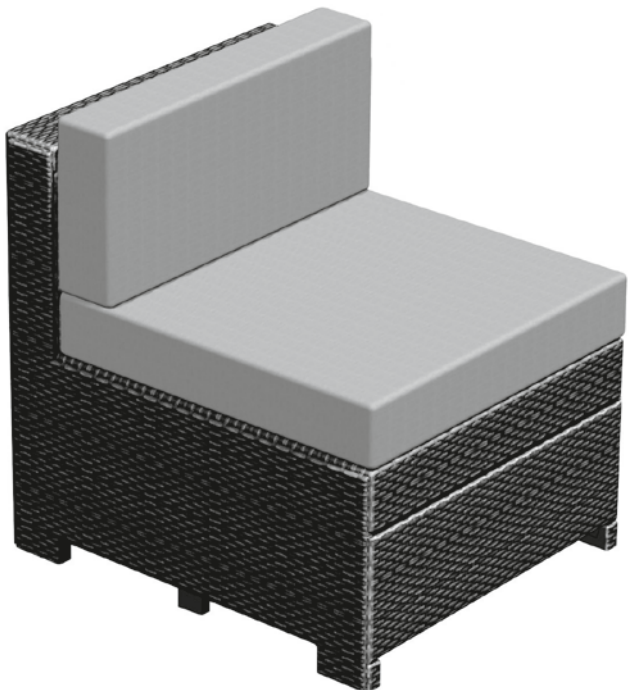
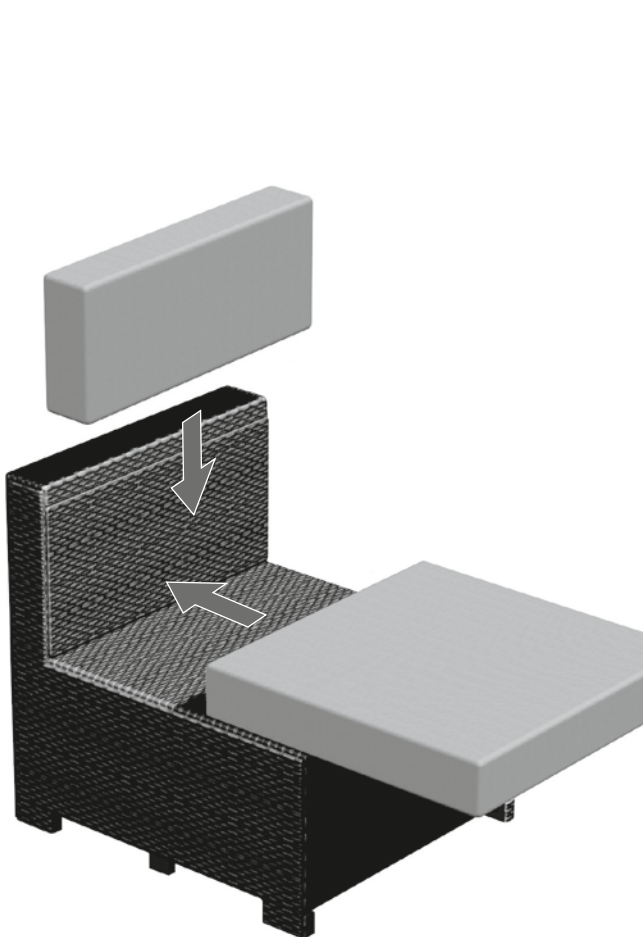

14

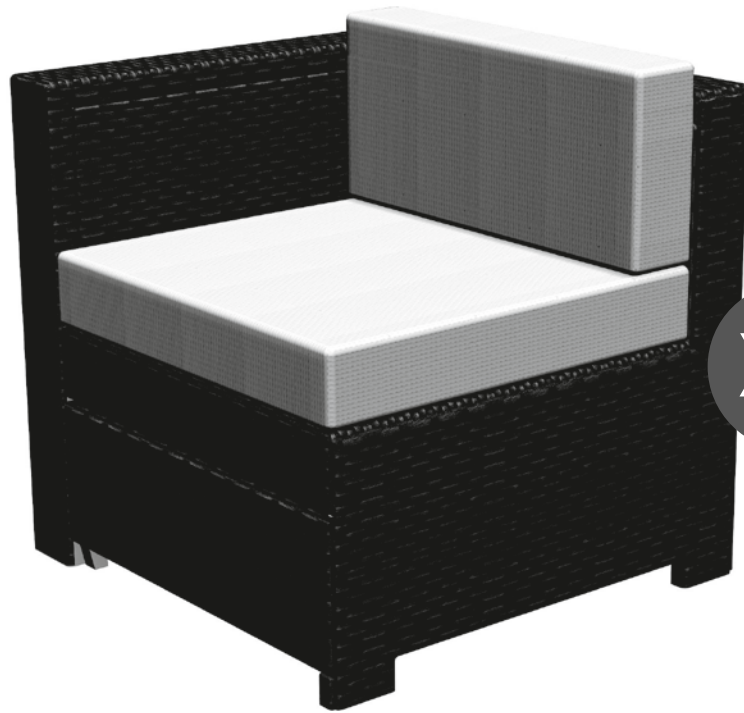

X2

<p>F x1</p>	<p>RS x1</p>	<p>SP x2</p>	<p>G x1</p>
<p>PL x1</p>	<p>BC x1</p>	<p>x4</p>	<p>x1</p>
<p>Back x1</p>	<p>Seat x1</p>	<p>x1</p>	<p>x20</p>
<p>L x1</p>	<p>x1</p>	<p>x1</p>	<p>x18</p>
		<p>x1</p>	<p>x1</p>
			<p>x2</p>

F

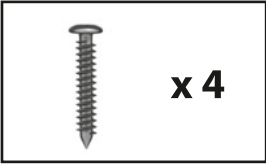
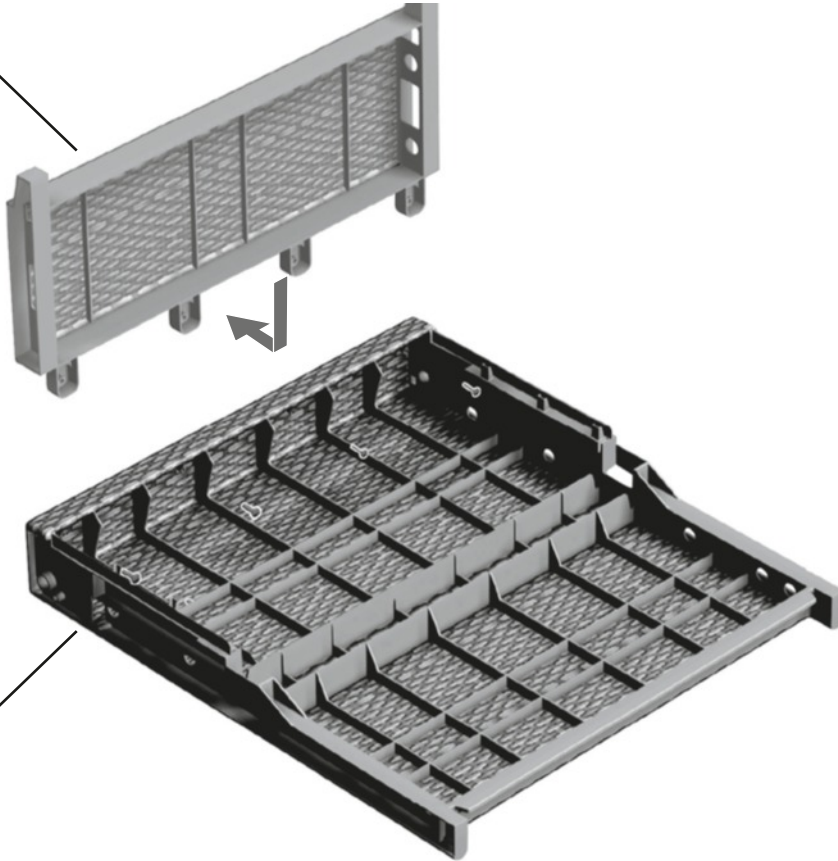

Seat

1

L

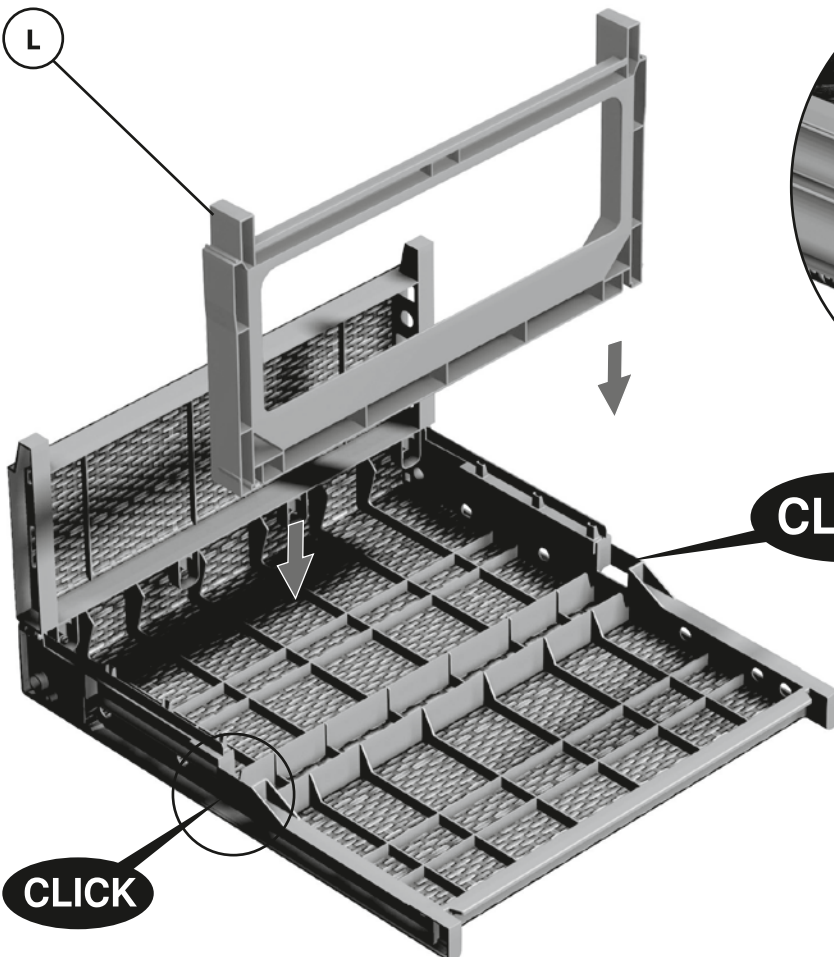

CLICK

CLICK

2

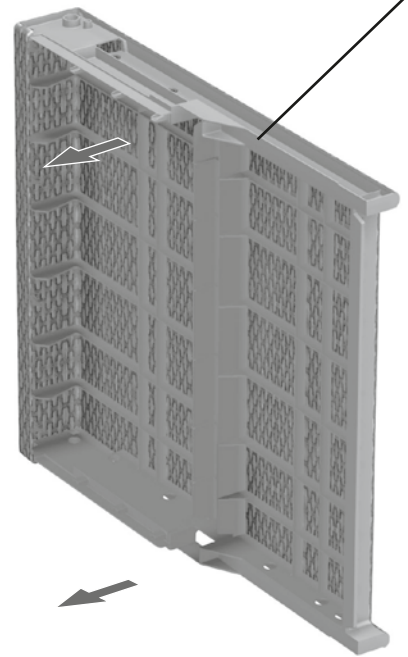
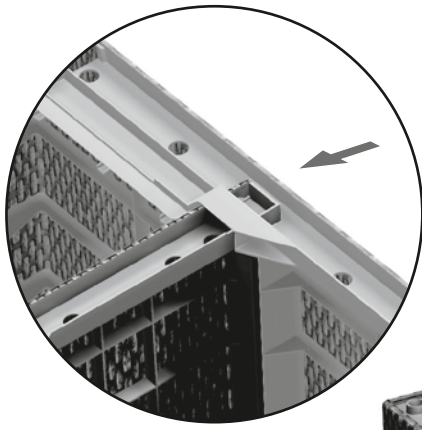

Back

3

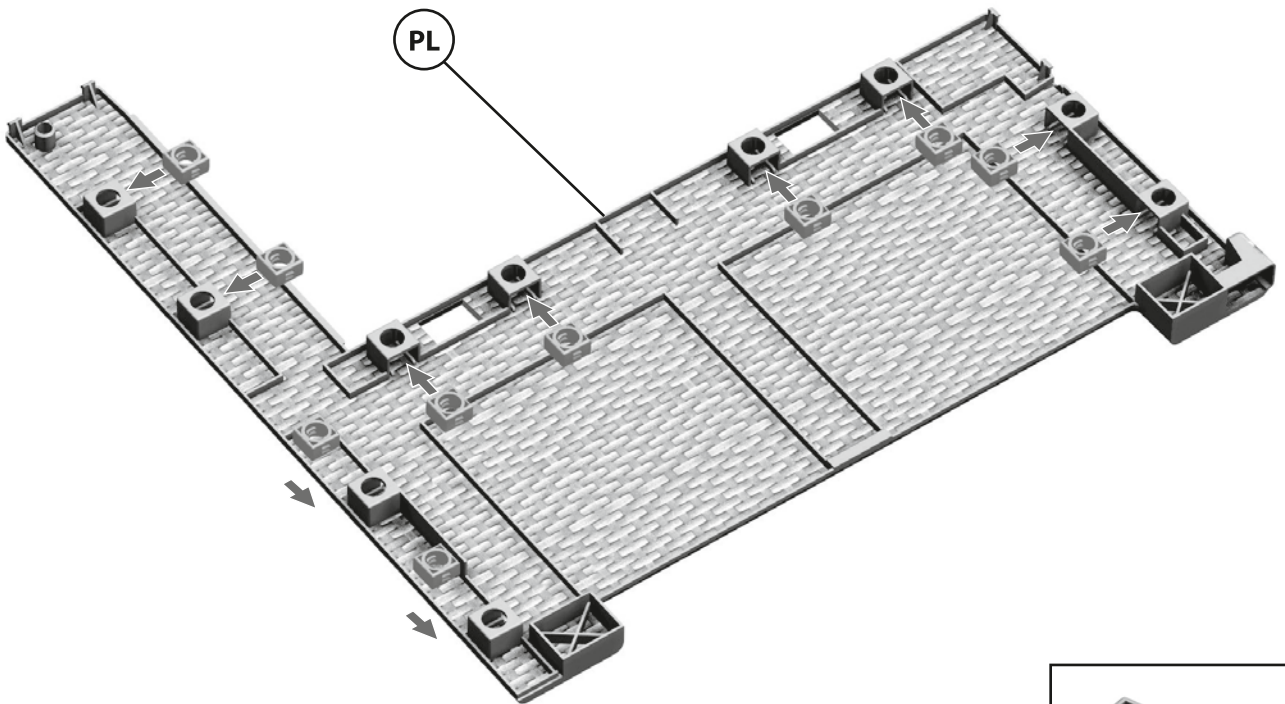

PL

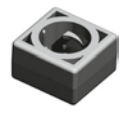

x 10

4

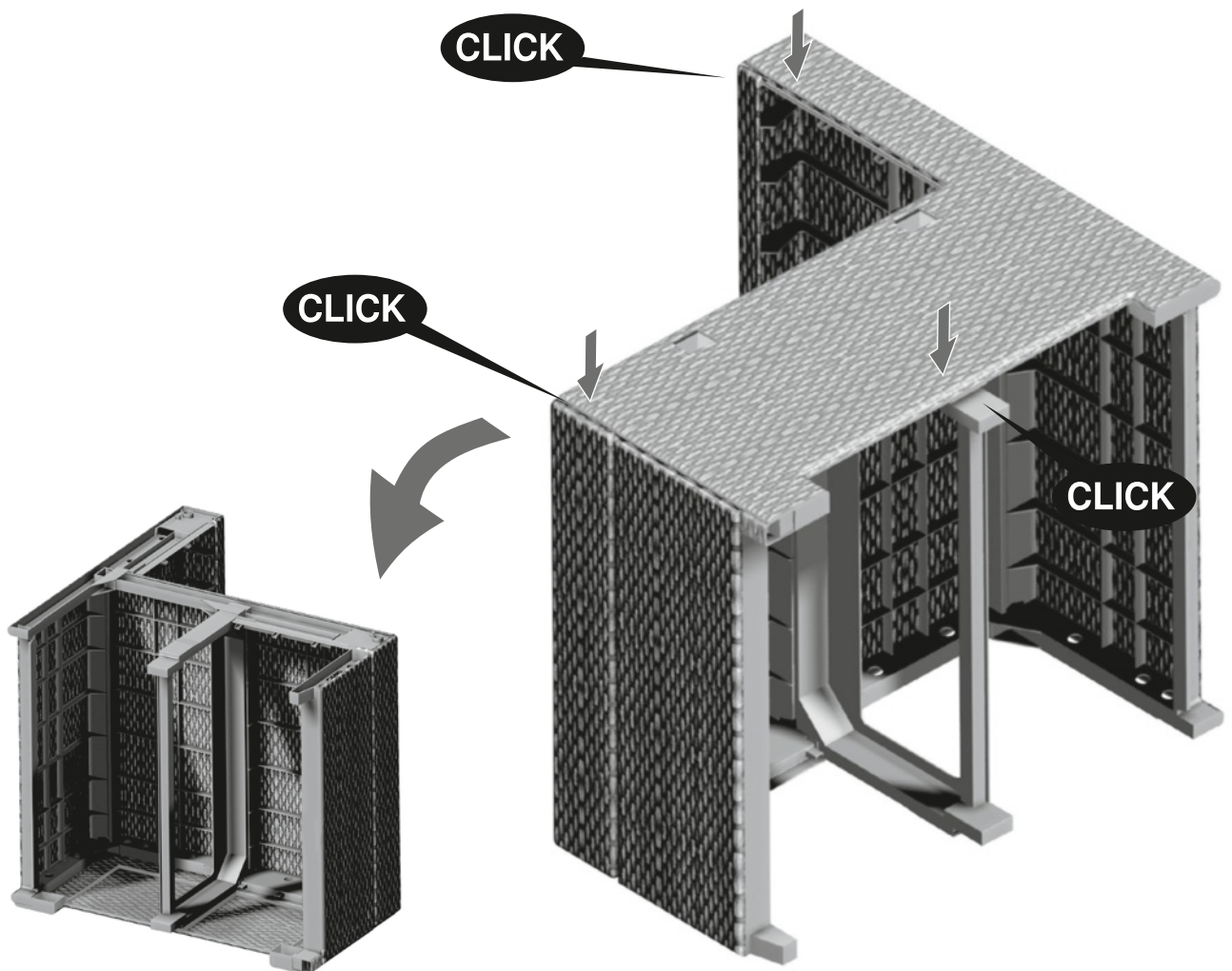
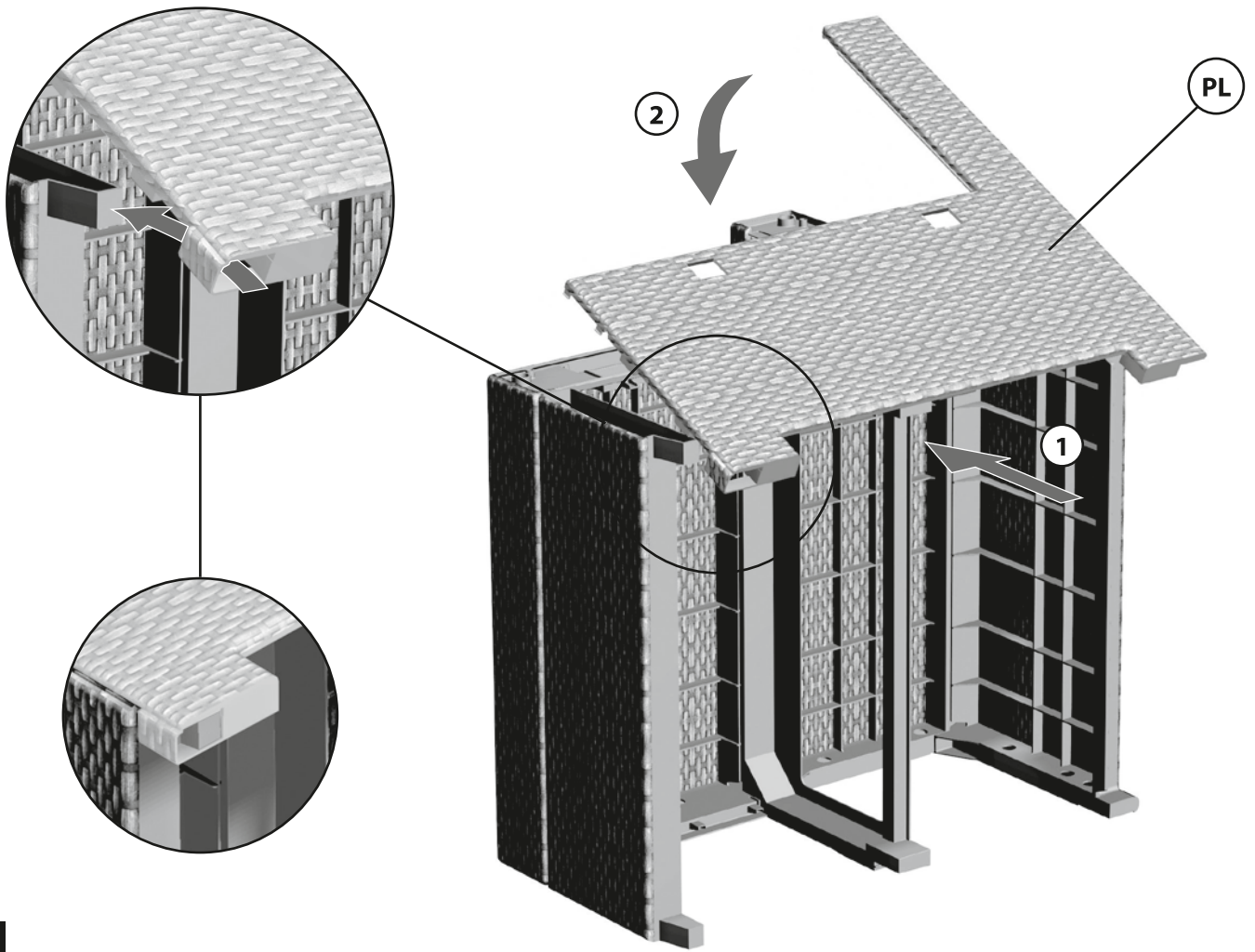

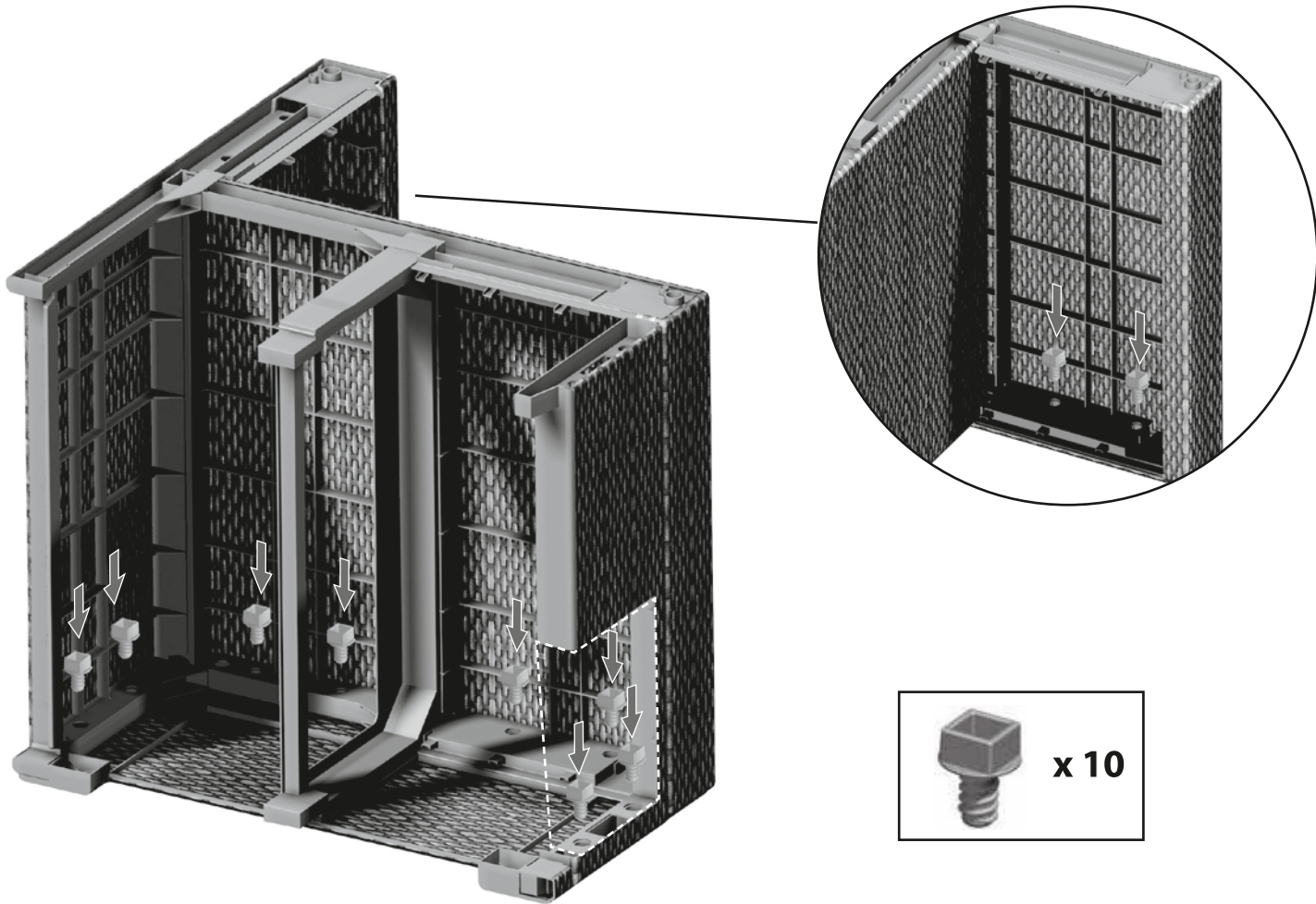

7

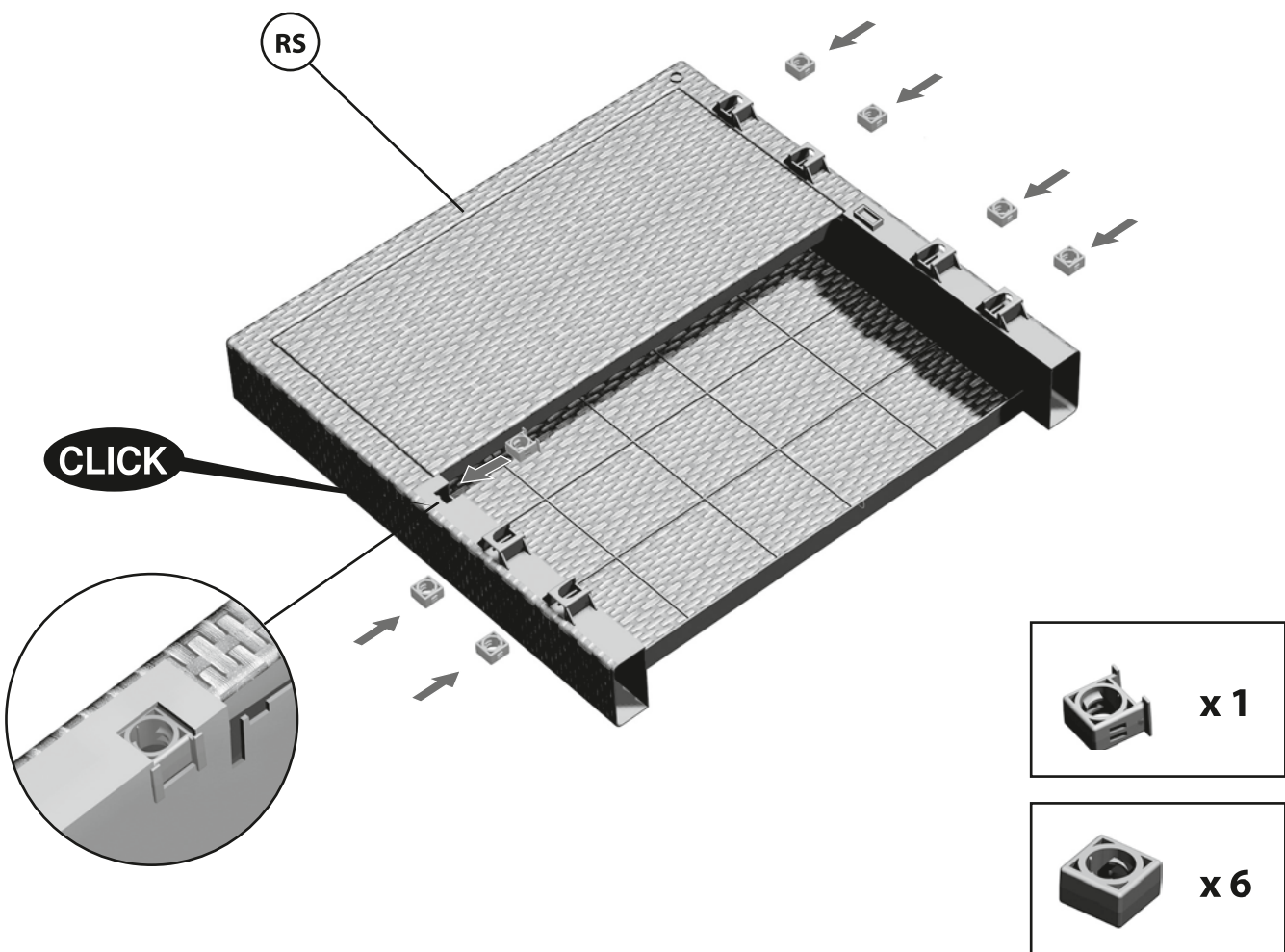

8

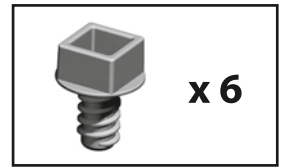
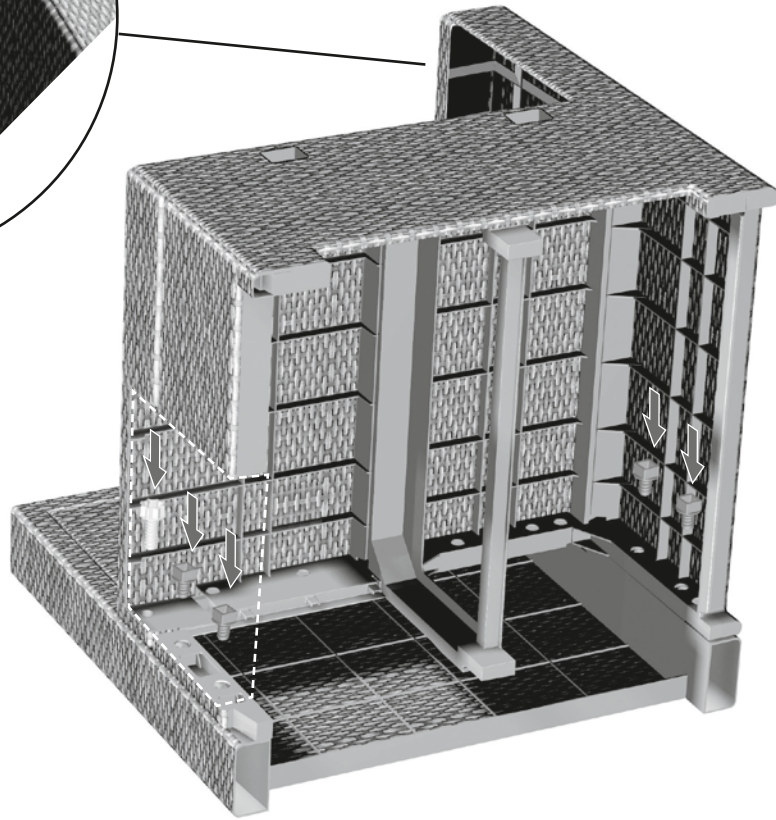
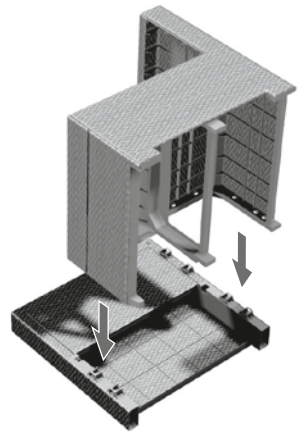
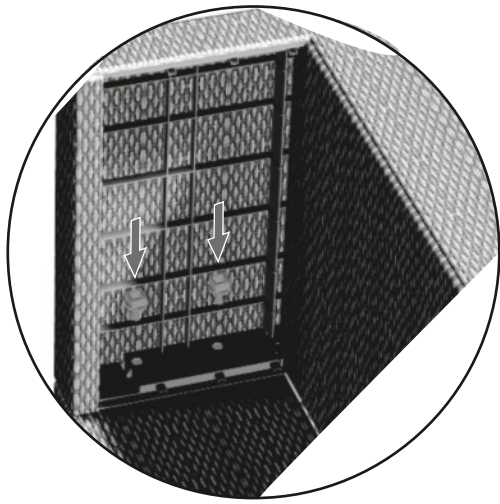

9

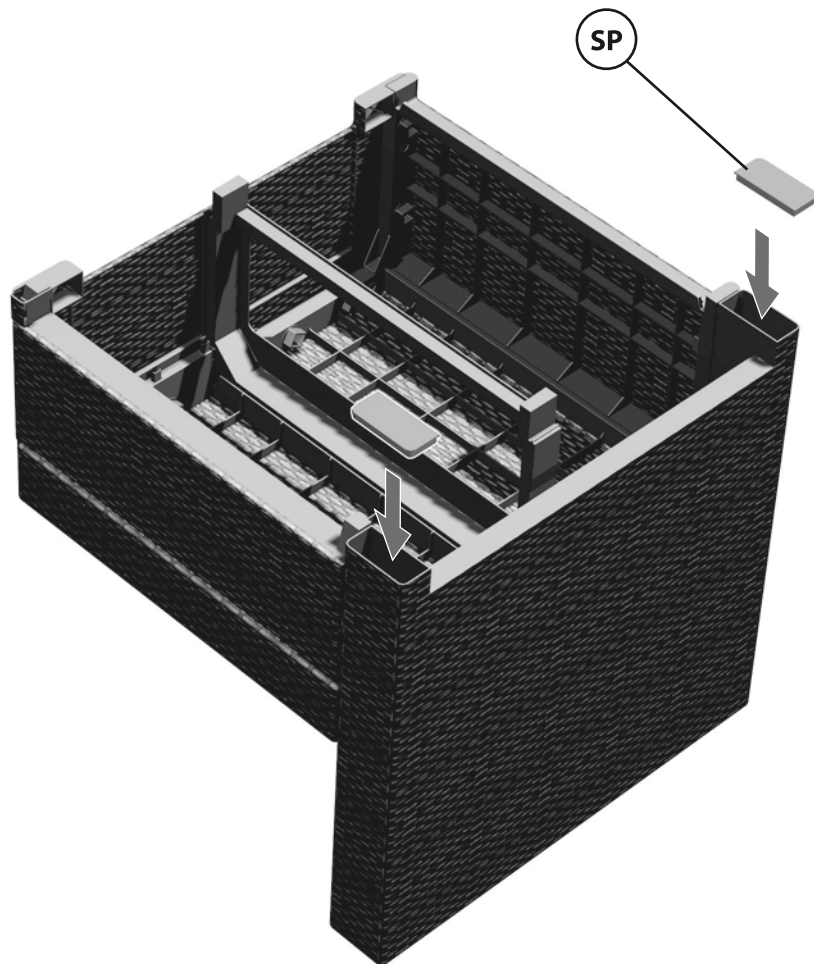
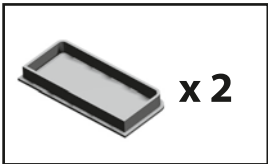

10

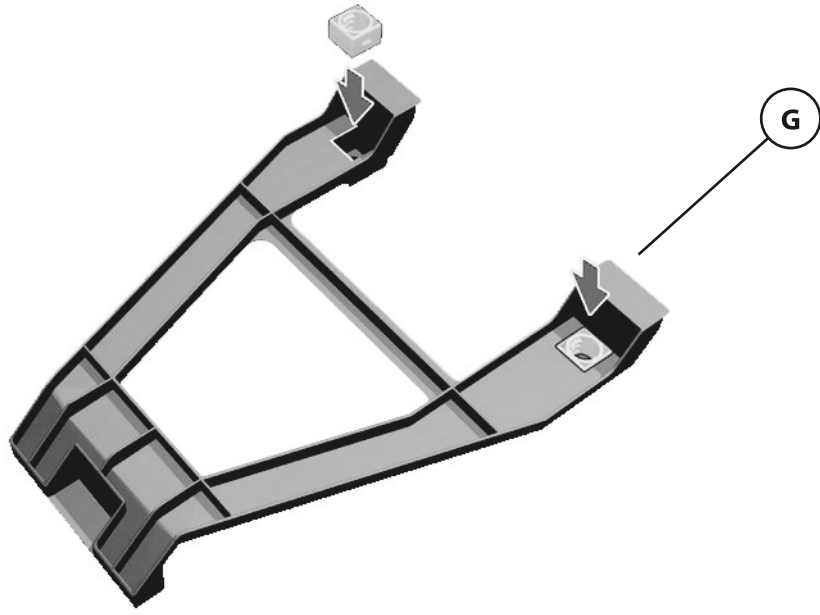
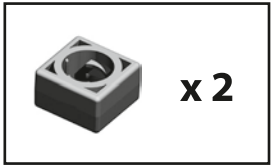

11

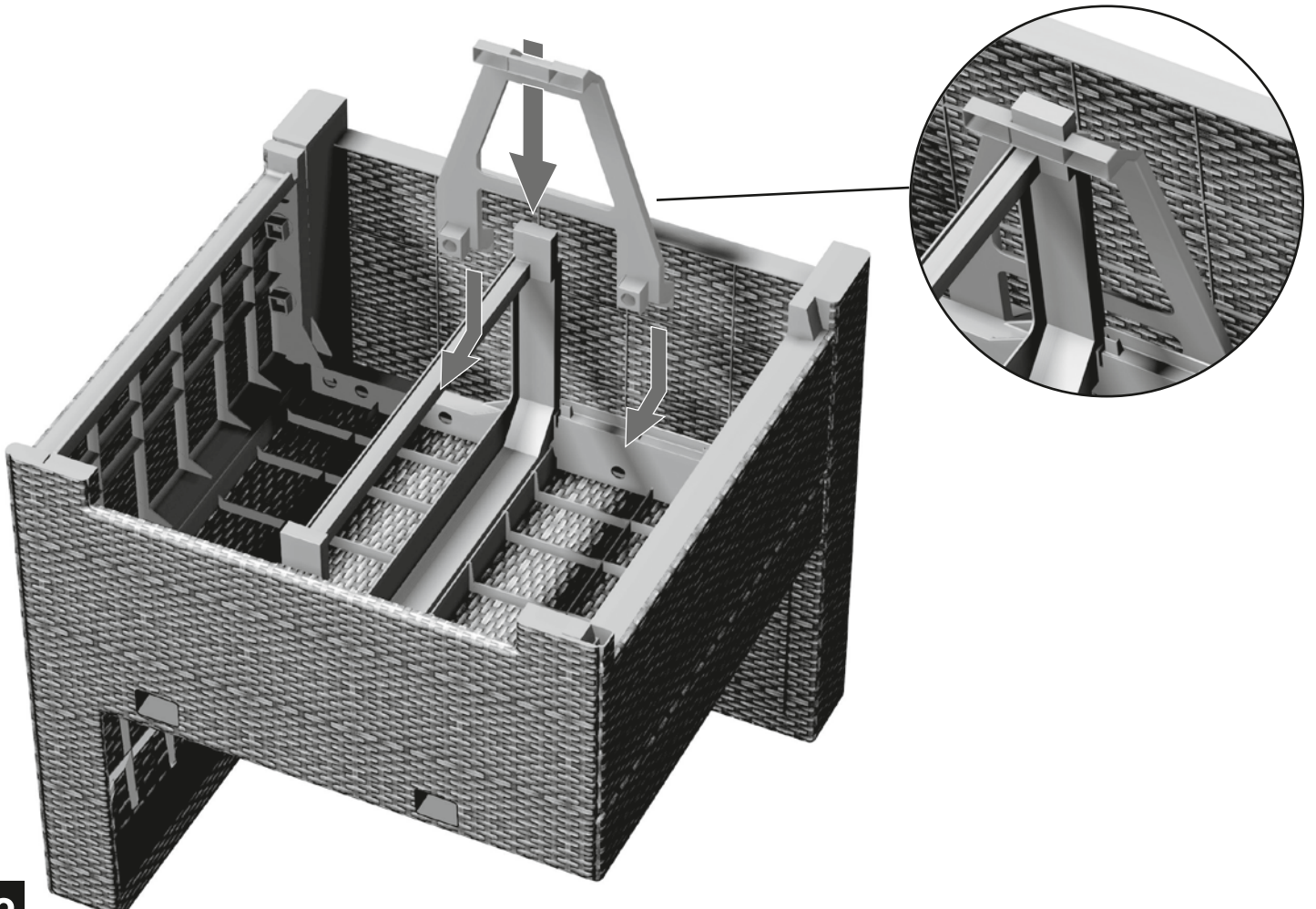

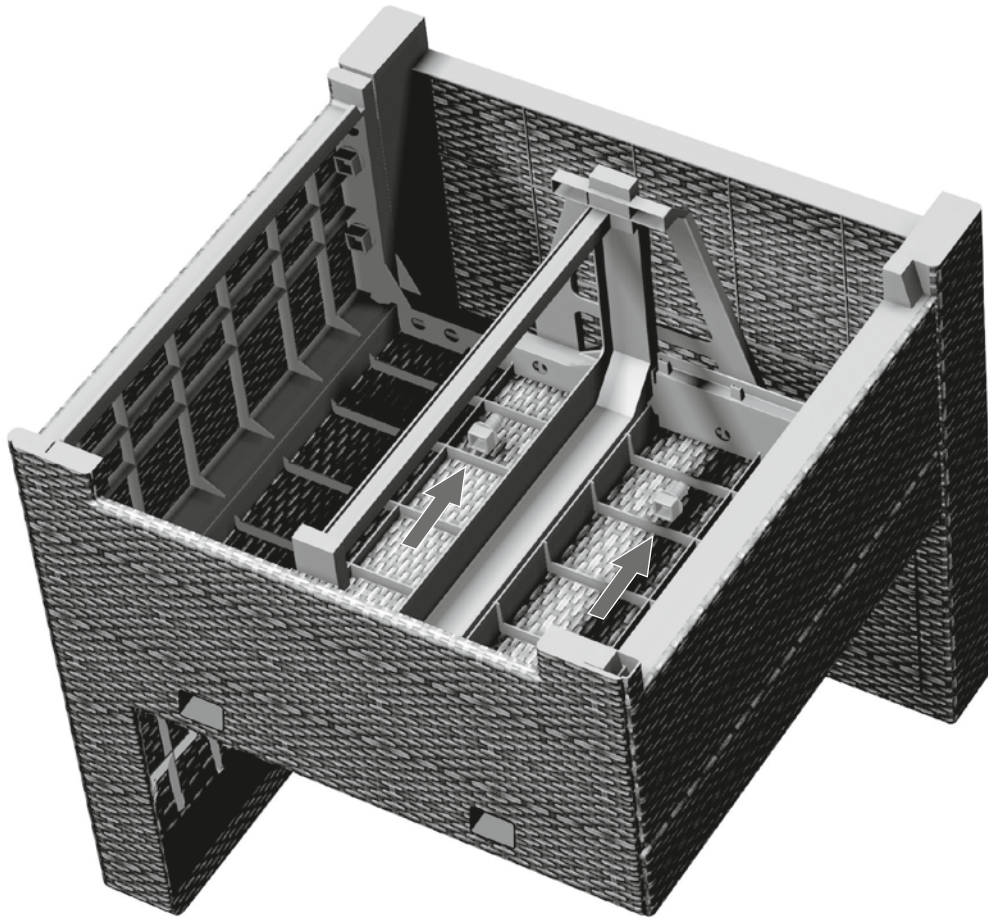
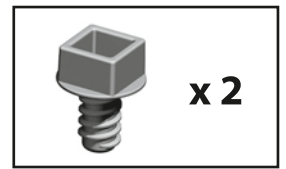

13

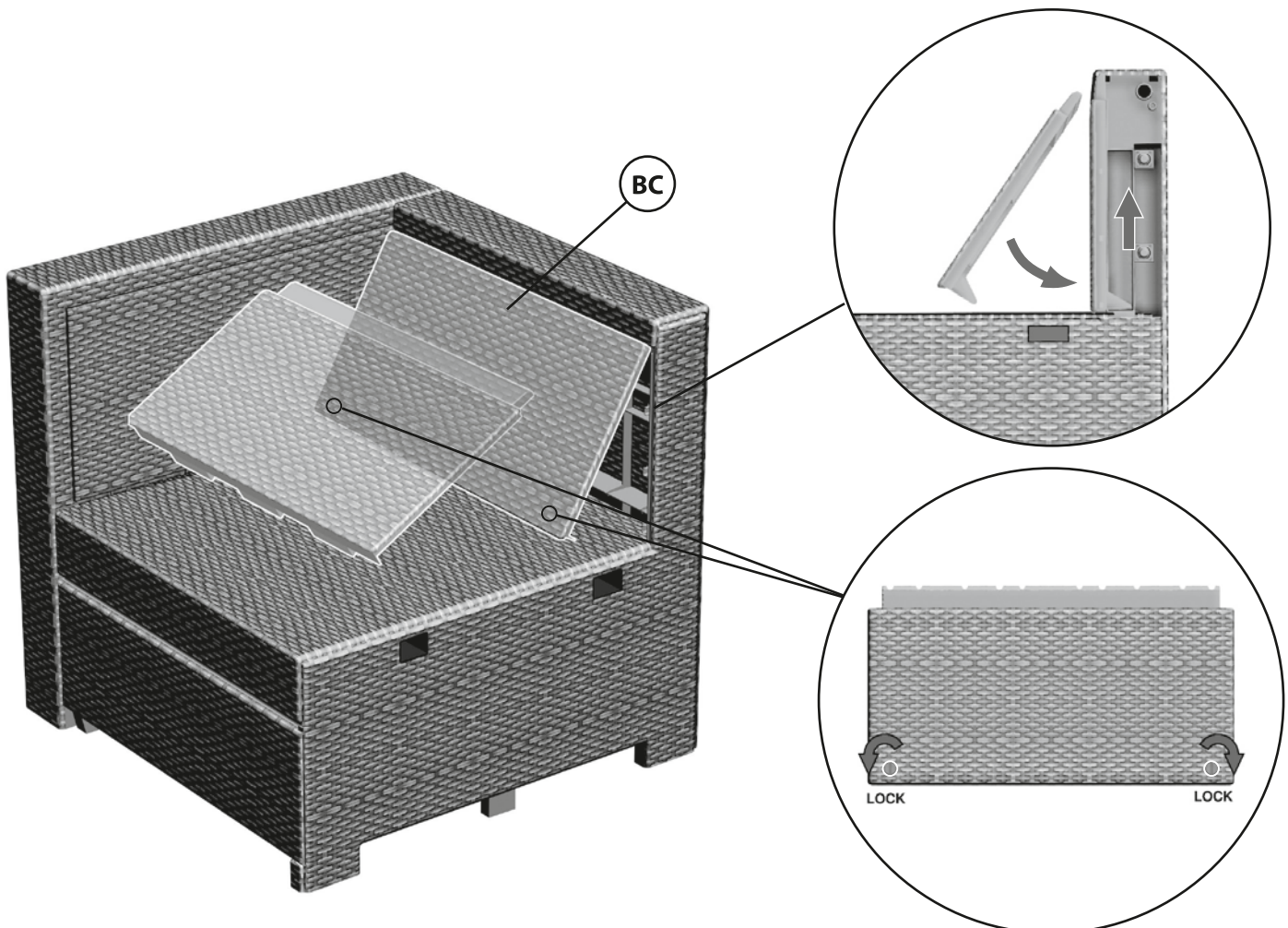

14

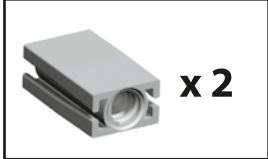
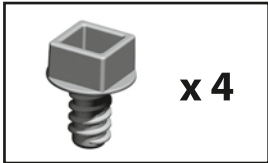

1

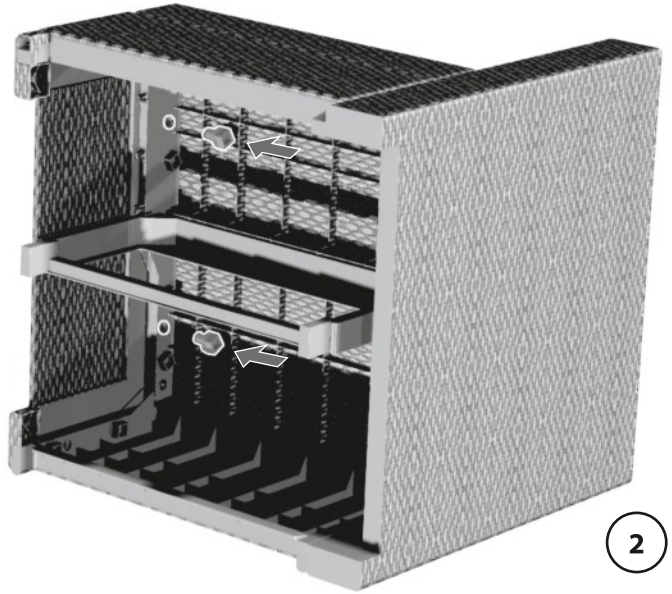
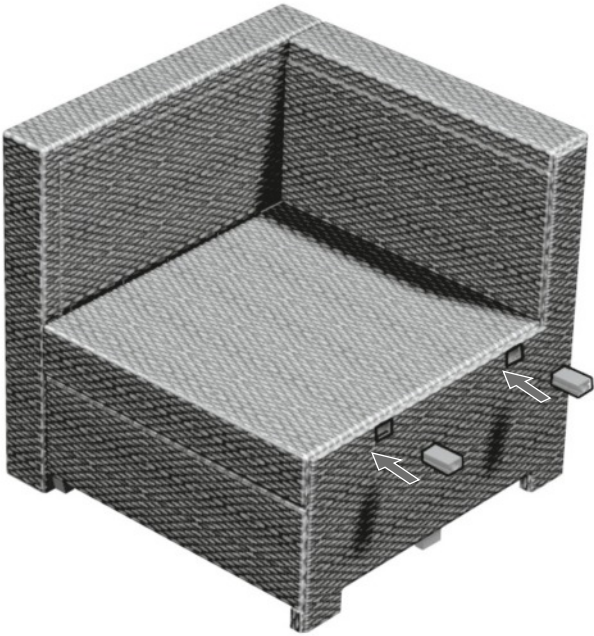

2

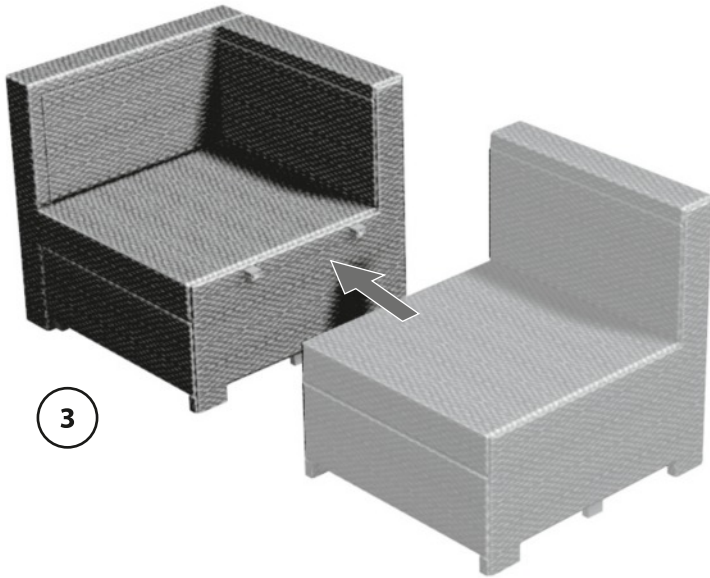

3

4

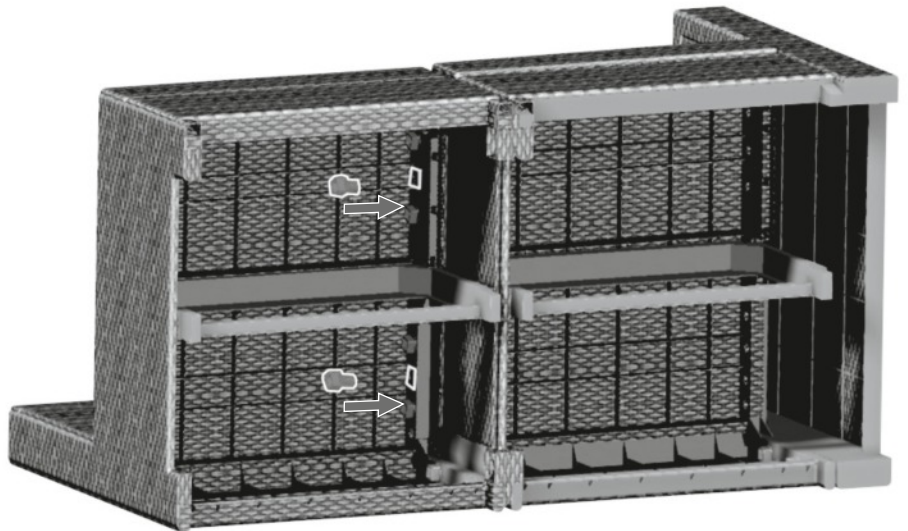

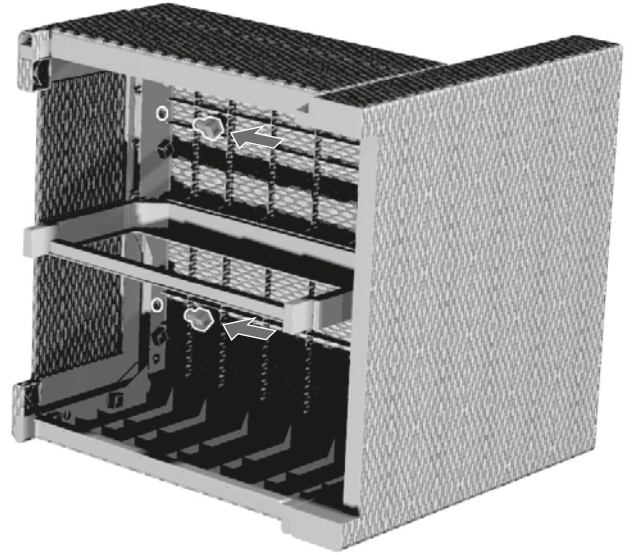
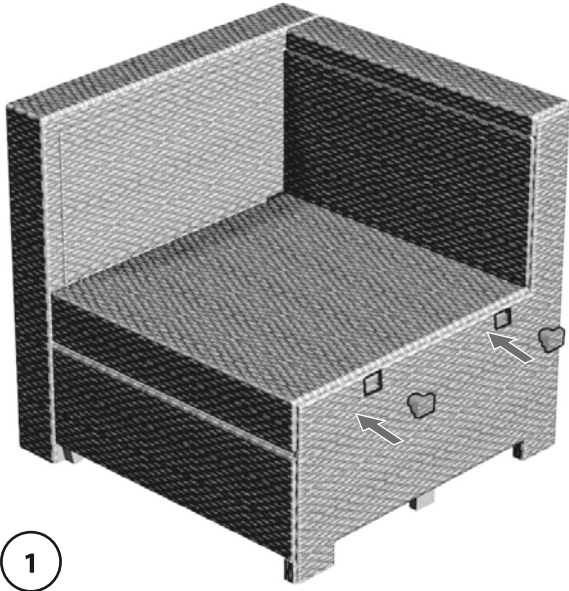

15B

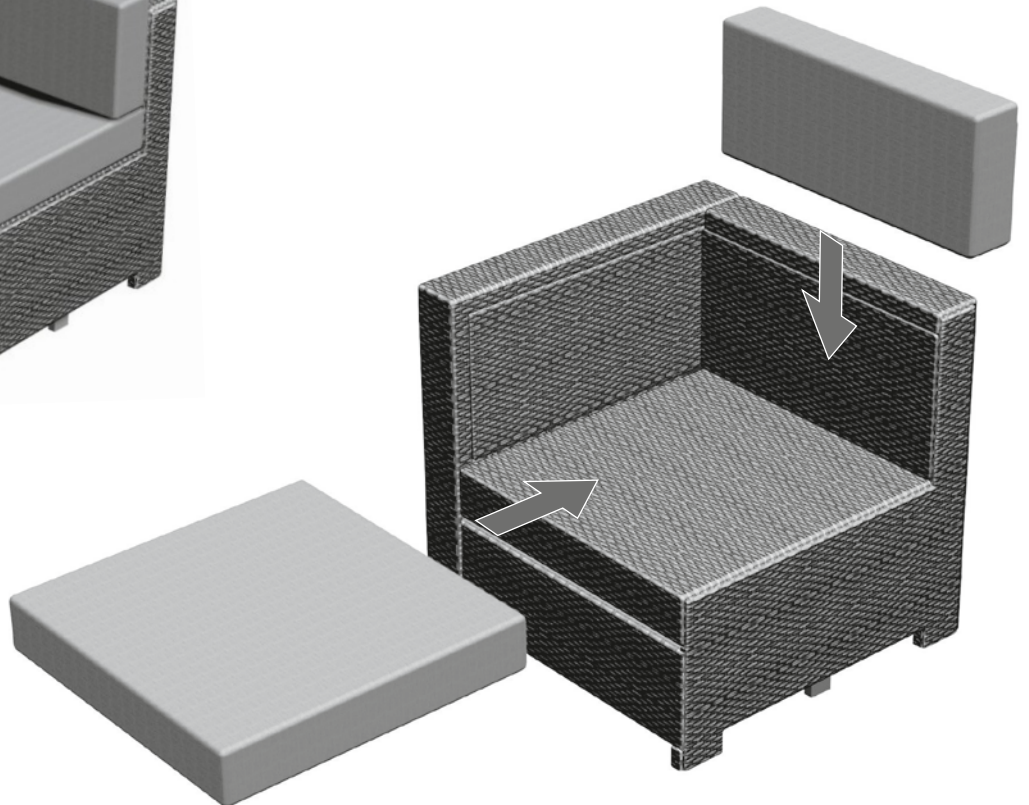

16

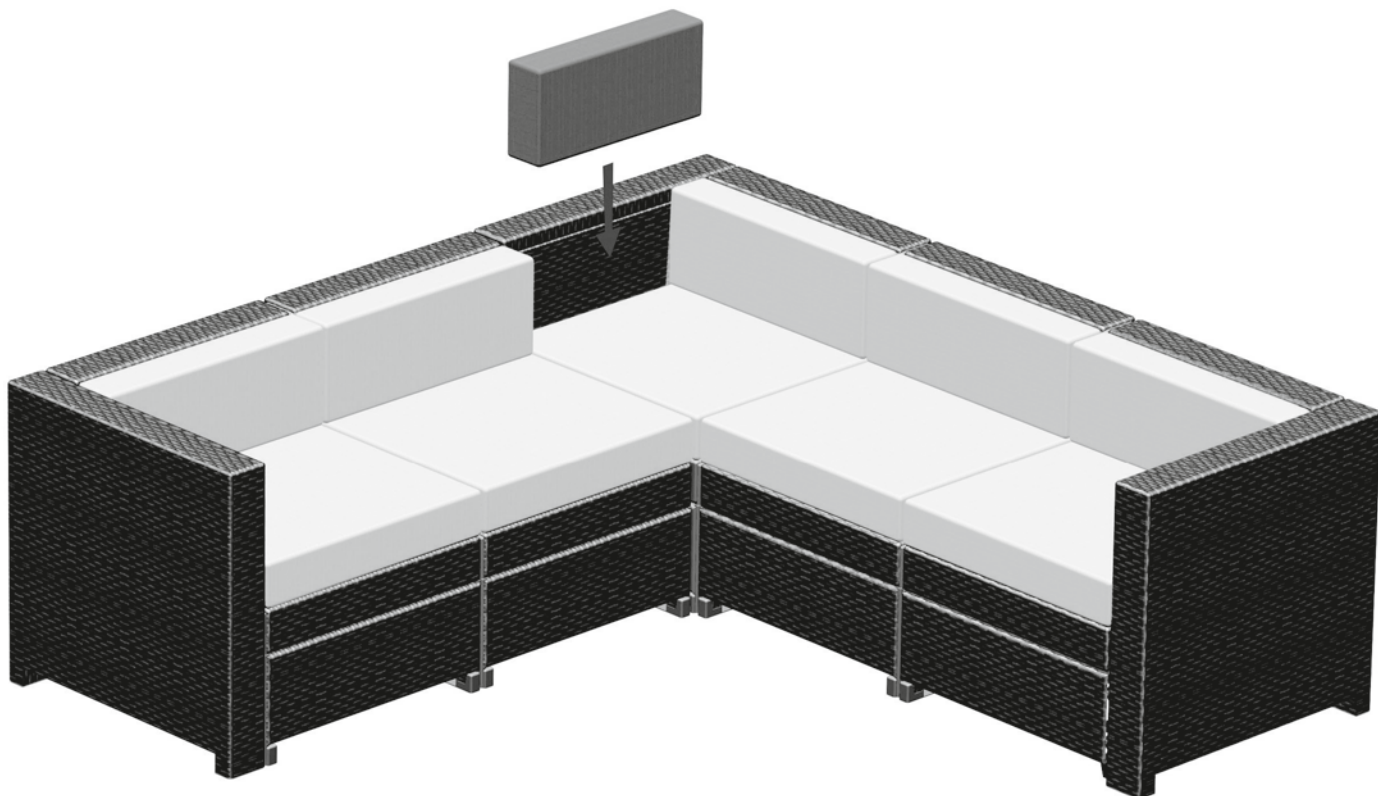

17

PL Na obecnym etapie produkt jest w całości zmontowany.

EN At this stage, the product is completely assembled. HU

Jelen szakaszban a termék teljesen összeszerelt.

CZ V této fázi je výrobek úplně zmontovaný.

SK V tejto etape produkt je celkom zmontovaný.

SLO V tem trenutku je izdelek popolnoma sestavljen.

RO În faza prezentă produsul este complet asamblat.

HR U ovoj fazi proizvod je potpuno montiran.

SRB U ovoj fazi proizvod je potpuno montiran.

LT Dabar produktas visiškai surinktas.

LV Tagad produkts ir pilnībā salikts.

EST Nüüd on toode täielikult kokku pandud.

UA В даному етапі продукція повністю розібрана.

RU В данном этапе продукция полностью разобрана.

